

Left Main Disease

Comparisons of PCI against CABG

10 years of advances

	Design	N (PCI/ CABG)	Endpoint	FU, yrs	Key findings
MAIN COMPARE (2008, 2010, 2018)	Multicenter registry	1102/1138	Death; death, Q-wave MI, or stroke; TVR	10	Similar rates of mortality and death, Q-wave MI, or stroke; higher rates of TVR with PCI
LE MANS (2008, 2016)	Multicenter RCT	52/53	Change in LVEF	10	Improvement in ejection fraction only with PCI, comparable rates of death, MI, stroke, or TVR
SYNTAX (2010, 2014)	Multicenter RCT	357/348	Death, MI, stroke, or RR	5	Comparable rates of death, MI, stroke, or repeat revascularization
Boudriot et al. (2011)	Multicenter RCT	100/101	Death, MI, or RR	1	PCI with sirolimus-eluting stent inferior to CABG
PRECOMBAT (2011, 2015, 2020)	Multicenter RCT	300/300	Death, MI, stroke, or ischemia-driven TVR	10	PCI non-inferior to CABG at 1, 5, and 10 year, comparable rates of death, MI, stroke, or ischemia-driven TVR
DELTA (2012)	Multicenter registry	1874/901	Death, MI, or stroke	3.5	Comparable rates of death, MI, or stroke. Higher TVR in PCI
NOBLE (2016)	Multicenter RCT	592/592	Death, MI, stroke, or any repeat revascularization	5	CABG superior to PCI (primary end points 28% in PCI group vs in 18% in CABG group)
EXCEL (2016, 2018)	Multicenter RCT	948/957	Death, MI, or stroke	4	Similar rates of primary endpoint of death, stroke, or MI at 4 years

TABLE 1 Summary of Randomized Clinical Trials of PCI With DES Vs CABG for LMCA Disease

	LEMANS^{30,31}	Boudriot et al³²	SYNTAX-LM³³⁻³⁵	PRECOMBAT^{36,38}	EXCEL^{39,40}	NOBLE^{41,42}
Recruitment period	2001-2004	2003-2009	2005-2007	2004-2009	2010-2014	2008-2015
PCI/CABG, n/n	52/53	100/101	357/348	300/300	948/957	592/592
Follow-up, y	10	1	5 10 (for mortality)	10	5	5
Diabetes, %	18	36	25	32	29	15
Bifurcation, %	58	72	61	64	81	81
SYNTAX score, mean	Not reported	23	30	25	21	22
Stent	BMS and DES (35%)	DP-SES	DP-PES	DP-SES	DP-EES	BP-BES and DP-SES (7.7%)
IVUS	Recommend	Infrequent	Infrequent	At discretion, 91%	Recommended, 77%	Recommended, 74%
FFR guidance	Not reported	Not reported	Infrequent	Not reported	Recommended, 9.0%	Recommended
LIMA, %	72	99	97	94	99	96
Off pump, %	1.9	46	Not reported	64	29	16
Primary trial endpoint	Change in LVEF	Cardiac death, MI, or TVR	Death, MI, stroke, or repeat revascularization 10-y all-cause death	Death, MI, stroke, or TVR	Death, MI, or stroke	Death, nonprocedural MI, stroke, or repeat revascularization
Key finding	There was a trend toward higher LVEF at 10 y with PCI.	PCI was inferior to CABG at 1 y.	PCI was noninferior to CABG at 1 and 5 y in terms of death, MI, stroke, or repeat revascularization. No significant difference in 10-y all-cause death between PCI and CABG.	PCI was noninferior to CABG at 1, 5, and 10 y.	PCI was noninferior to CABG at 3 and 5 y.	PCI was inferior to CABG at 5 y.

Data for Left Main

30 years ago

CABG vs. Medical Rx
(150 pts, VA and EU RCT)

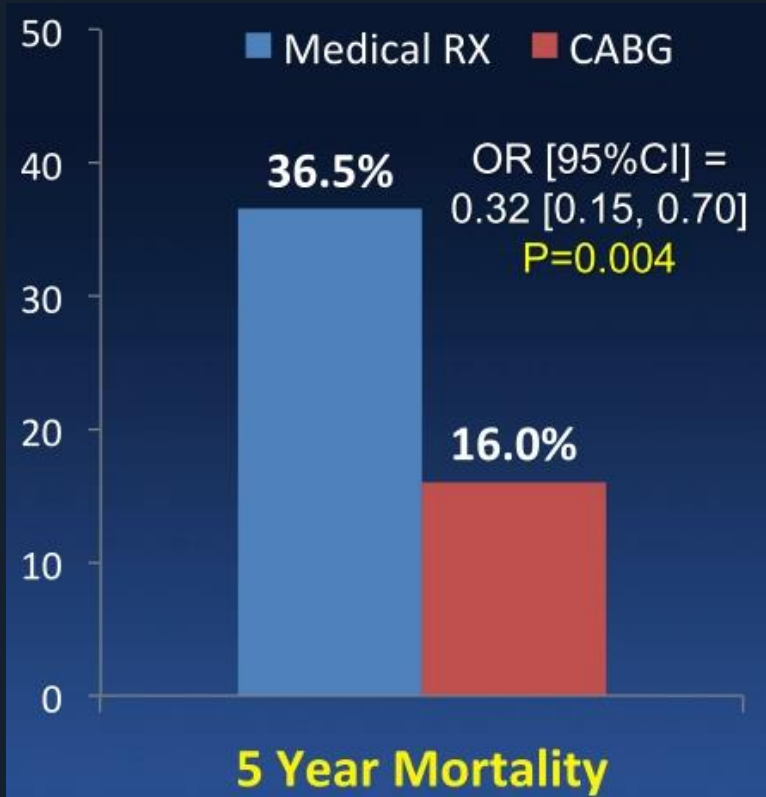

Yusuf S et al. Lancet 1994; 344: 563-70

CABG vs. Medical Rx
(1484 pts, CASS Registry)

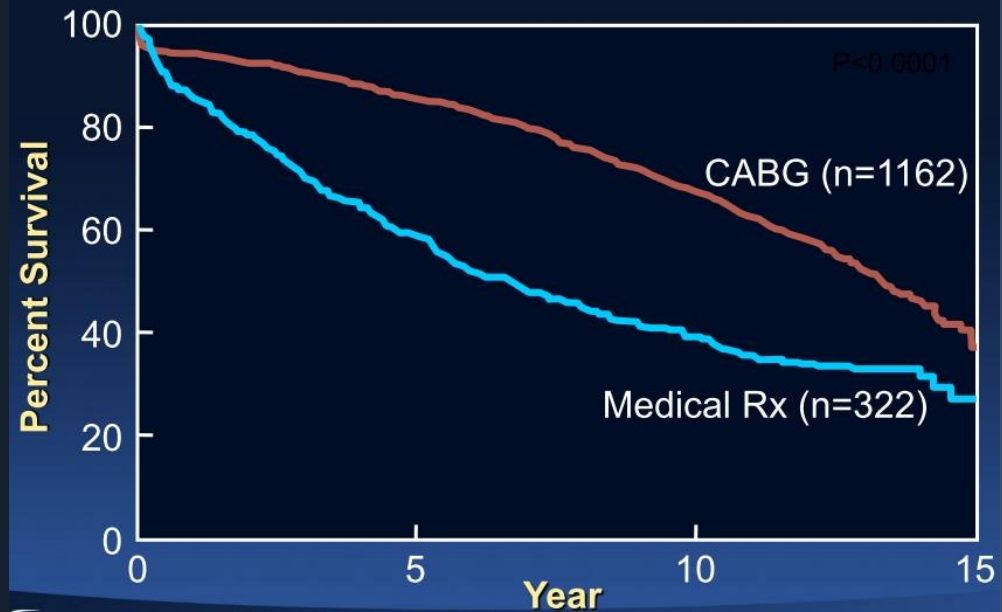

Yusuf S et al. Lancet 1994; 344: 563-70

PTCA was not considered as an Tx option

Guideline Changes for LMCA, 10 Years

	Class of recommendation	LOE
2005 ACC/AHA/SCAI	III —PCI is not recommended in patients with unprotected LMCA disease and eligibility for CABG	C
2005 ESC/EACTS	Ib —Stenting for unprotected LMCA disease should only be considered in the absence of other revascularization options	C
2011/2014 ACC/AHA/AATS/PCNA/SCAI/STS	Ia —For SIHD patients when both of the following are present: <ul style="list-style-type: none"> Anatomically low risk of PCI procedural complications & high likelihood of good long-term outcomes (e.g., a low SYNTAX score [≤ 22], ostial or trunk left main stenosis) Clinical characteristics that predict a significantly increased risk of adverse surgical outcomes (e.g., STS-predicted risk of operative mortality $\geq 5\%$)	B
	Ib —For SIHD patients when both of the following are present: <ul style="list-style-type: none"> Anatomically low-to-intermediate risk of PCI procedural complications & intermediate-to-high likelihood of good long-term outcome (e.g., low-intermediate SYNTAX score of < 33, bifurcation left main stenosis) Clinically increased risk of adverse surgical outcomes 	B
	III: HARM —SIHD patients with unfavorable anatomy for PCI & good candidates for CABG	B
2014 ESC/EACTS	I —Left main disease with a SYNTAX score ≤ 22 .	B
	Ib —Left main disease with a SYNTAX score 23–32	
	III —Left main disease with a SYNTAX score ≥ 33	
2018 ESC/EACTS	I —Left main disease with a SYNTAX score ≤ 22 .	A
	Ia —Left main disease with a SYNTAX score 23–32	B
	III —Left main disease with a SYNTAX score ≥ 33	
2021 ACC/AHA	I —In patients with SIHD and significant left main stenosis, CABG is recommended to improve survival.	B
	Ia —In selected patients with SIHD and significant left main stenosis for whom PCI can provide equivalent revascularization to that possible with CABG, PCI is reasonable to improve survival	B

Elective PCI for LM Stenosis

ESC/EACTS Guidelines 2014

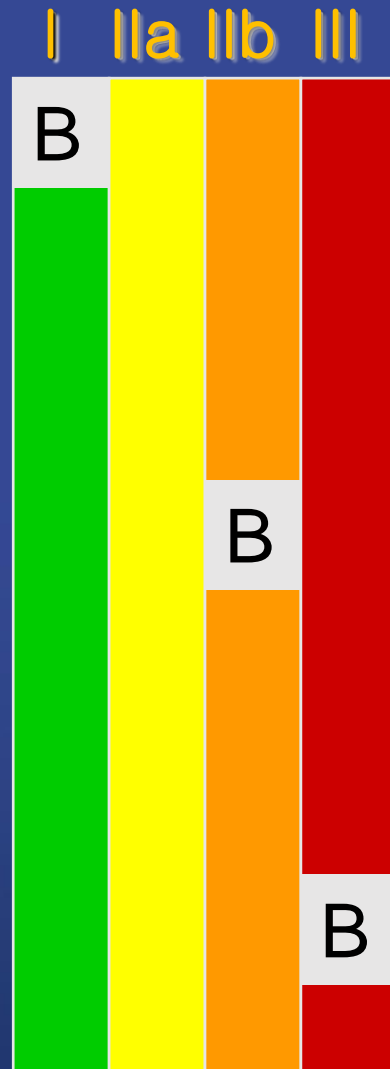

- *LM with*
- SYNTAX score ≤ 22
- *LM with*
- SYNTAX score 23-32
- *LM with*
- SYNTAX score > 32

Elective PCI for LM Stenosis

ESC/EACTS Guidelines 2018

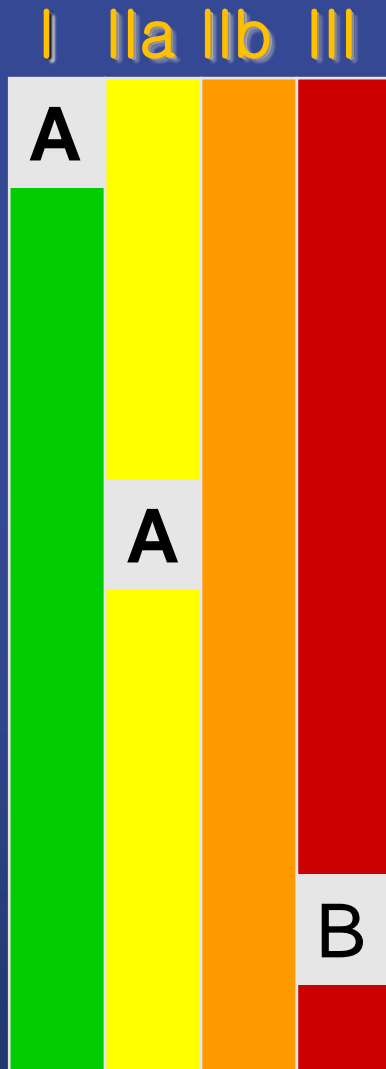

- *LM with*
- SYNTAX score ≤ 22
- *LM with*
- SYNTAX score 23-32
- *LM with*
- SYNTAX score > 32

Elective PCI for LM Stenosis

ACC/AHA Guidelines 2021

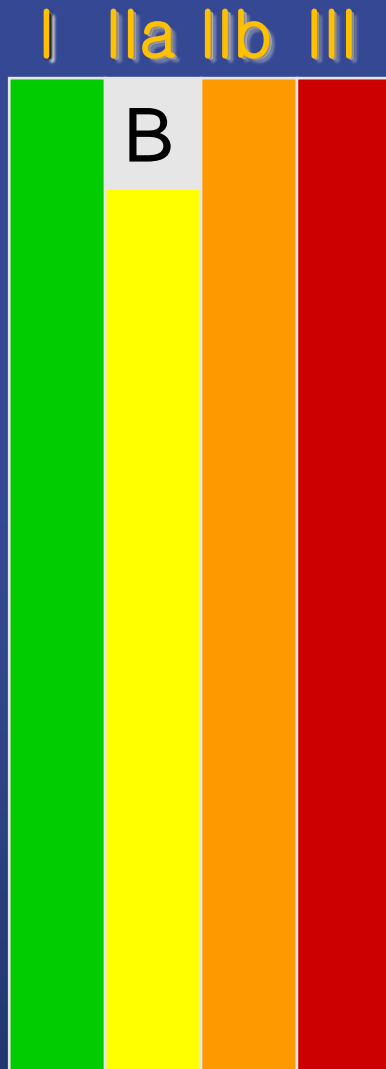

- *PCI and provide equivalent revascularization to that possible with CABG*
- PCI is reasonable to improve survival

LM : PCI vs. CABG

PCI vs. Medical Treatment

Bayesian network meta-analysis involving
12 (PCI vs. CABG), and 7 (CABG vs. Medication) studies

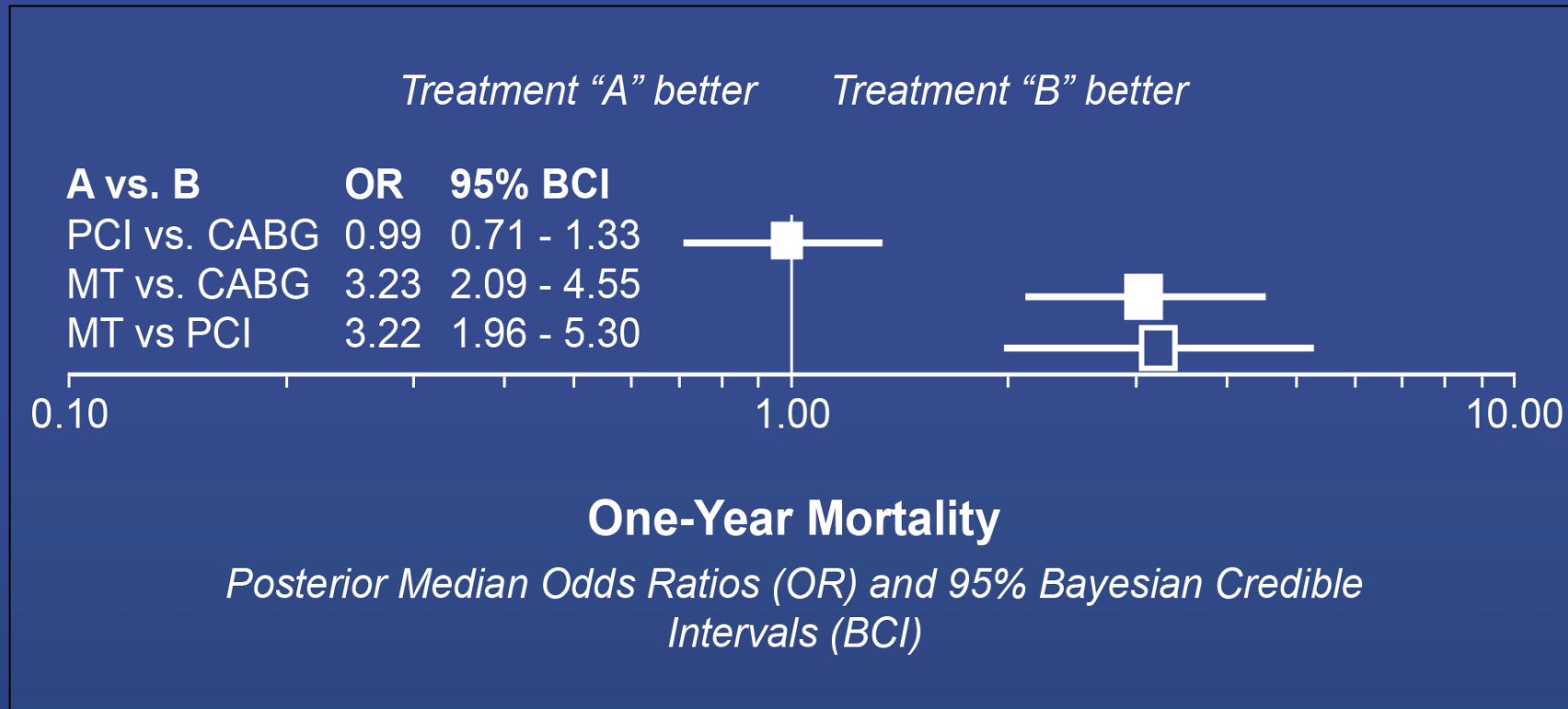

PCI is superior to medical treatment in the treatment of LM stenosis.

Hazard Ratios for Matched Cohort Outcomes : Median 5-Year Outcomes

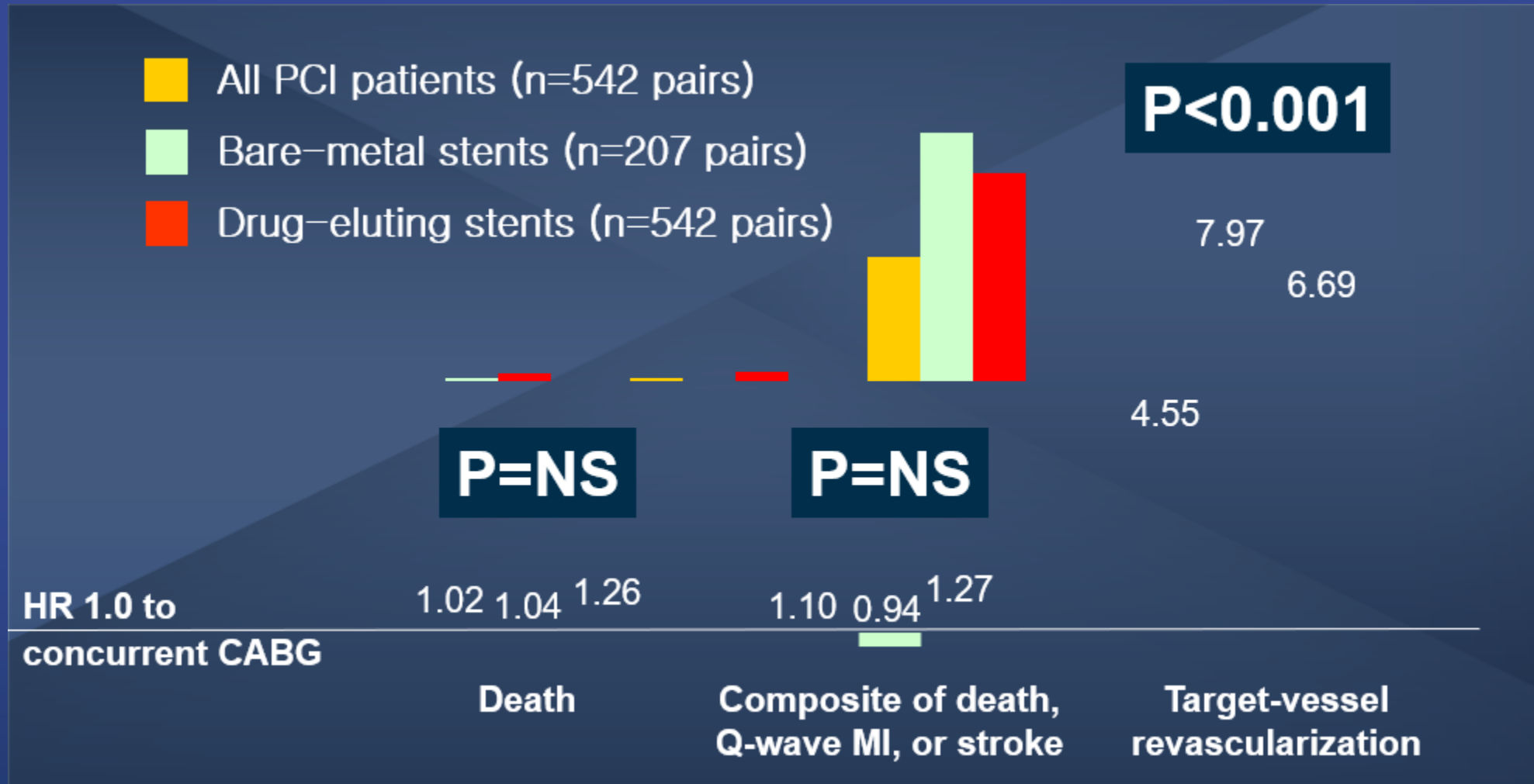

The DELTA Registry

LM revascularization: PCI vs. CABG

Death, MI or CVA in Propensity Score-Matched Groups

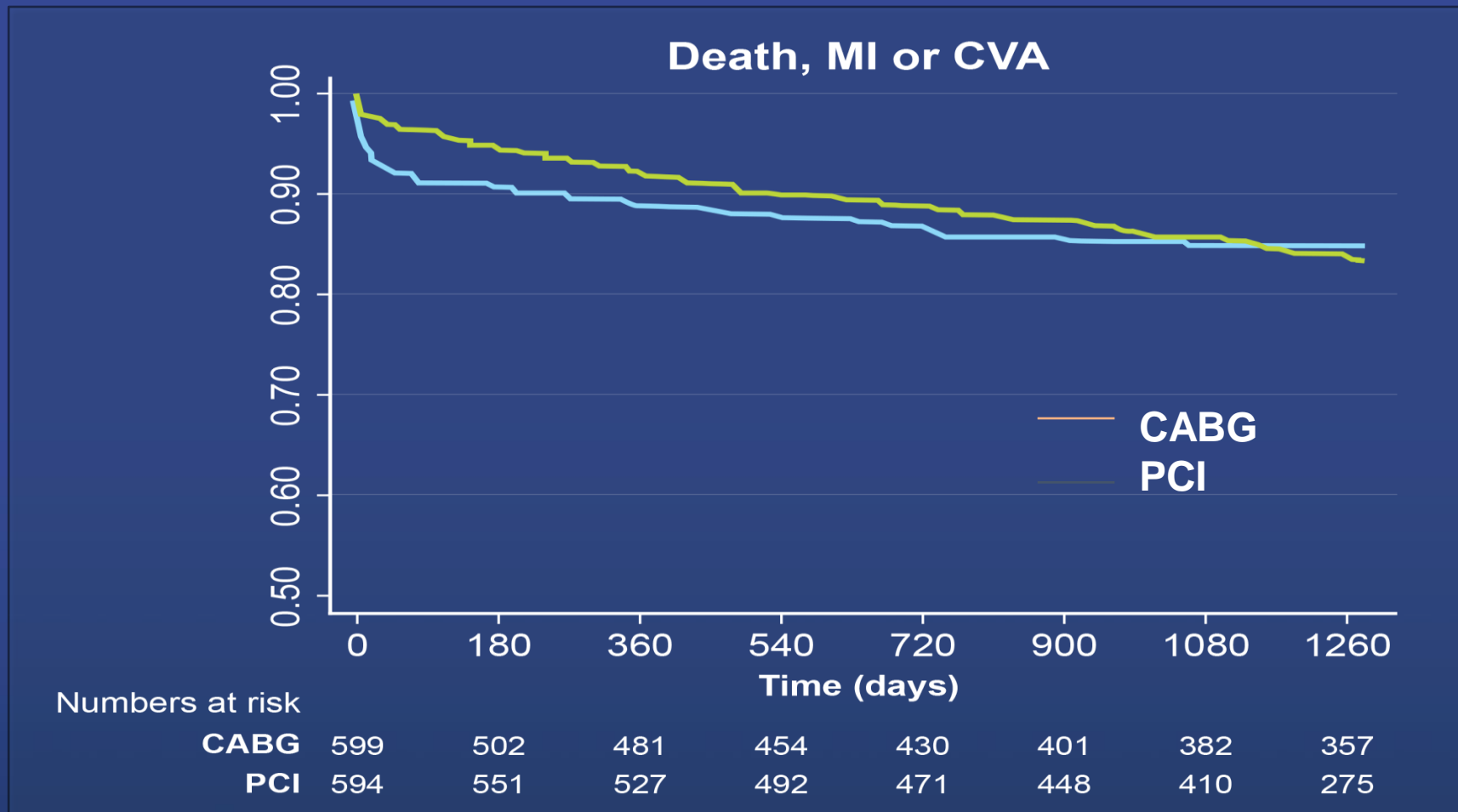

PCI vs. CABG in Females

Female subgroup of *DELTA* registry (PCI, 489; CABG, 328 patients)

The results of propensity score-matched groups

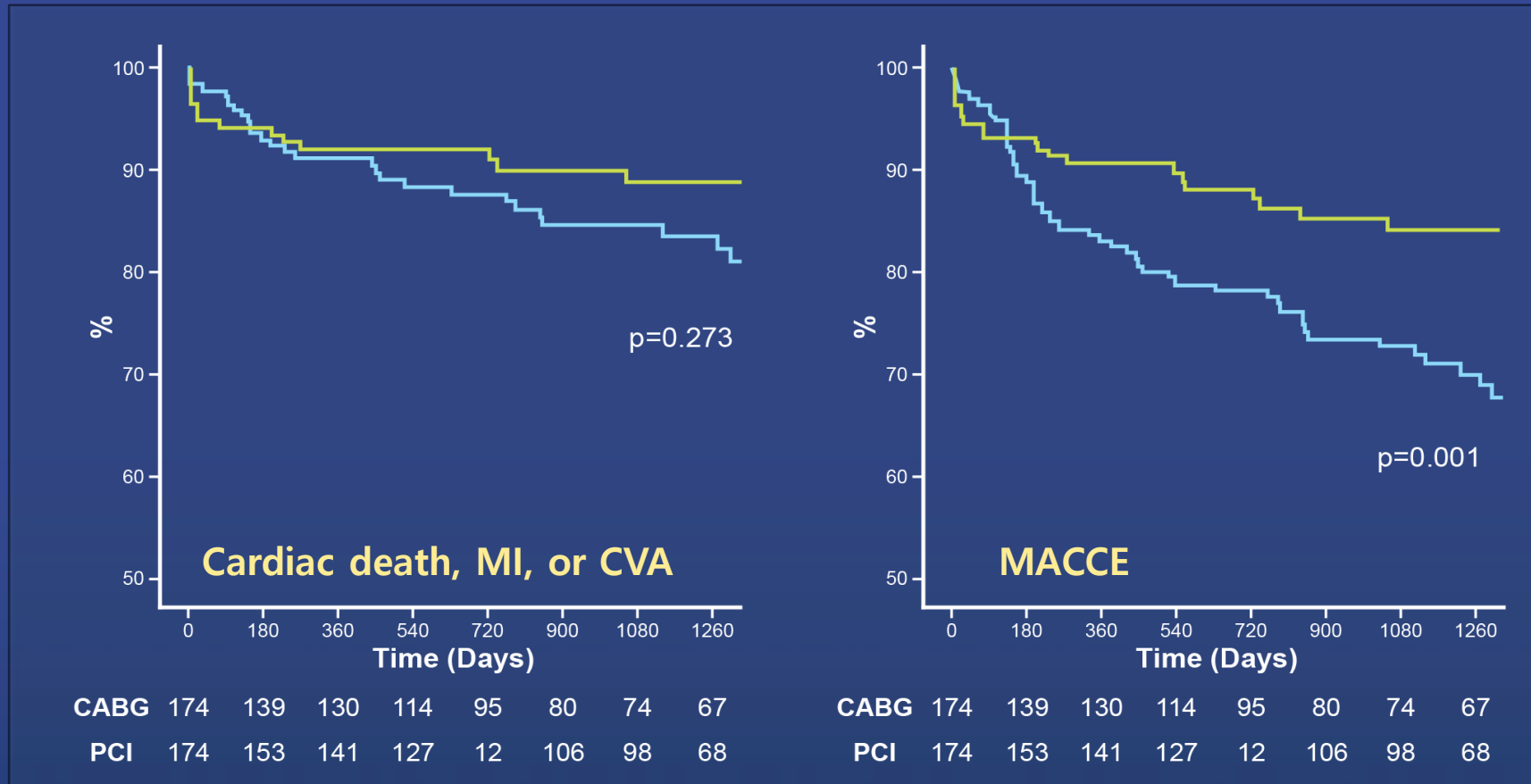

There was no difference in the hard endpoints.

Buchanan et al. *Am J Cardiol*, 2014

PCI vs. CABG in Octogenarians

Octogenarian subgroup of *DELTA* registry (PCI, 218; CABG, 86)

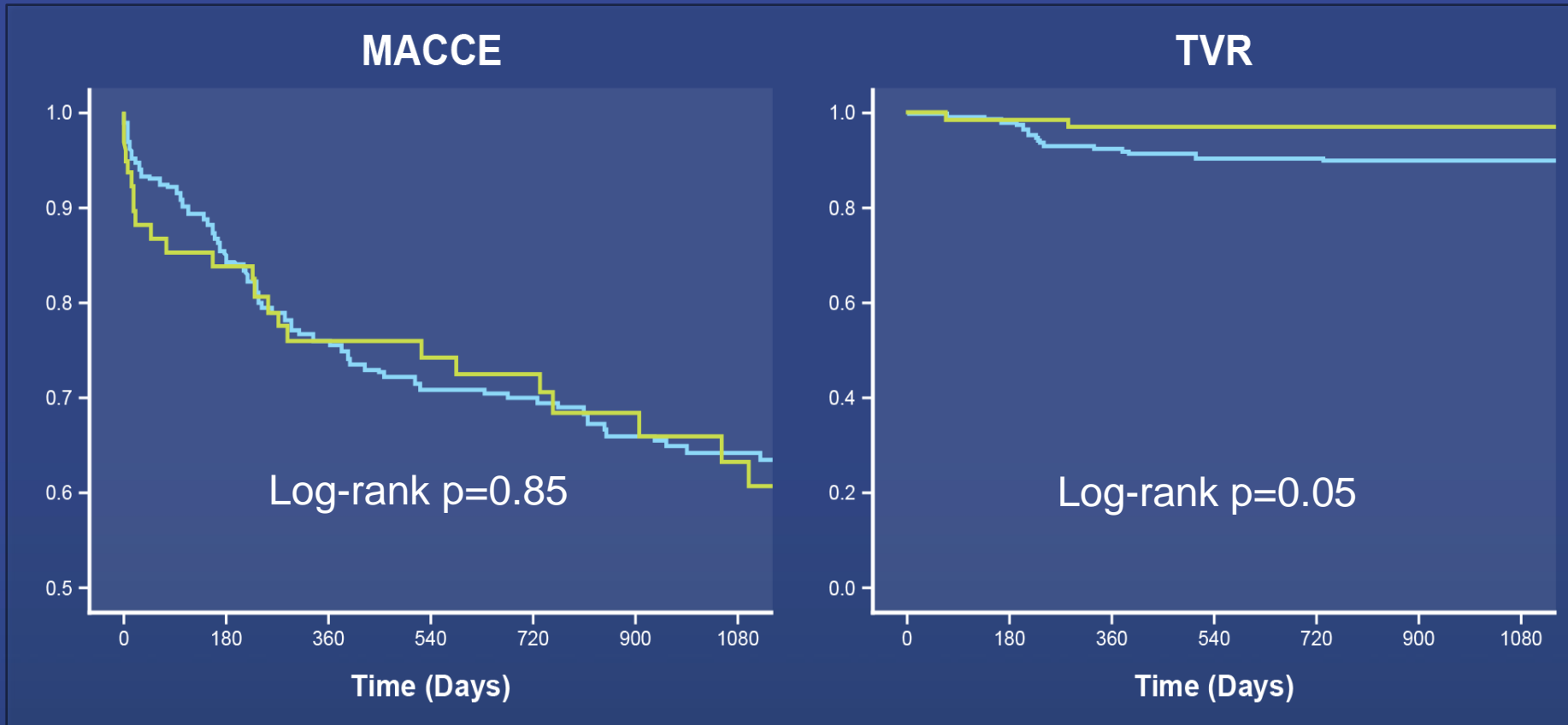

In octogenarians, no difference was observed in the occurrence of the hard endpoint after PCI or CABG.

PCI vs. CABG for Ostial/Midshaft LM stenosis

A subgroup of DELTA registry (PCI, 482; CABG, 374 patients)

The results of propensity score-matched groups

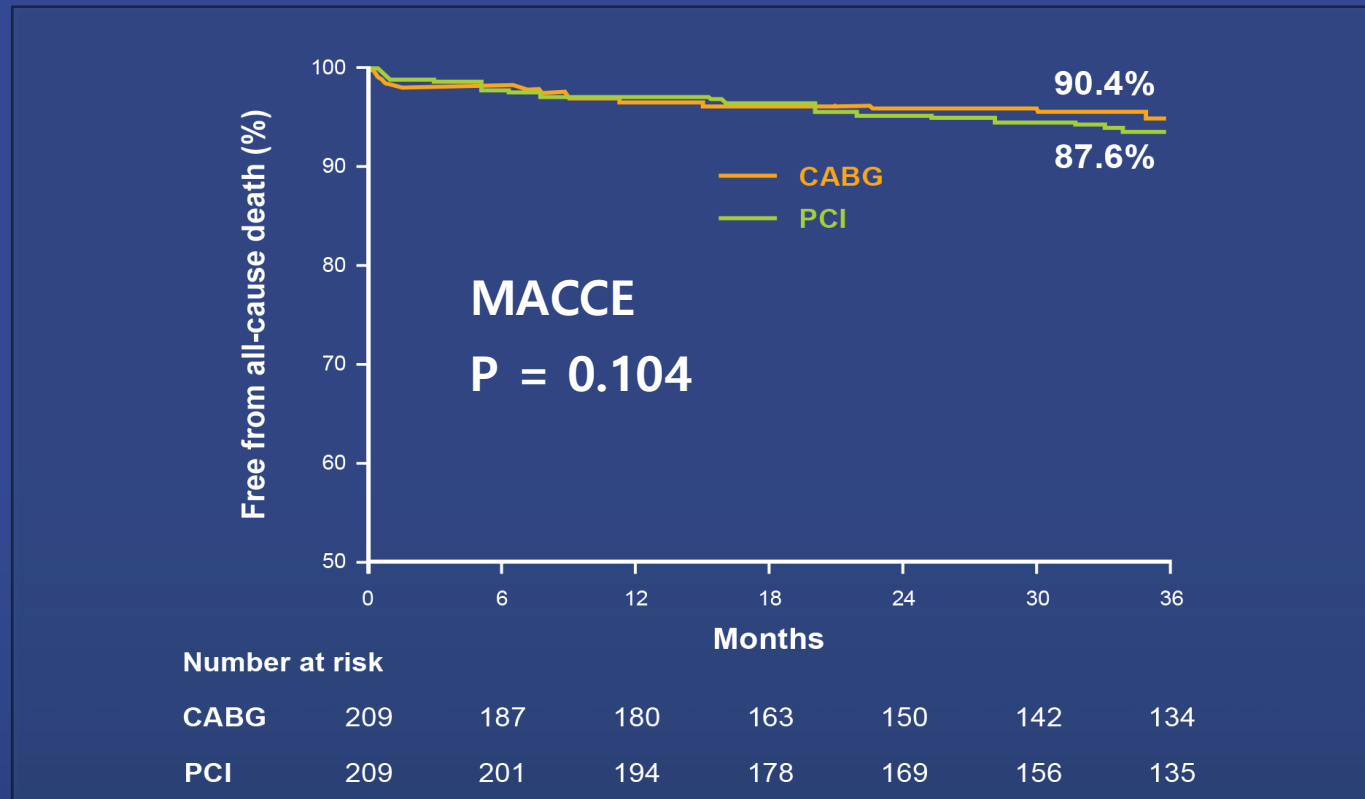

PCI for ostial/midshaft lesions was associated with clinical outcomes comparable to those observed with CABG

Long-term Outcomes of PCI vs. CABG

5-year outcomes of the LM subgroup of the **SYNTAX** trial
:PCI (N=357) vs. CABG (N=348)

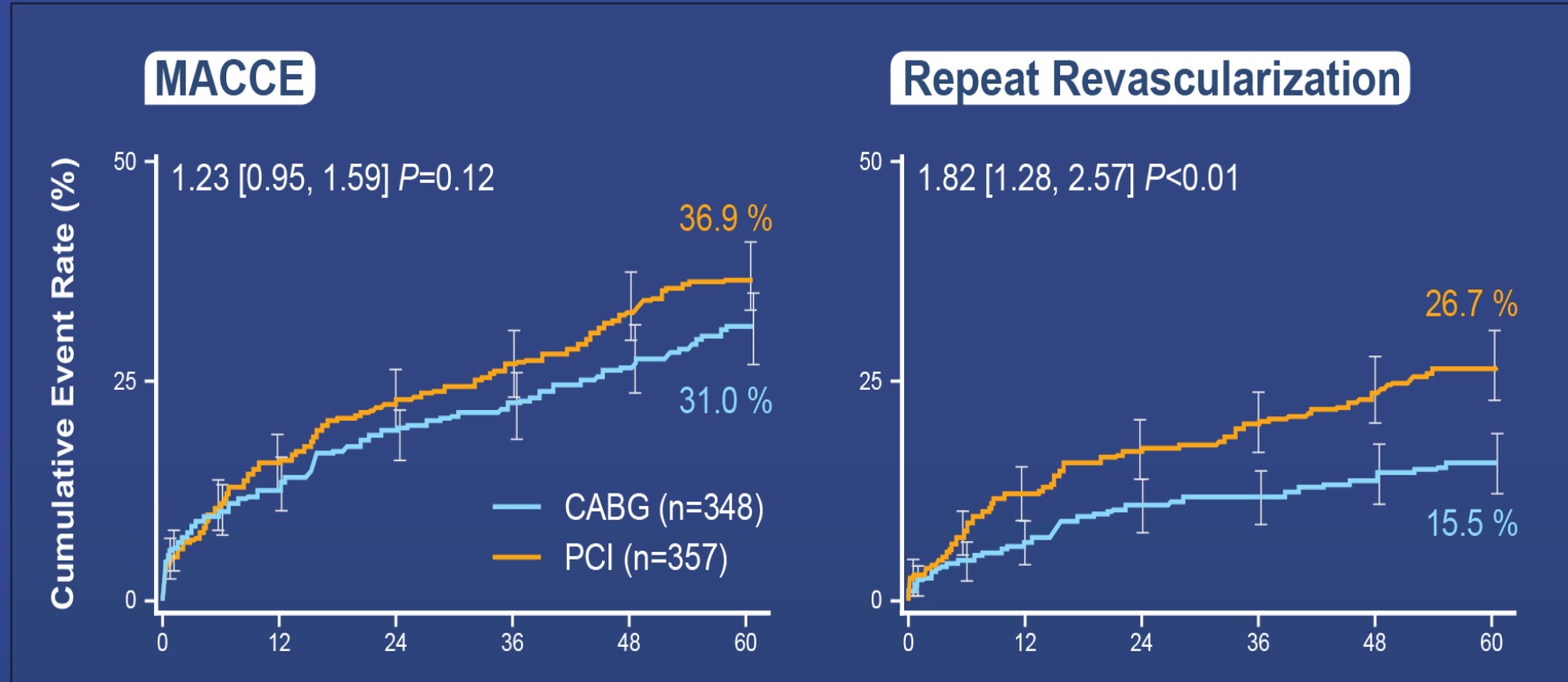

At 5 years, no difference in MACCE was found between PCI and CABG, but PCI was accompanied by a higher rate of repeat revascularization.

Long-term Outcomes of PCI vs. CABG

5-year outcomes of the LM subgroup of the **SYNTAX** trial
:PCI (N=357) vs. CABG (N=348)

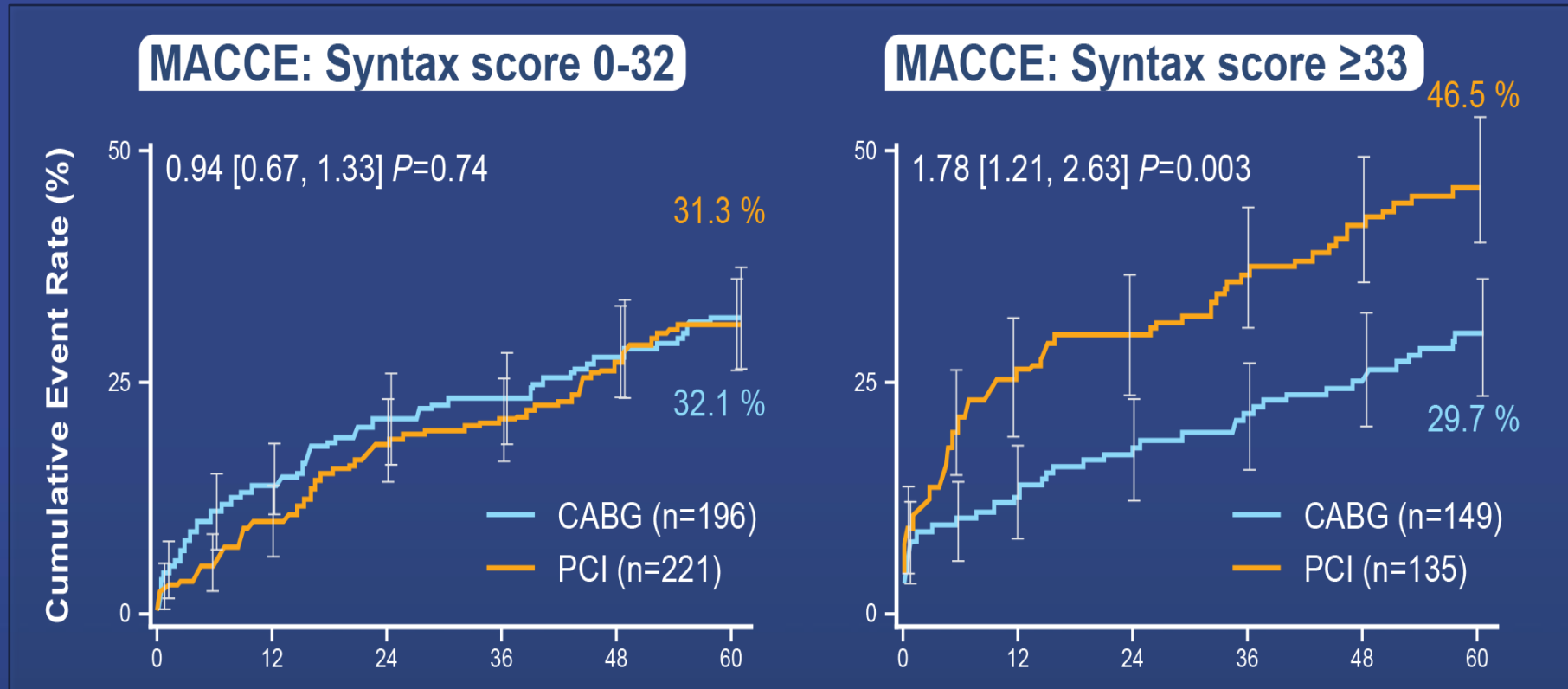

MACCE were similar between arms in patients with low/intermediate SYNTAX scores but significantly increased in patients with high scores.

Long-term Outcomes of PCI vs. CABG

5-year outcomes of the randomized **PRECOMBAT** trial
:PCI (N=300) vs. CABG (N=300)

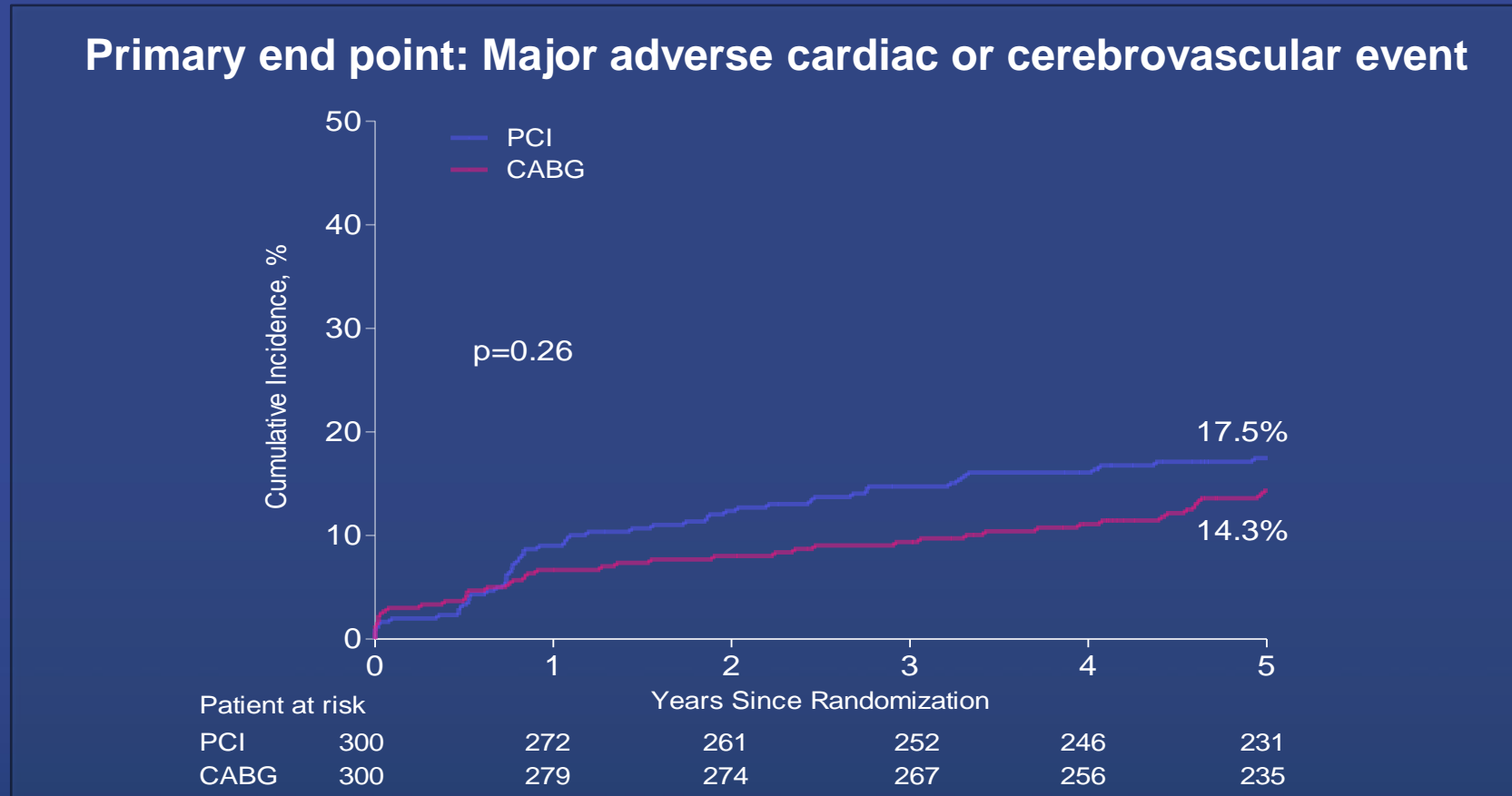

During 5 year follow-up, no significant difference in the rate of MACCE was observed between the PCI and CABG groups.

Long-term Outcomes of PCI vs. CABG

5-year outcomes of the randomized **PRECOMBAT** trial
:PCI (N=300) vs. CABG (N=300)

Primary end point: Major adverse cardiac or cerebrovascular event

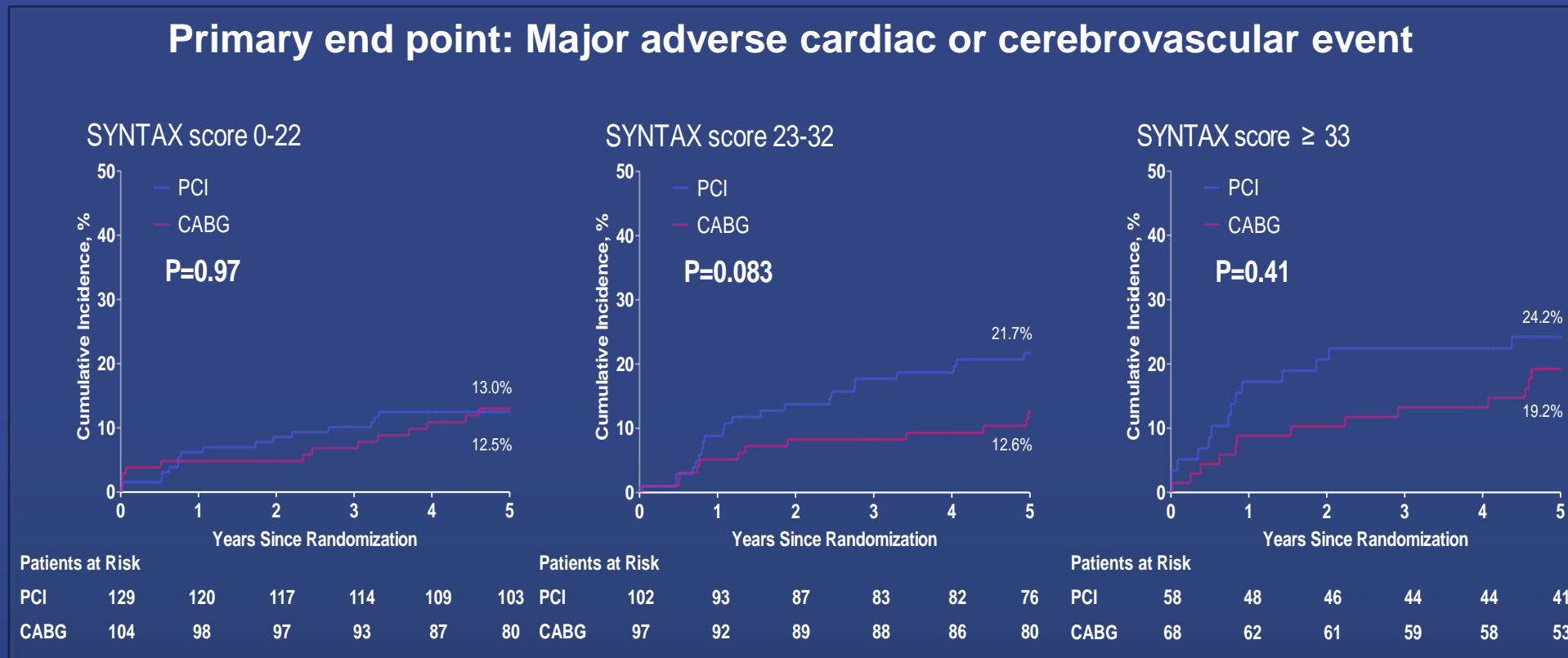

During 5 year follow-up, no significant difference in the rate of MACCE was observed between the PCI and CABG groups.

Temporal Trends

Data From the Asan Medical Center-LM Revascularization Registry

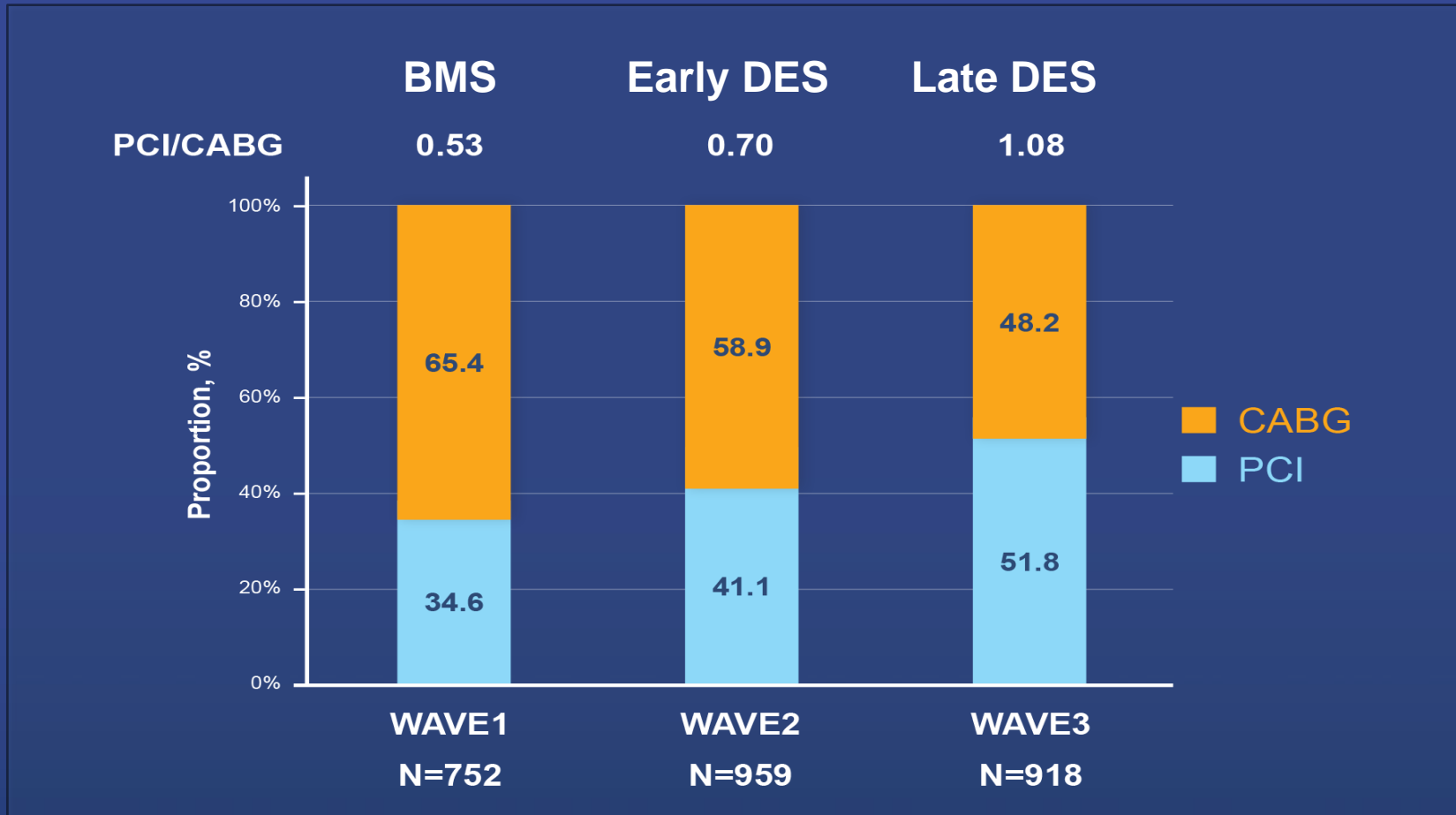

The proportion of PCI is significantly increasing.

Temporal Trends

Data From the Asan Medical Center-LM Revascularization Registry

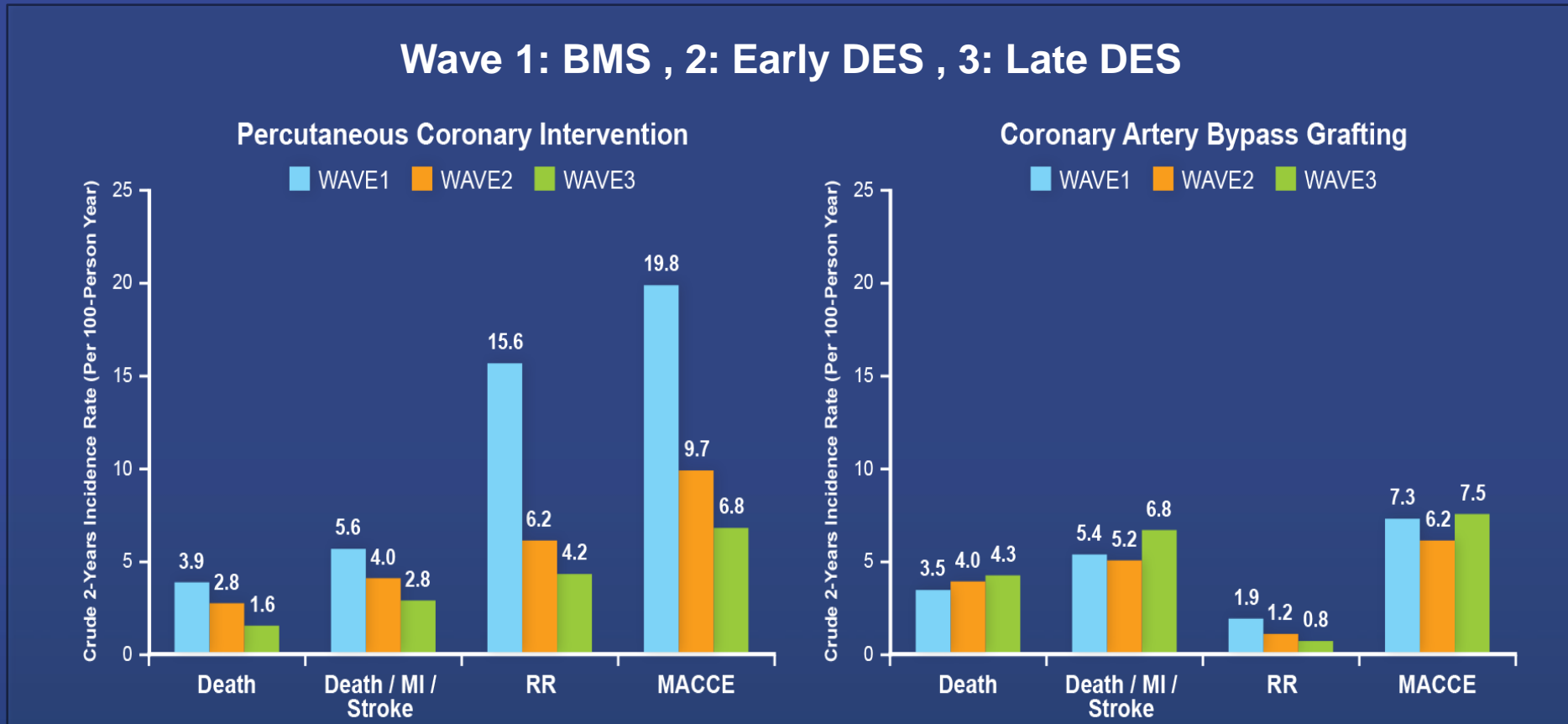

The incidence of adverse events is gradually decreasing with PCI, but the change has been insignificant with CABG.

Temporal Trends

Data From the [Asan Medical Center-LM](#) Revascularization Registry

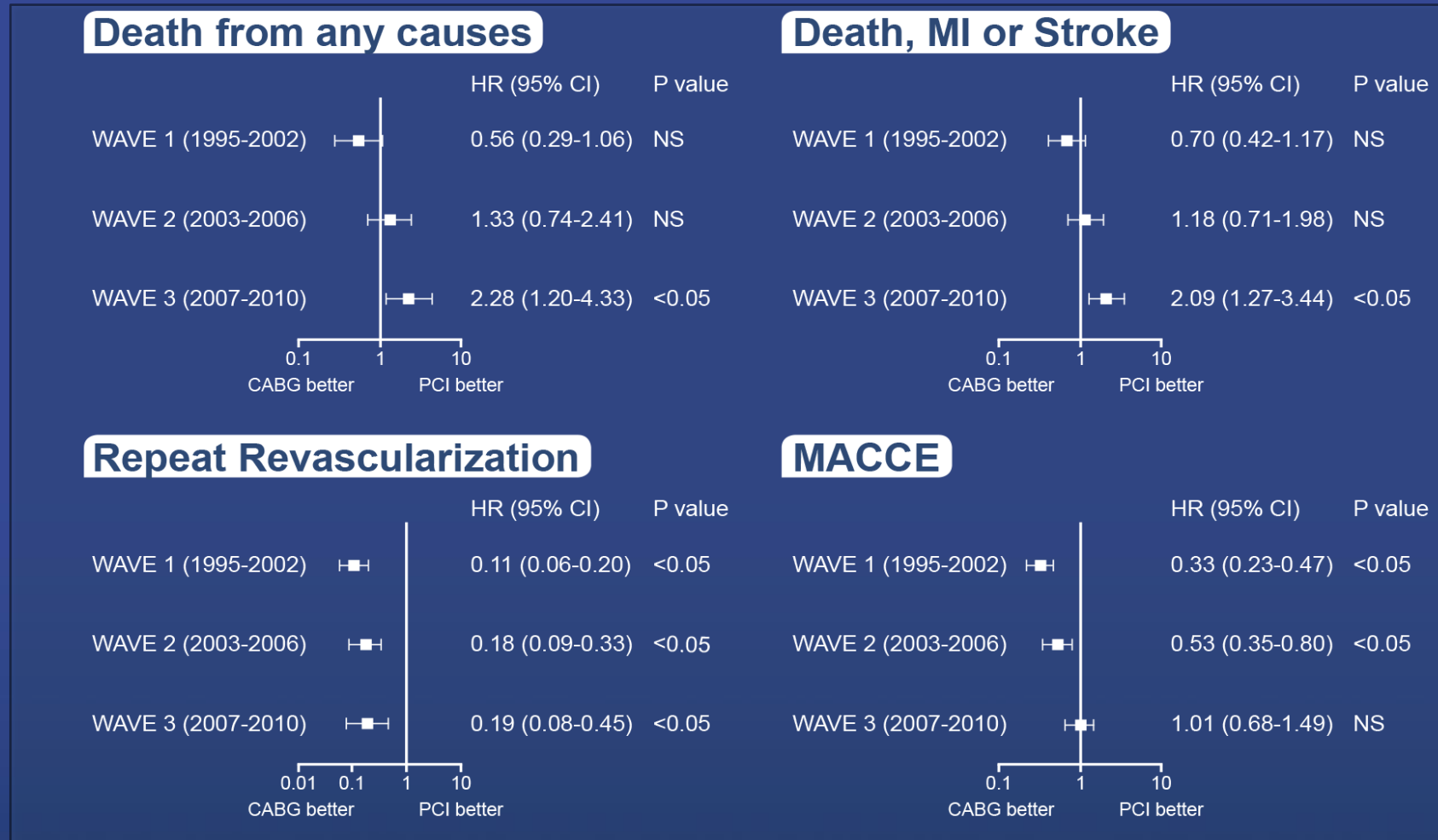

The trend favoring PCI was observed with the coronary stent evolving.

IRIS-MAIN registry

50 academic and community hospitals in Asia ($n=5883$)

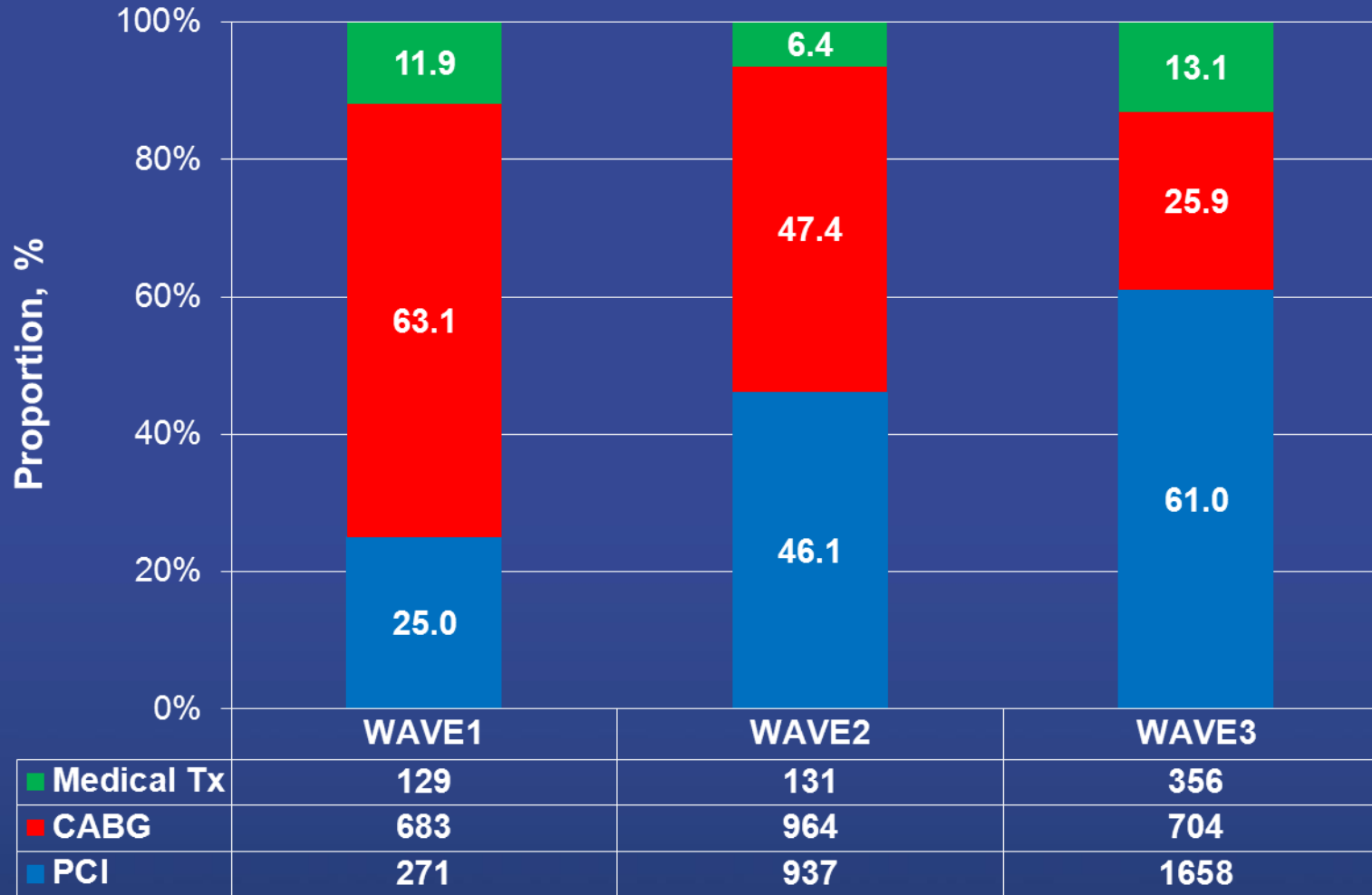

Historical time periods: WAVE1: 1995 – 2002, WAVE2: 2003 – 2006, WAVE3: 2007 – 2013

IRIS-MAIN registry

Medical Therapy Group

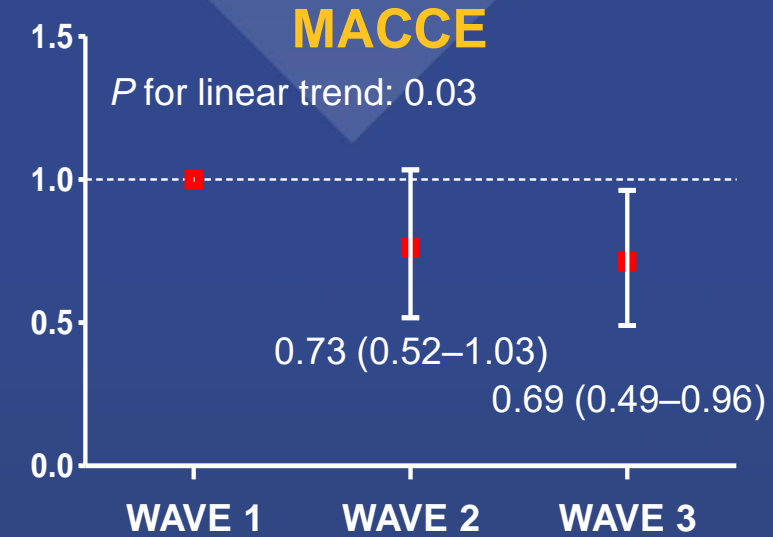
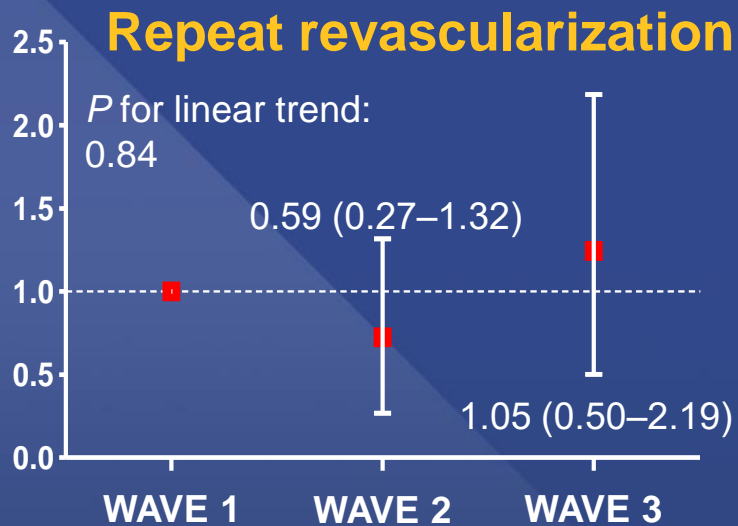
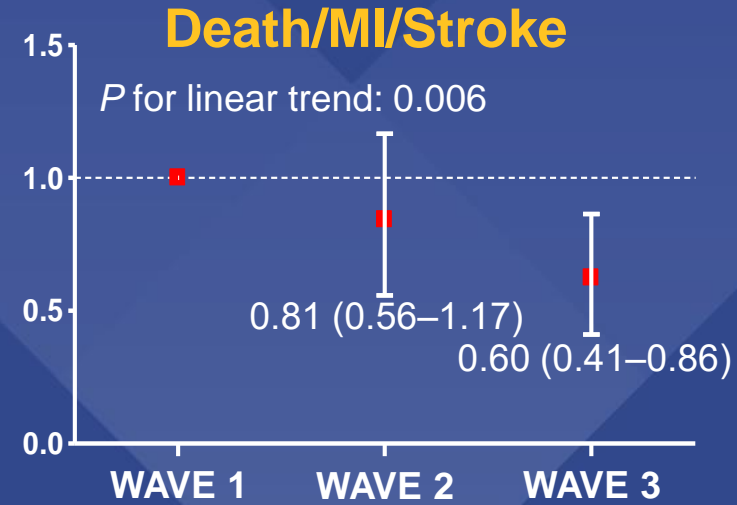

IRIS-MAIN registry

PCI Group

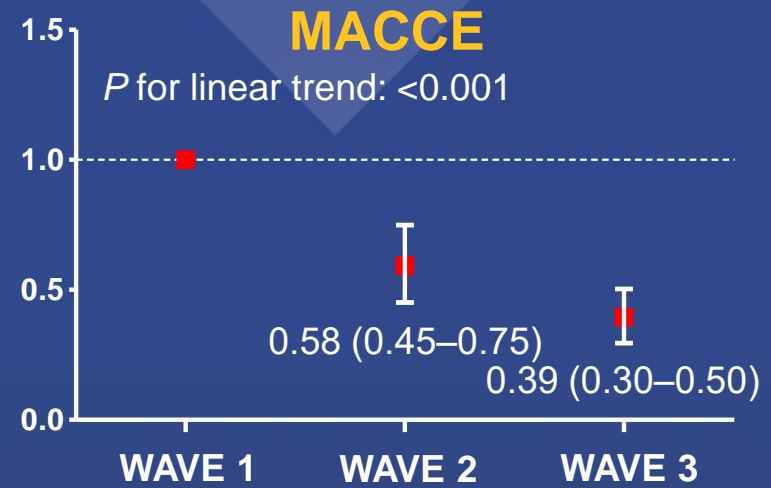
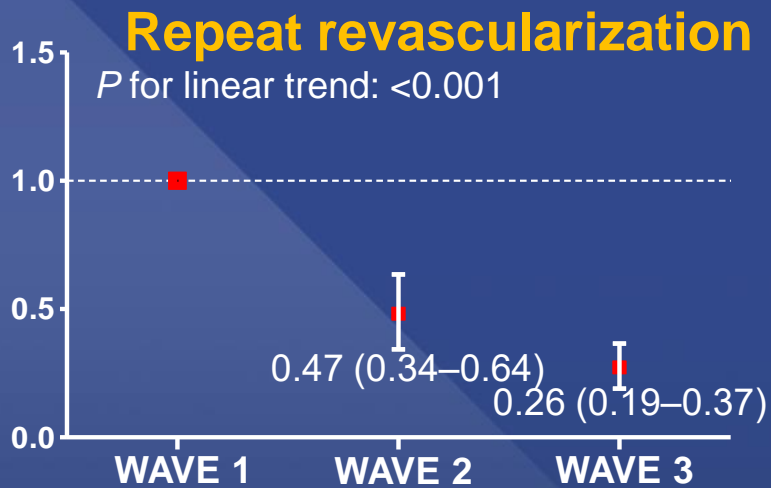
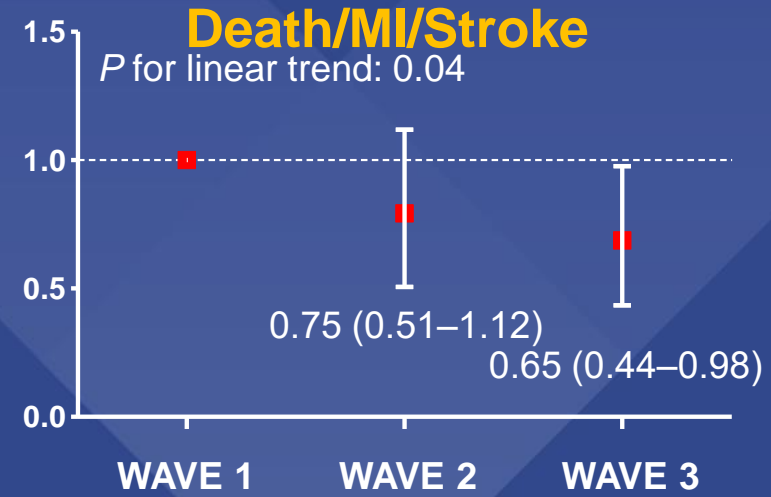
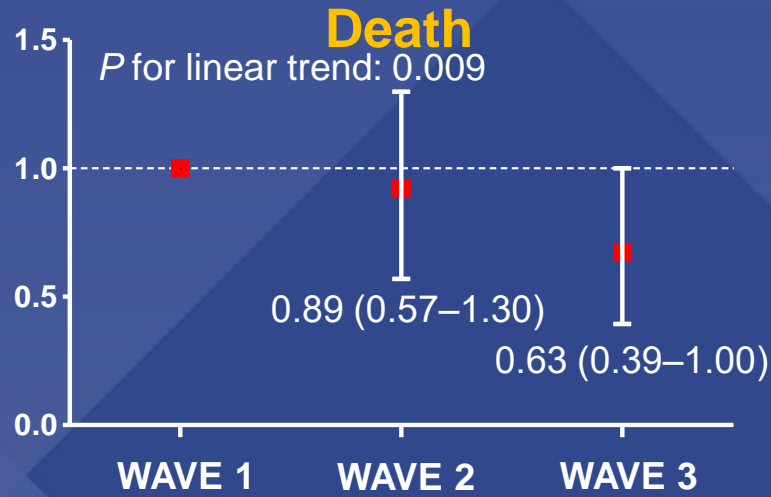

IRIS-MAIN registry

CABG Group

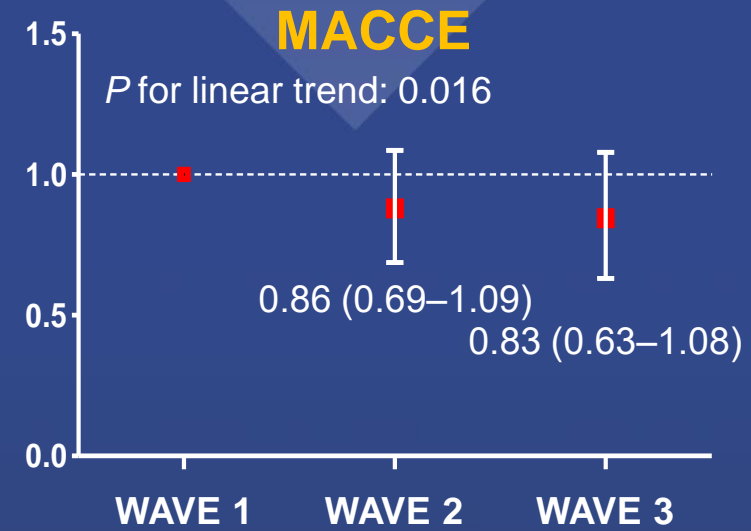
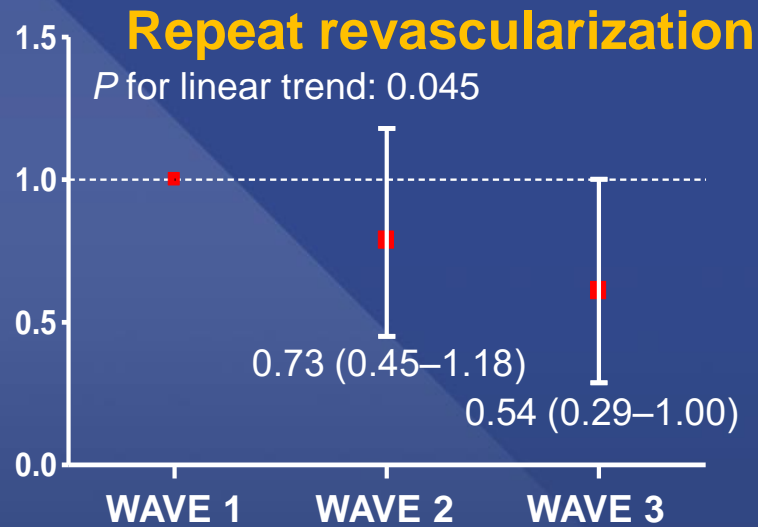
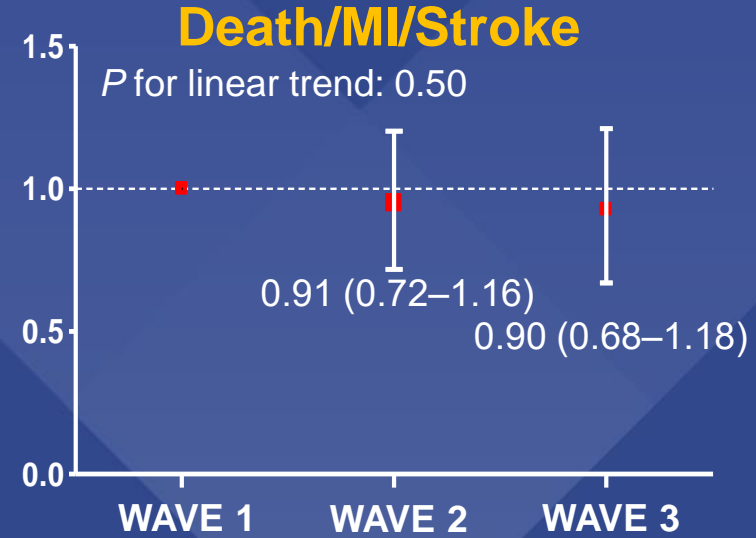
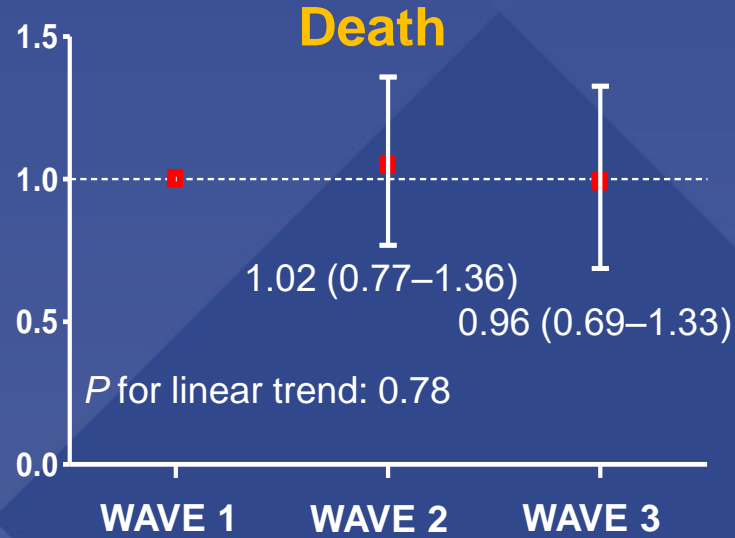

IRIS-MAIN registry

PCI versus Medical Tx

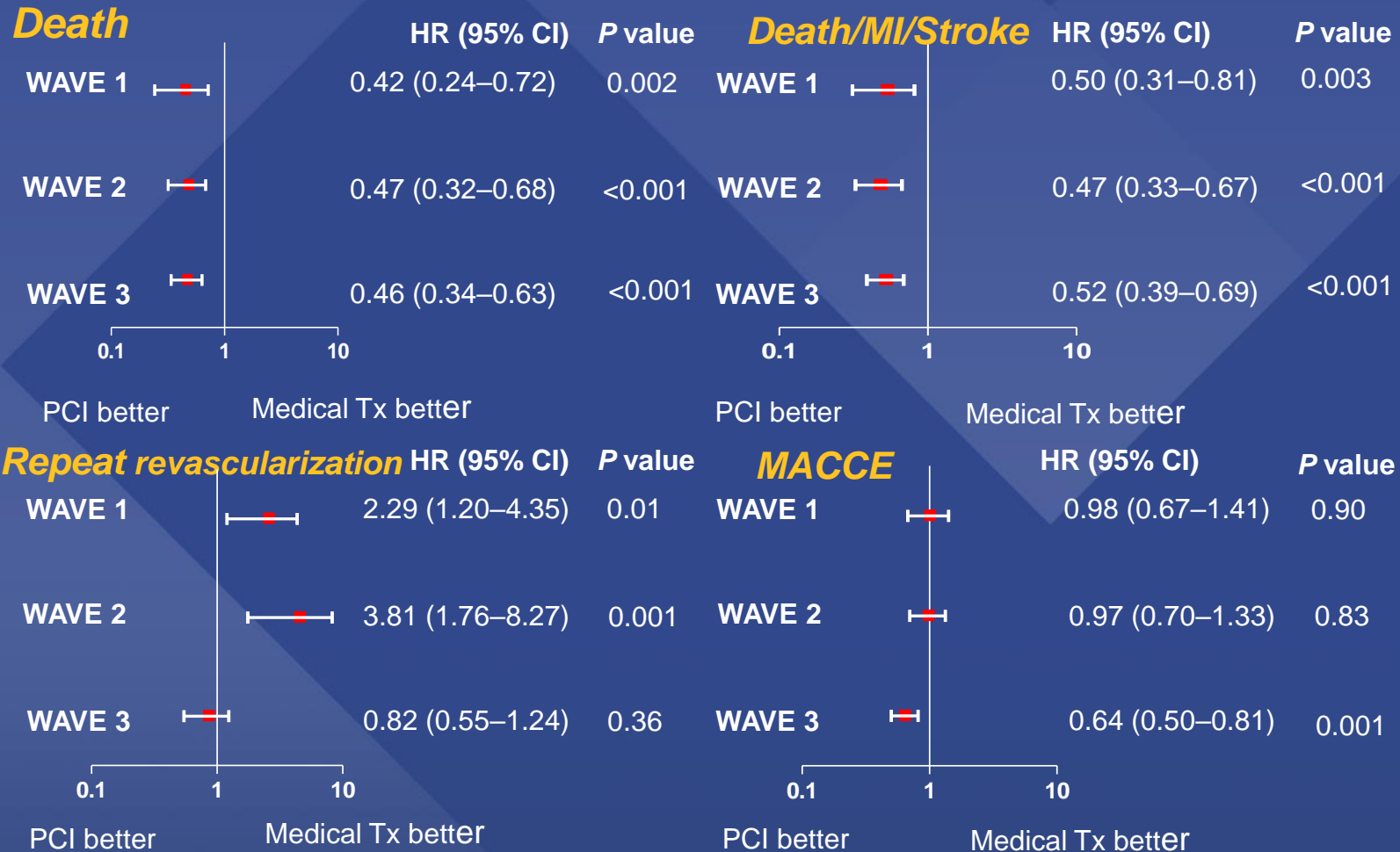

IRIS-MAIN registry

CABG versus Medical Tx

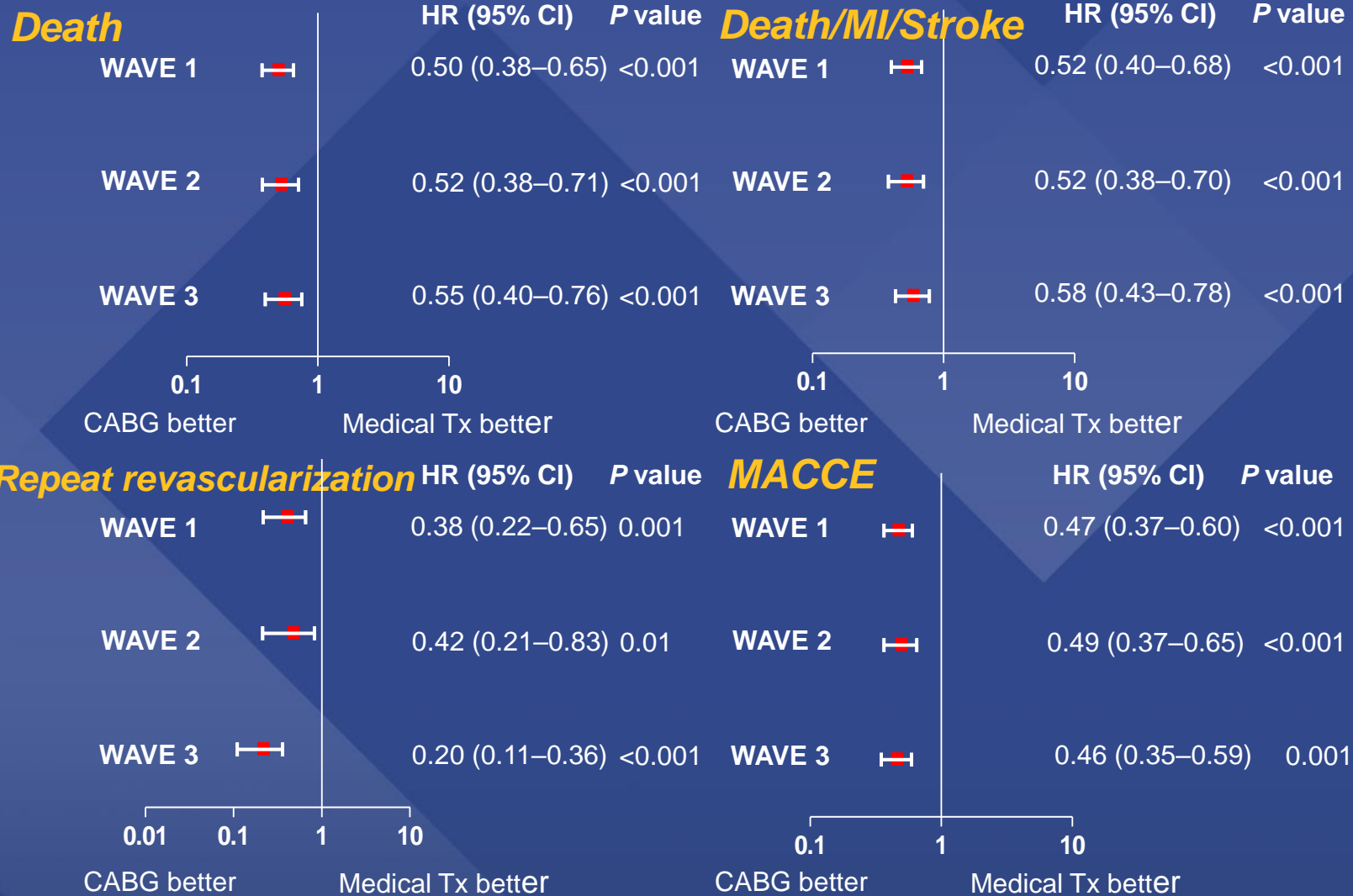

IRIS-MAIN registry

PCI versus CABG

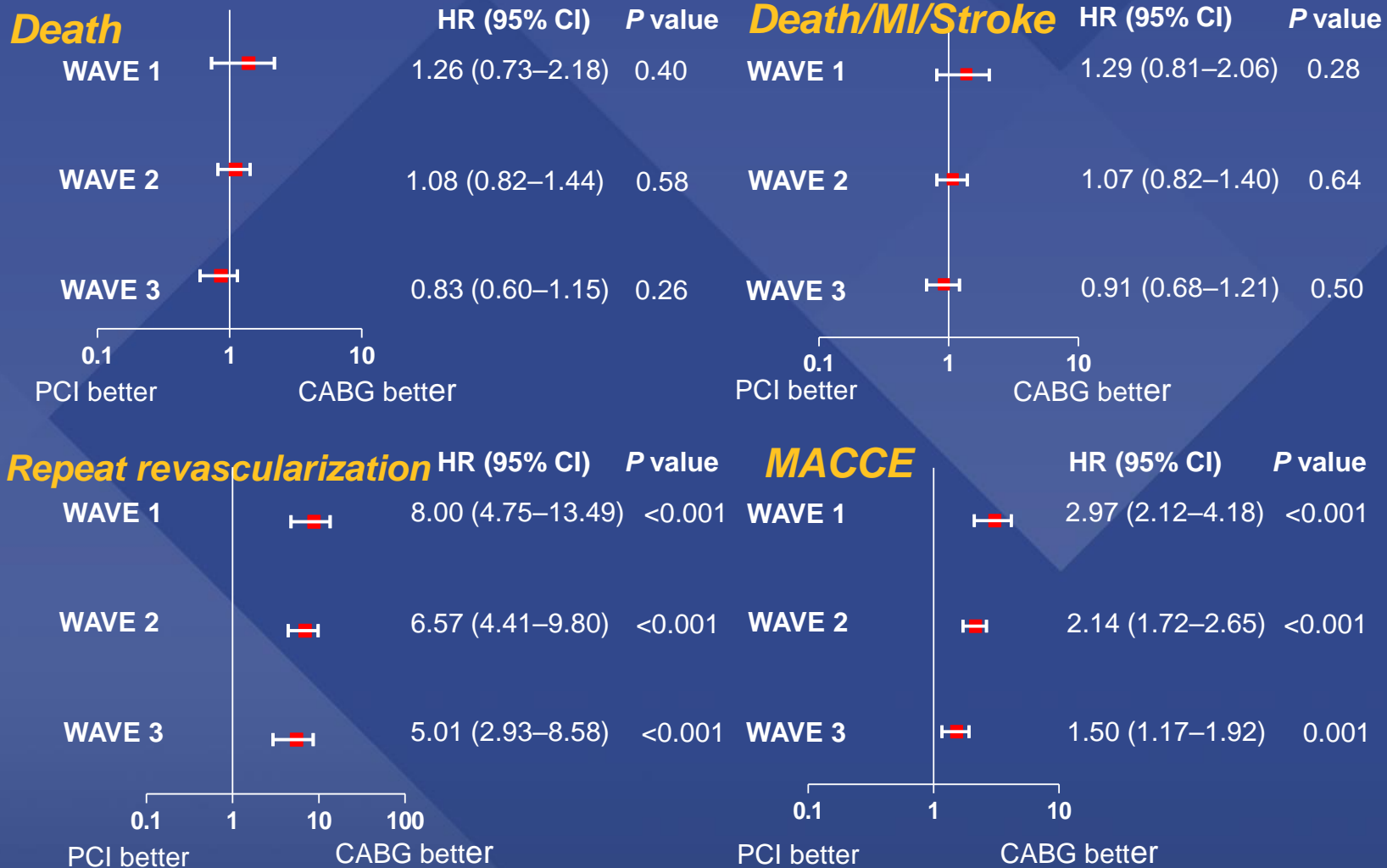

IRIS-MAIN registry

Secular Changes of Treatment Effect of Each Treatment Stratum

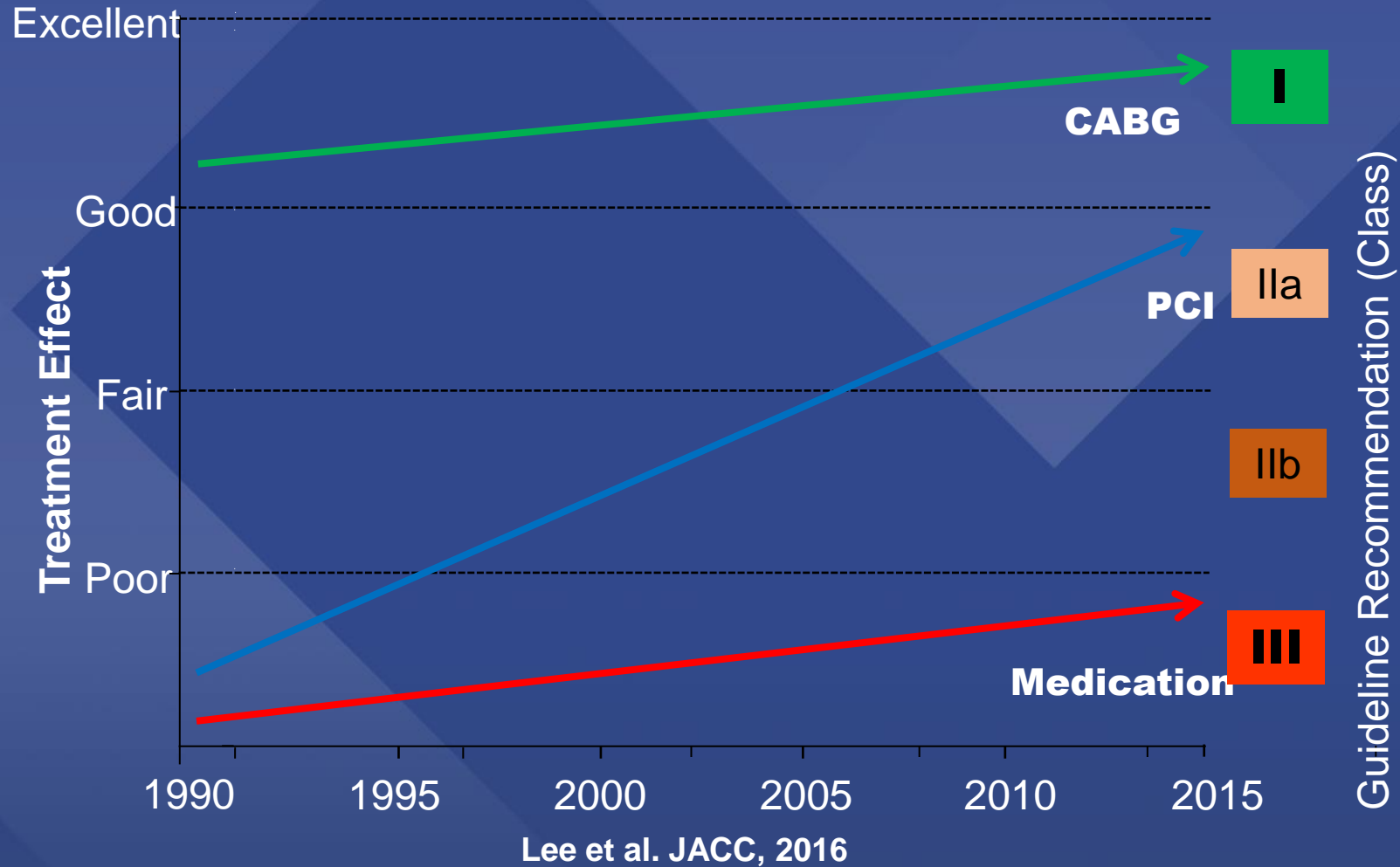

PCI vs. CABG for Left Main Disease

Meta-analysis of 4 RCTs, 1,611 Patients

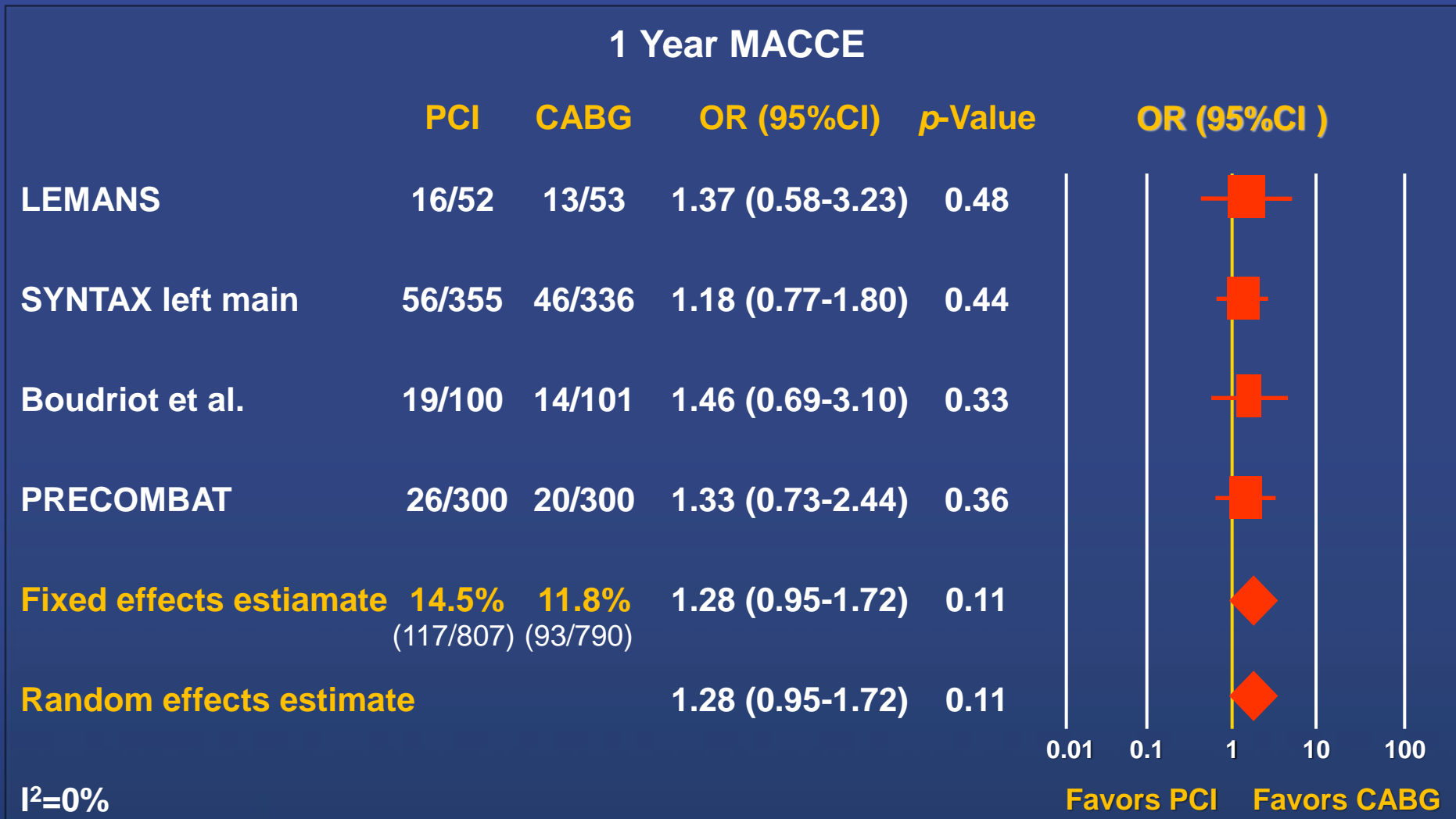

PCI vs. CABG for Left Main Disease

Meta-analysis of 24 studies, 14,203 patients

According to follow-up duration

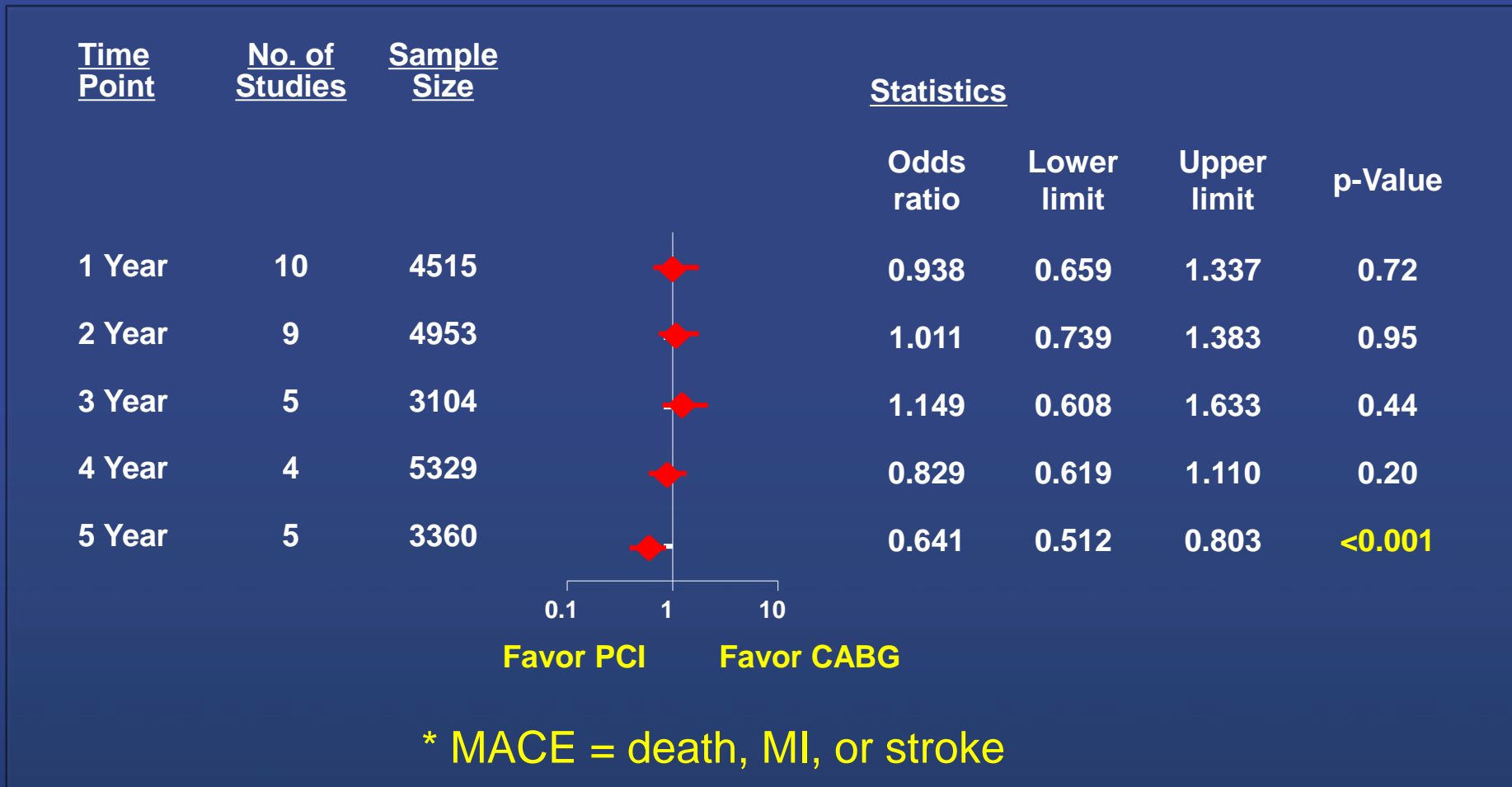

PCI vs. CABG for Left Main Disease

Meta-analysis of 24 studies, 14,203 patients

According to SYNTAX score

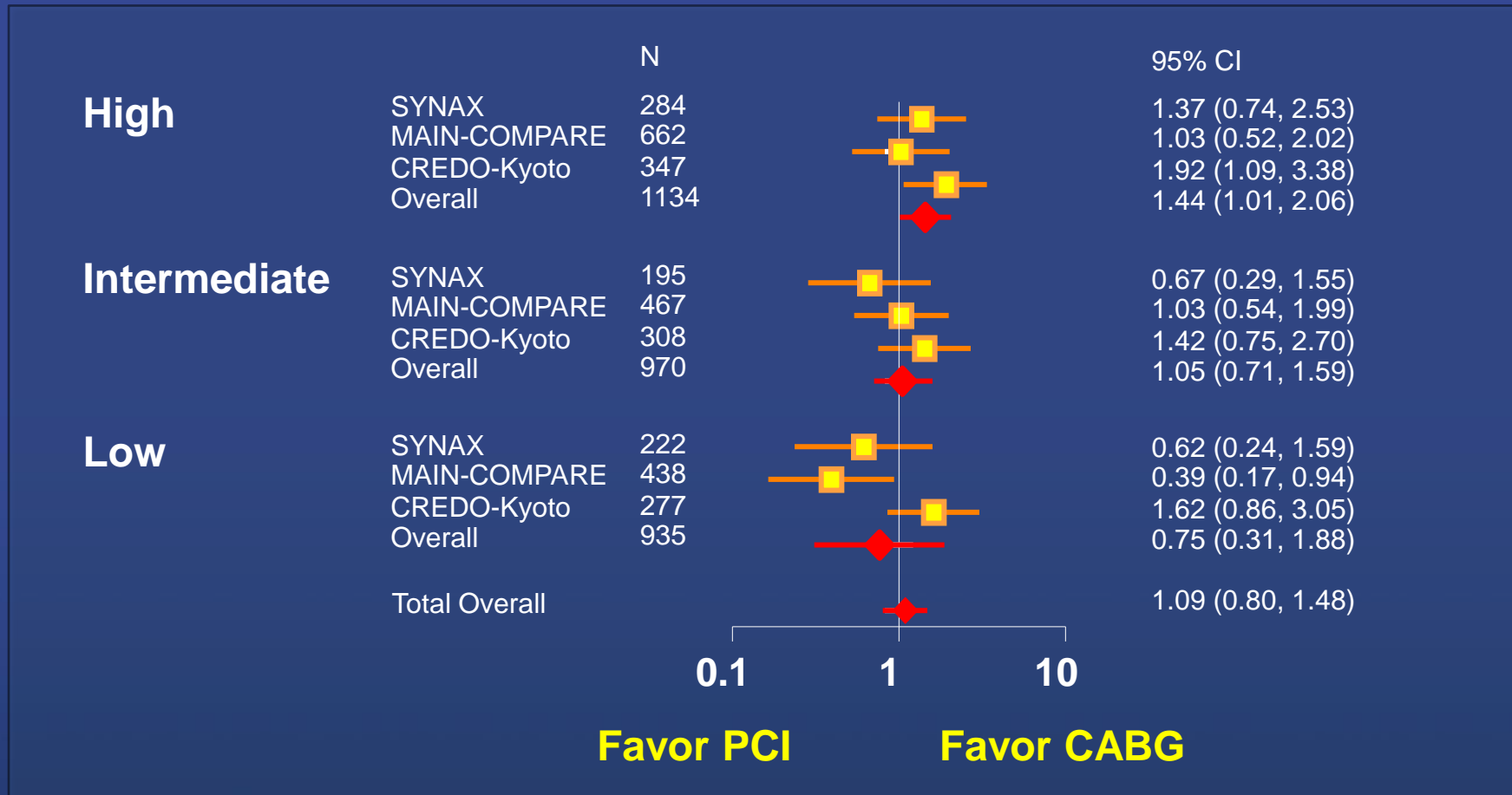

PCI vs. CABG for Left Main Disease

5-year clinical outcomes of the randomized **NOBLE** trial

:PCI (N=592) vs. CABG (N=592)

Primary Endpoint: MACCE, All-cause mortality

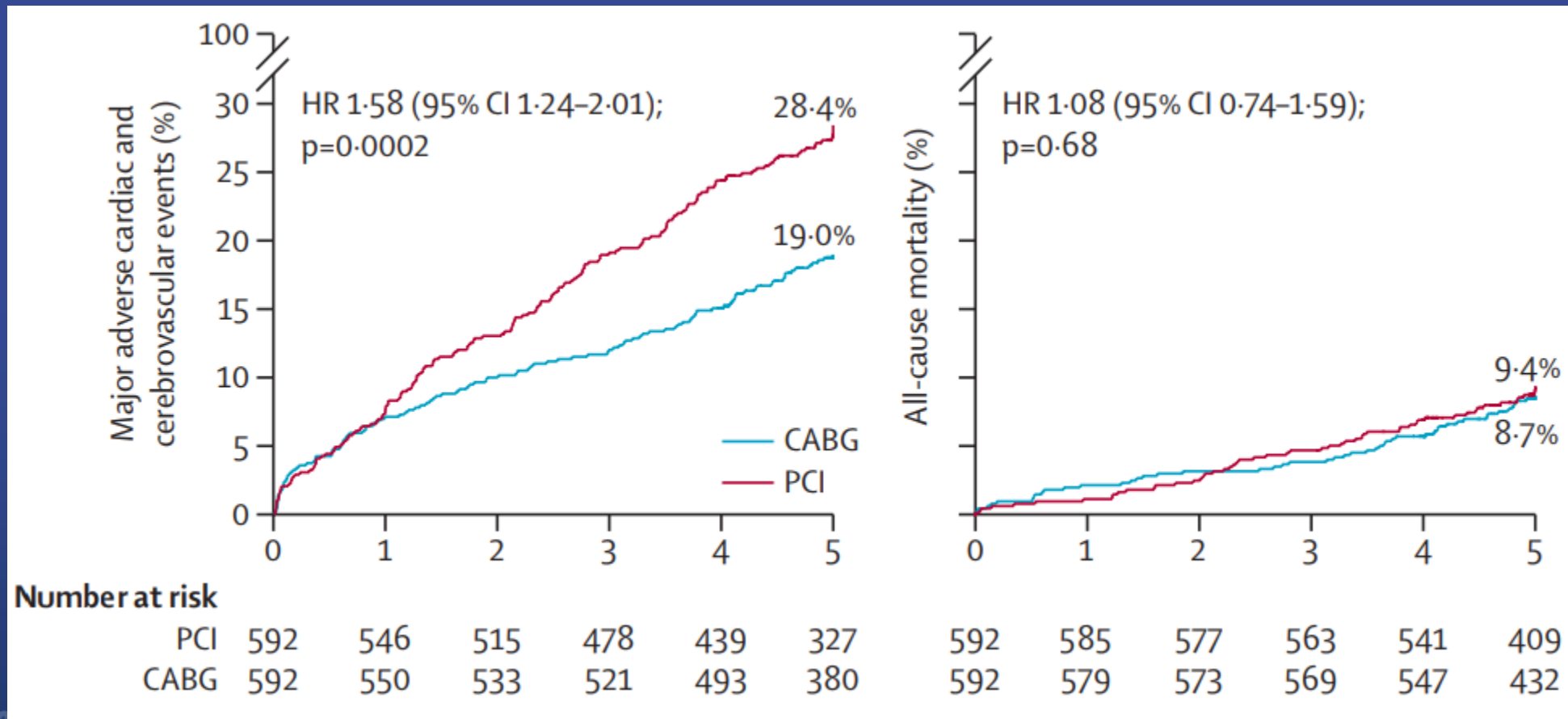

Holm NR et al. Lancet 2020.

PCI vs. CABG for Left Main Disease

5-year clinical outcomes of the randomized **NOBLE** trial

:PCI (N=592) vs. CABG (N=592)

Primary Endpoint: Non-procedural MI, Repeat revascularization

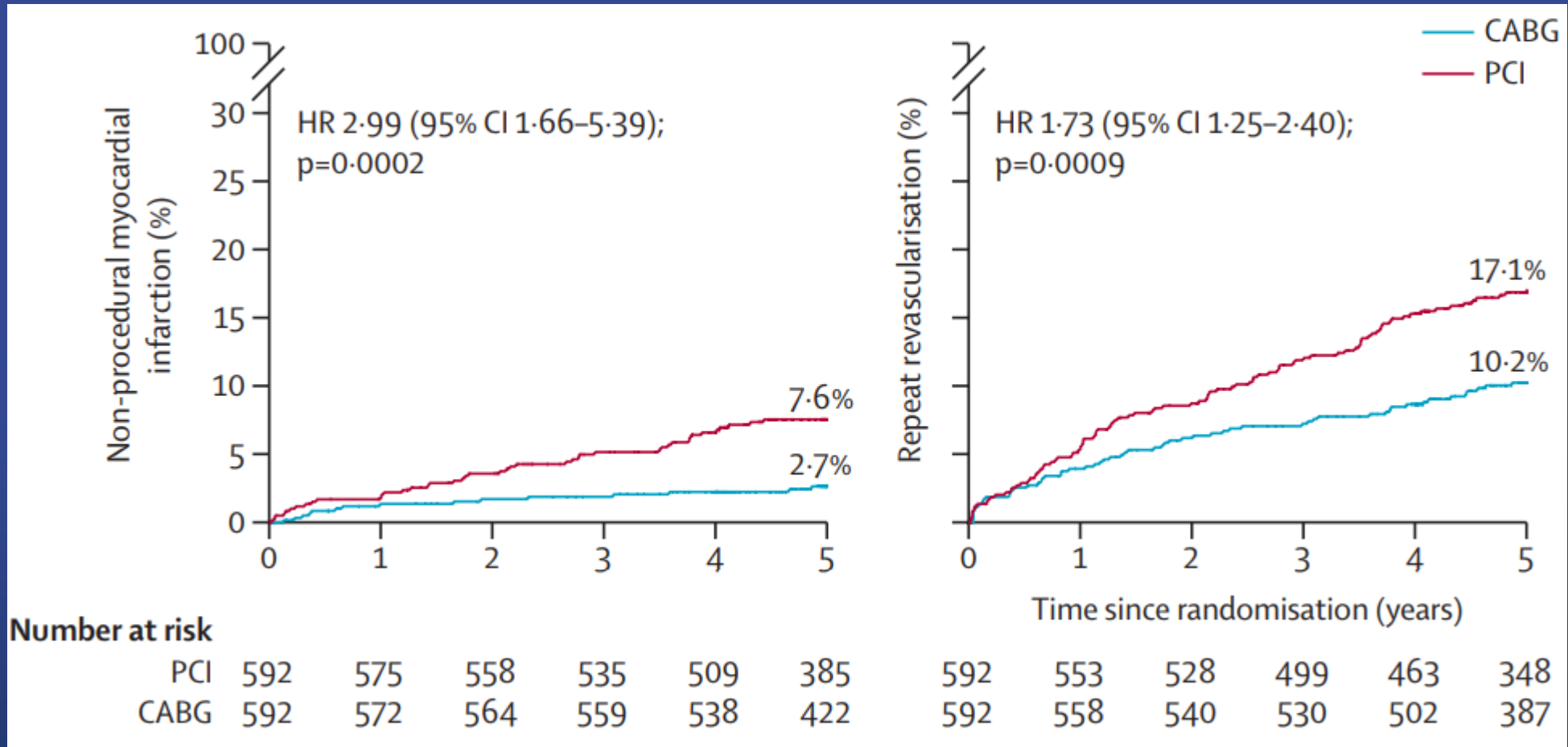

PCI vs. CABG for Left Main Disease

5-year clinical outcomes of the randomized **NOBLE** trial

:PCI (N=592) vs. CABG (N=592)

Primary Endpoint: Stroke

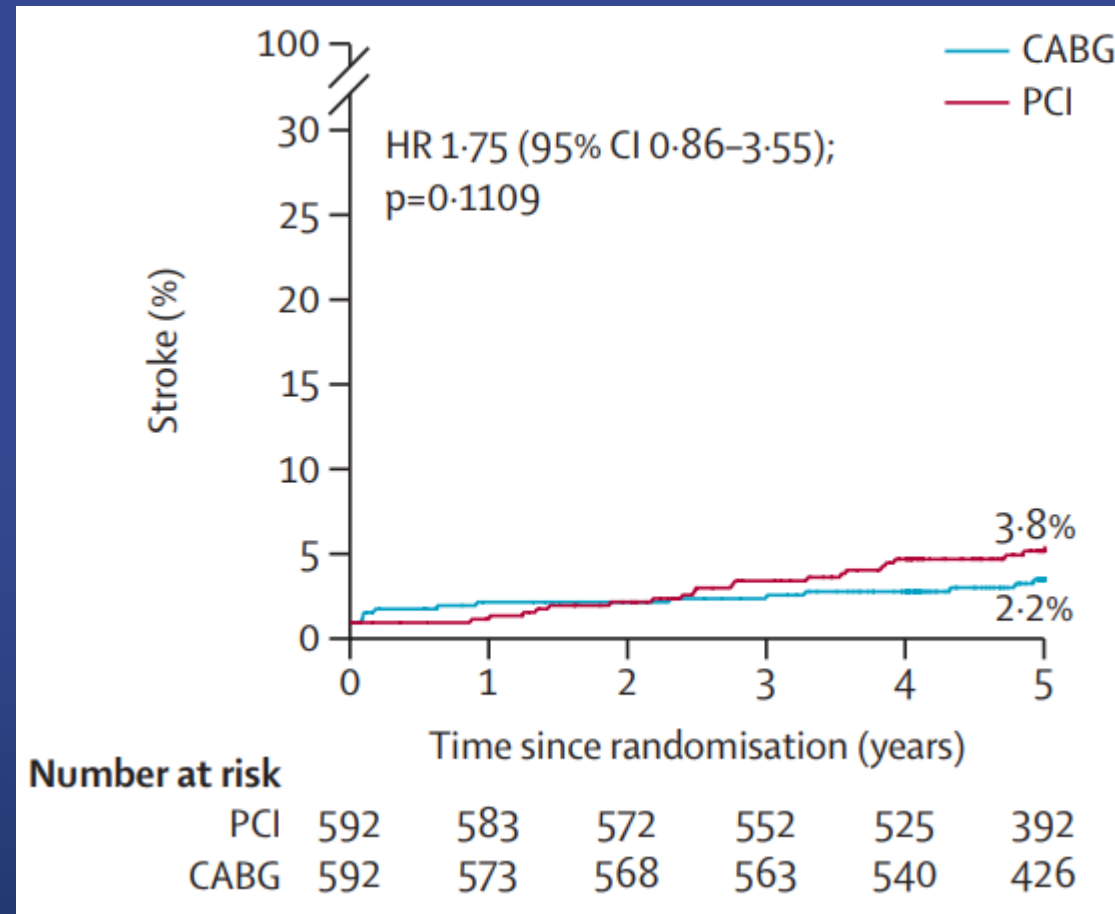

Holm NR et al. Lancet 2020.

PCI vs. CABG for Left Main Disease

5-year clinical outcomes of the randomized **NOBLE** trial

:PCI (N=592) vs. CABG (N=592)

Primary Endpoint(MACCE) by SYNTAX score subgroups

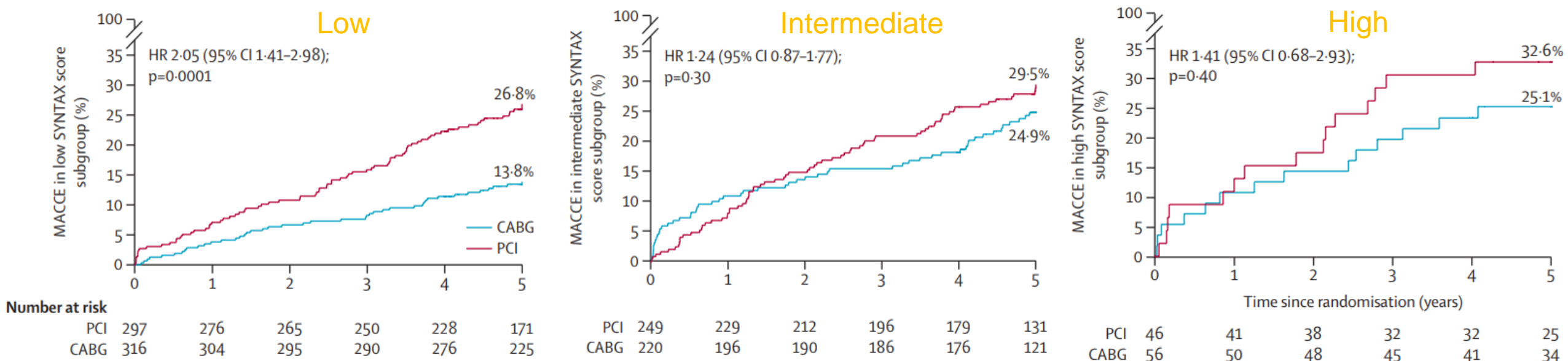

A low score is defined as 1–22; intermediate is 23–32; high is ≥33.

PCI vs. CABG for Left Main Disease

5-year outcomes of the randomized **EXCEL** trial
:PCI (N=948) vs. CABG (N=957)

	PCI (n=948)	CABG (n=957)	Diff [95% CI]	OR [95%CI]
Primary endpoint				
Death, stroke or MI at 5 years	22.0%	19.2%	2.8 [-0.9 to 6.0]	1.19 (0.95-1.05)
Secondary endpoints				
Death from any cause	13.0%	9.9%	3.1 [0.2 to 6.1]	1.38 (1.03-1.85)
Death, stroke, MI or ischemia-driven revasc	31.3 %	24.9 %	6.2 [2.4-10.6]	1.39 (1.13-1.71)

PCI vs. CABG for Left Main Disease

5-year outcomes of the randomized [EXCEL](#) trial

:PCI (N=948) vs. CABG (N=957)

Primary Endpoint: Death, Stroke or MI at 5 Years

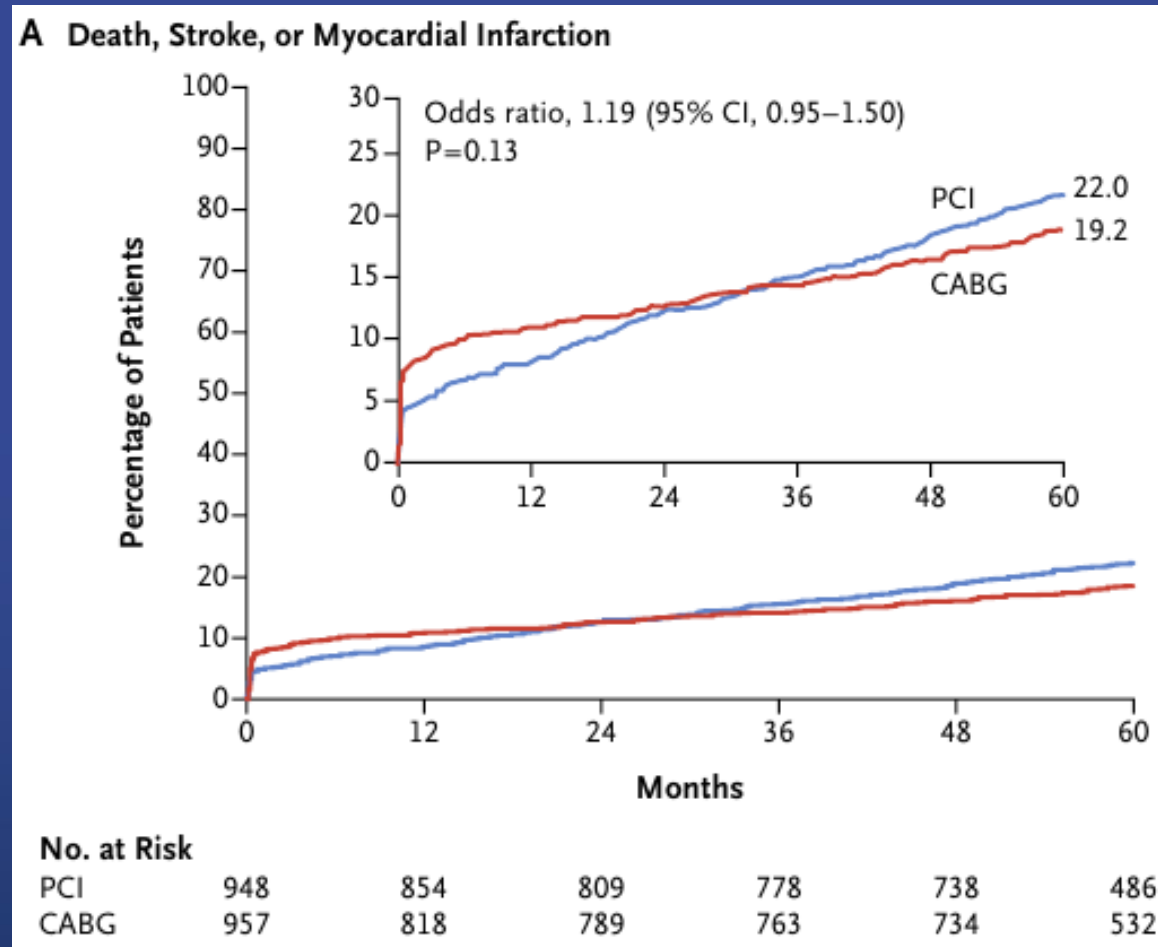

G.W. Stone et al. N Engl J Med 2019.

PCI vs. CABG for Left Main Disease

5-year outcomes of the randomized **EXCEL** trial
:PCI (N=948) vs. CABG (N=957)

Death, Stroke, MI or Ischemia-driven Revascularization at 5 Years

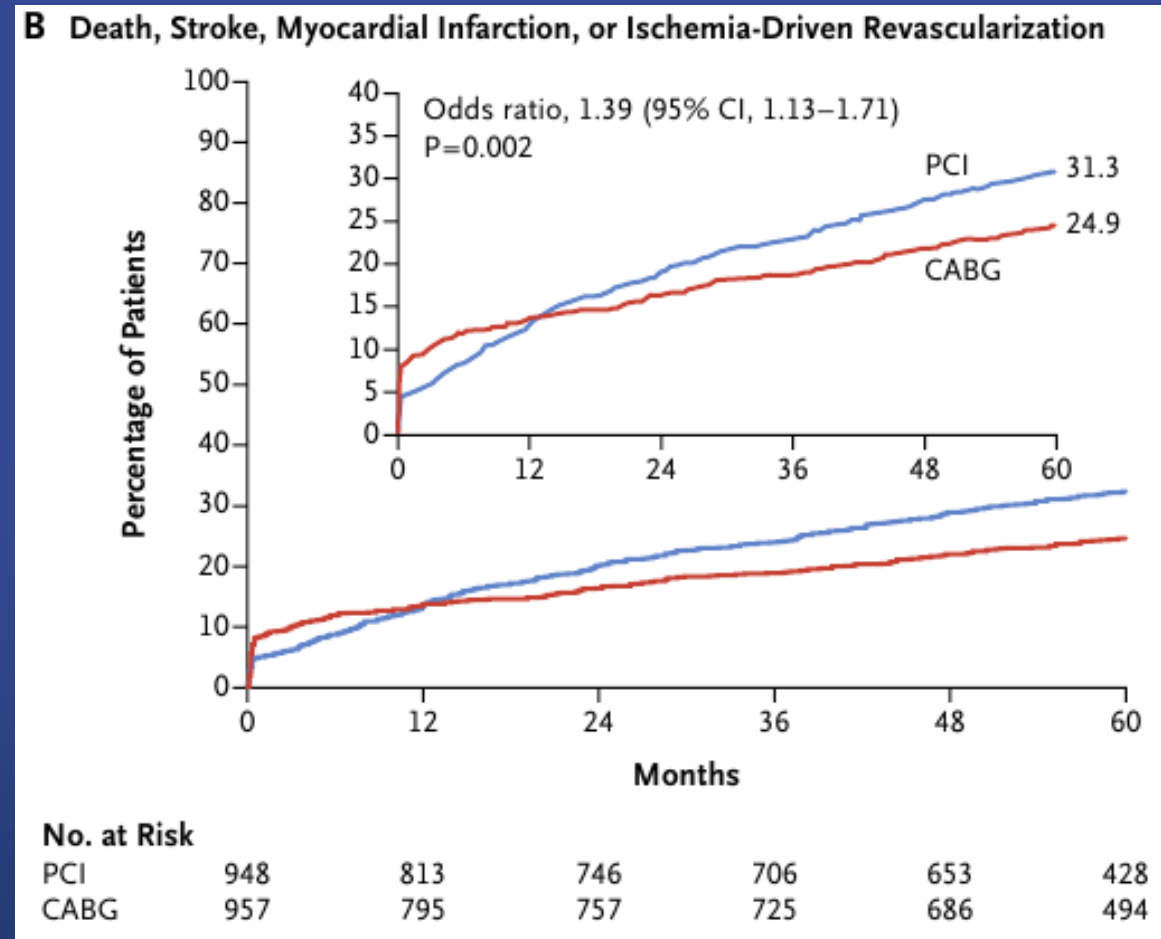

PCI vs. CABG for Left Main Disease

5-year outcomes of the randomized [EXCEL](#) trial

:PCI (N=948) vs. CABG (N=957)

Secondary Outcomes Analysis

Outcome	PCI (N=948)		CABG (N=957)		Difference in Event Rates (95% CI)	Odds Ratio (95% CI)
	Events	Event Rate	Events	Event Rate		
	<i>no.</i>	<i>%</i>	<i>no.</i>	<i>%</i>	<i>percentage points</i>	
Death from any cause	119	13.0	89	9.9	3.1 (0.2 to 6.1)	1.38 (1.03 to 1.85)
Cardiovascular	61	6.8	49	5.5	1.3 (-0.9 to 3.6)	1.26 (0.85 to 1.85)
Definite cardiovascular	45	5.0	40	4.5	0.5 (-1.4 to 2.5)	1.13 (0.73 to 1.74)
Undetermined cause	16	1.9	9	1.1	0.9 (-0.3 to 2.0)	1.78 (0.78 to 4.06)
Noncardiovascular	58	6.6	40	4.6	2.0 (-0.2 to 4.2)	1.47 (0.97 to 2.23)
Stroke	26	2.9	33	3.7	-0.8 (-2.4 to 0.9)	0.78 (0.46 to 1.31)
Myocardial infarction	95	10.6	84	9.1	1.4 (-1.3 to 4.2)	1.14 (0.84 to 1.55)
Periprocedural	37	3.9	57	6.1	-2.1 (-4.1 to -0.1)	0.63 (0.41 to 0.96)
Nonperiprocedural	59	6.8	31	3.5	3.2 (1.2 to 5.3)	1.96 (1.25 to 3.06)
Ischemia-driven revascularization	150	16.9	88	10.0	6.9 (3.7 to 10.0)	1.84 (1.39 to 2.44)
PCI	125	14.1	80	9.1	4.9 (1.9 to 7.9)	1.65 (1.22 to 2.22)
CABG	38	4.3	8	0.9	3.4 (1.9 to 4.9)	4.90 (2.27 to 10.56)

G.W. Stone et al. N Engl J Med 2019.

PCI vs. CABG for Left Main Disease

5-year outcomes of the randomized [EXCEL](#) trial

:PCI (N=948) vs. CABG (N=957)

Additional Outcomes Analysis

Outcome	PCI (N=948)		CABG (N=957)		Difference in Event Rates (95% CI) percentage points	Odds Ratio (95% CI)
	Events	Event Rate	Events	Event Rate		
	<i>no.</i>	<i>%</i>	<i>no.</i>	<i>%</i>		
Additional outcomes						
Any revascularization	153	17.2	92	10.5	6.7 (3.5 to 9.9)	1.79 (1.36 to 2.36)
Stent thrombosis	16	1.8	0	0	—	—
Definite	10	1.1	0	0	—	—
Probable	6	0.7	0	0	—	—
Symptomatic graft stenosis or occlusion	0	0	58	6.5	—	—
Therapy failure†	10	1.1	58	6.5	-5.4 (-7.2 to -3.6)	0.16 (0.08 to 0.32)
Cerebrovascular events‡	29	3.3	46	5.2	-1.9 (-3.8 to 0)	0.61 (0.38 to 0.99)
Transient ischemic attack	3	0.3	14	1.6	-1.3 (-2.2 to -0.4)	0.21 (0.06 to 0.74)

PCI vs. CABG for Left Main Disease

5-year outcomes of the randomized **EXCEL** trial: **PCI (N=948)** vs. **CABG (N=957)**

Subgroup analysis of Primary outcomes at 5 Years

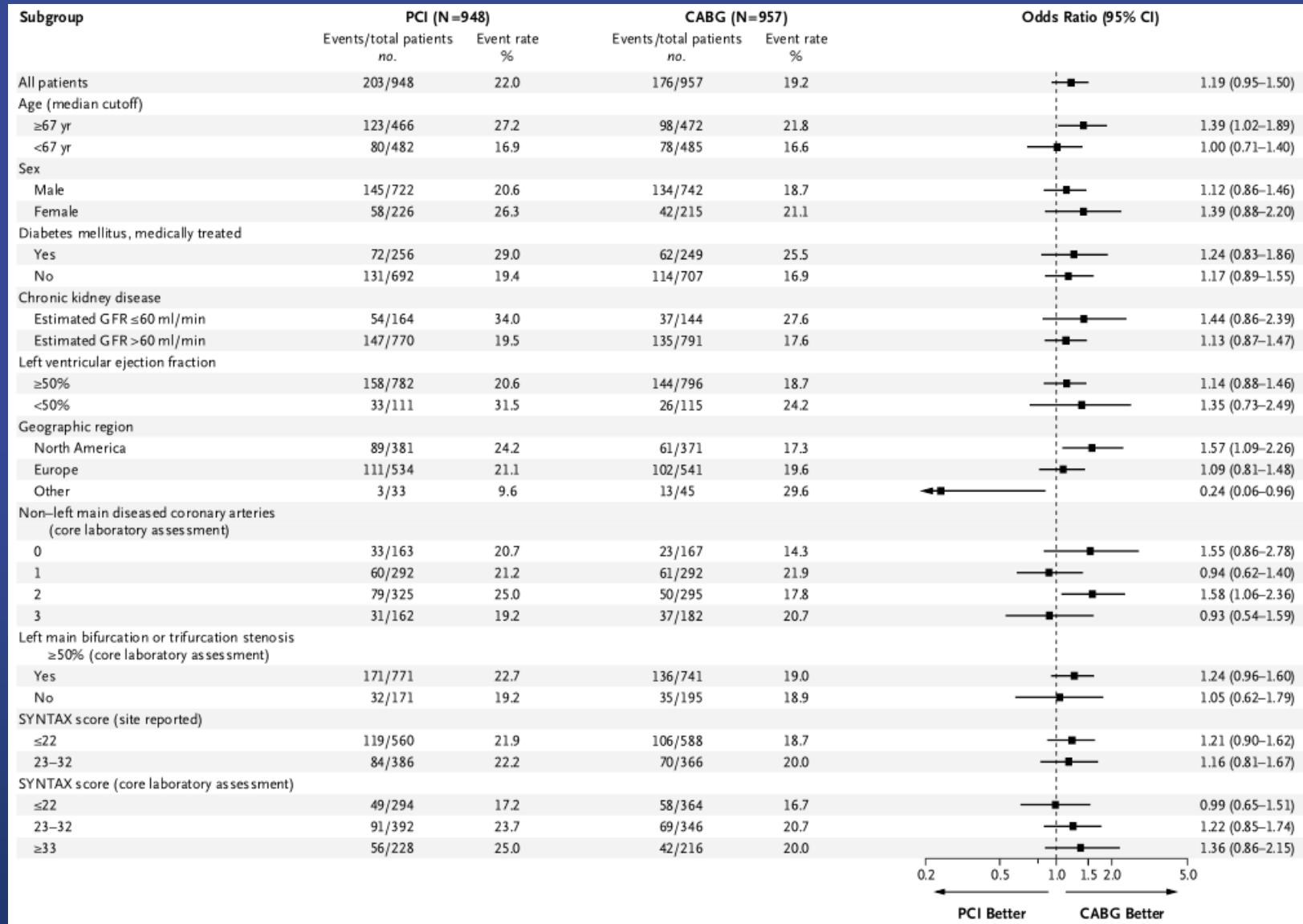

Role of Left Main PCI After EXCEL and NOBLE

Variables	EXCEL	NOBLE
Patients (no.)	1,905	1,201
Median follow-up	5 year	4.9 year
HR (95% CI), CABG/PCI		
Primary endpoint	1.19 (0.95-1.05)	1.58 (1.24-2.01)
All-cause death	1.38 (1.03-1.85)	1.08 (0.74-1.59)
Cardiac death	1.3 (-0.9-3.6)	0.99 (0.57-1.73)
MI	1.4 (-1.3-4.2)	2.99 (1.66-5.39)
Stroke	-0.8 (-2.4-0.9)	1.75 (0.86-3.55)
Revascularization	6.9 (3.7-10.0)	1.73(1.25-2.40)

NOBLE: Stent thrombosis (2% NOBLE vs. 1.8% EXCEL),
non-procedural MI excluded (3% CABG vs. 8% PCI)

Individual-patient-data Analysis from 11 PCI vs. CABG Trials

11,518 randomized pts; 4,478 (38.9%) with left main ds.

All-cause Mortality (Left Main)

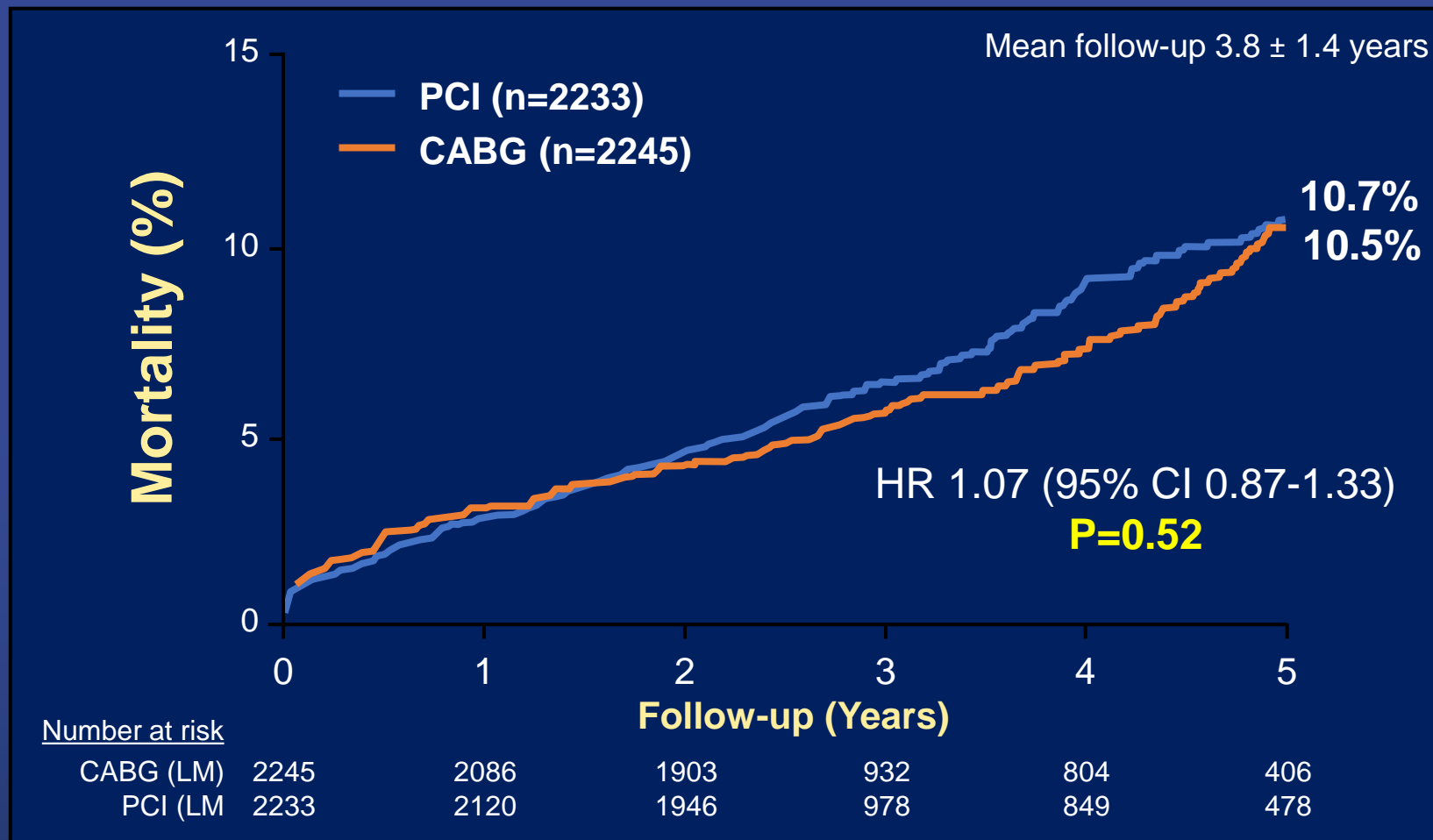

Individual-patient-data Analysis from 11 PCI vs. CABG Trials
 11,518 randomized pts; 4,478 (38.9%) with left main ds.

All-cause Mortality (LM patients)

	PCI (n=2,233)	CABG (n=2,245)	HR (95%CI)	P value	P _{int}
Overall mortality	10.7% (174)	10.5% (158)	1.07 [0.87, 1.33]	0.52	
Diabetes	16.5% (71)	13.4% (51)	1.34 [0.93, 1.91]	0.11	0.13
No diabetes	8.8% (104)	9.6% (107)	0.94 [0.72, 1.23]	0.65	
SYNTAX score 0-22	8.1% (45)	8.3% (49)	0.91 [0.60, 1.36]	0.64	0.38 (0.06 for trend)
SYNTAX score 23-32	10.8% (67)	12.7% (63)	0.92 [0.65, 1.30]	0.65	
SYNTAX score ≥33	15.0% (56)	12.4% (45)	1.39 [0.94, 2.06]	0.10	

PCI vs. CABG for Left Main Disease

10-year outcomes of the randomized SYNTAX Extended Survival (SYNTAXES) study: *PCI* (N=357) vs. *CABG* (N=348)

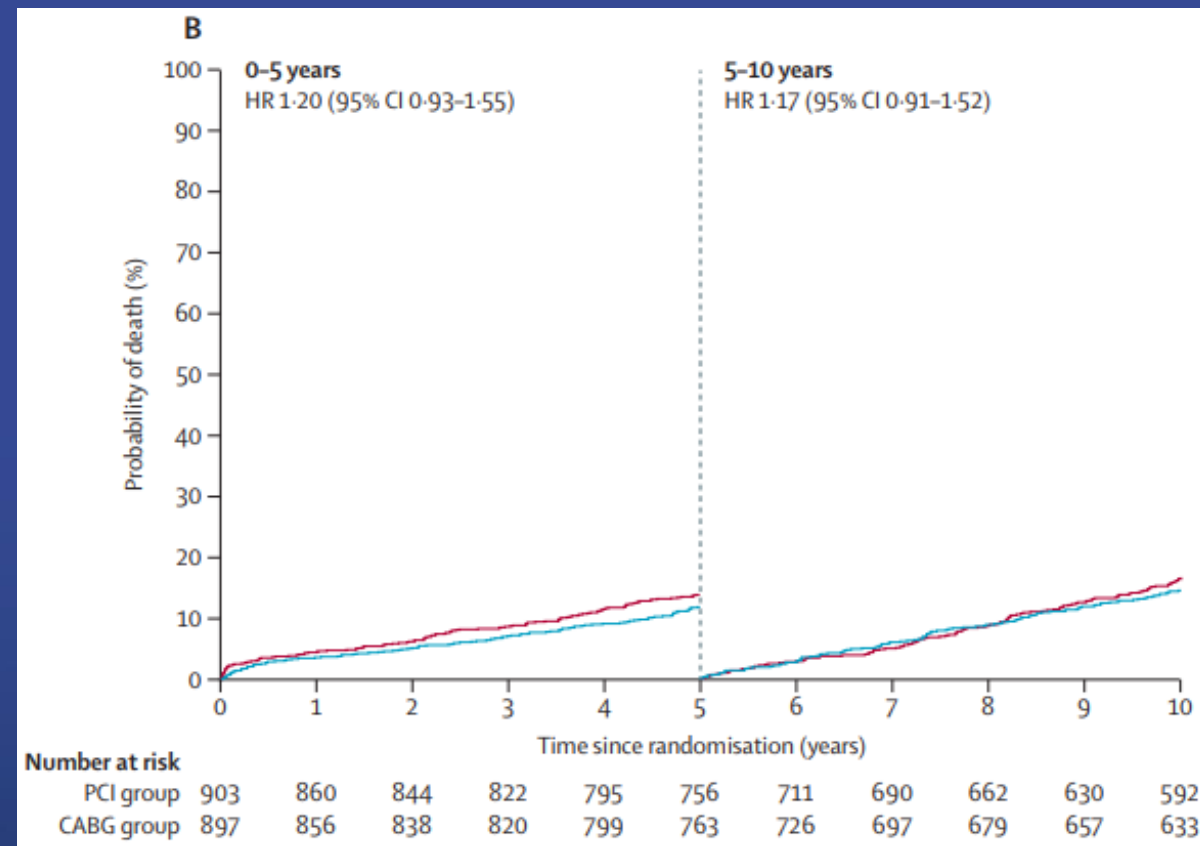
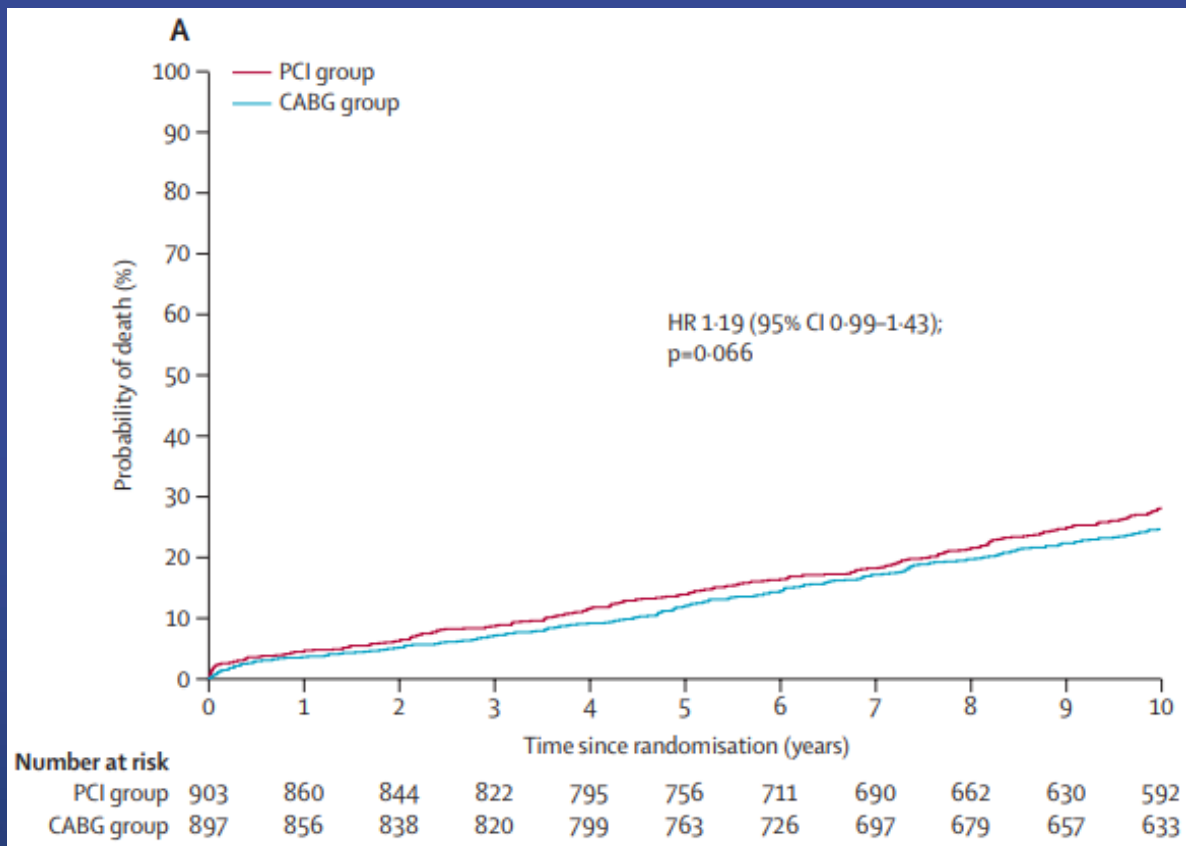

PCI vs. CABG for Left Main Disease

10-year outcomes of the randomized SYNTAX Extended Survival (SYNTAXES) study: *PCI* (N=357) vs. *CABG* (N=348)

Prespecified Subgroup analysis of 10-year all-cause death

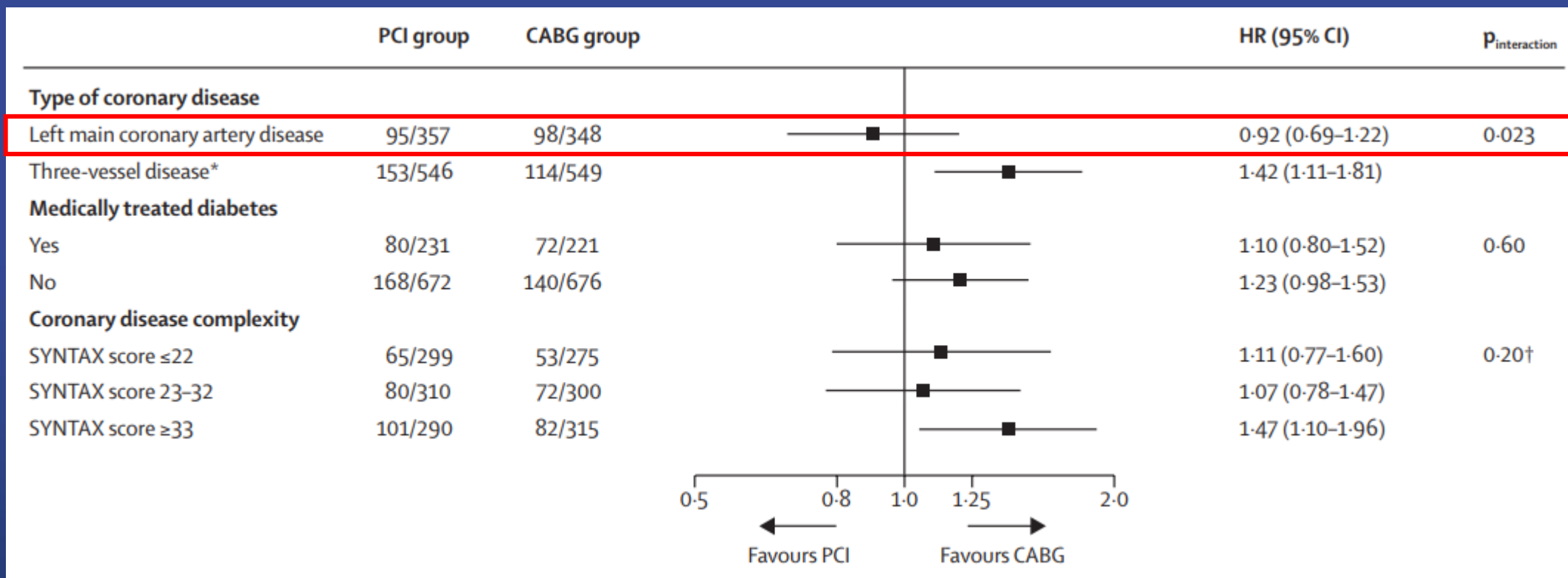

MAIN COMPARE Registry, 3-Year

Adjusted HR by Use of PS Matching

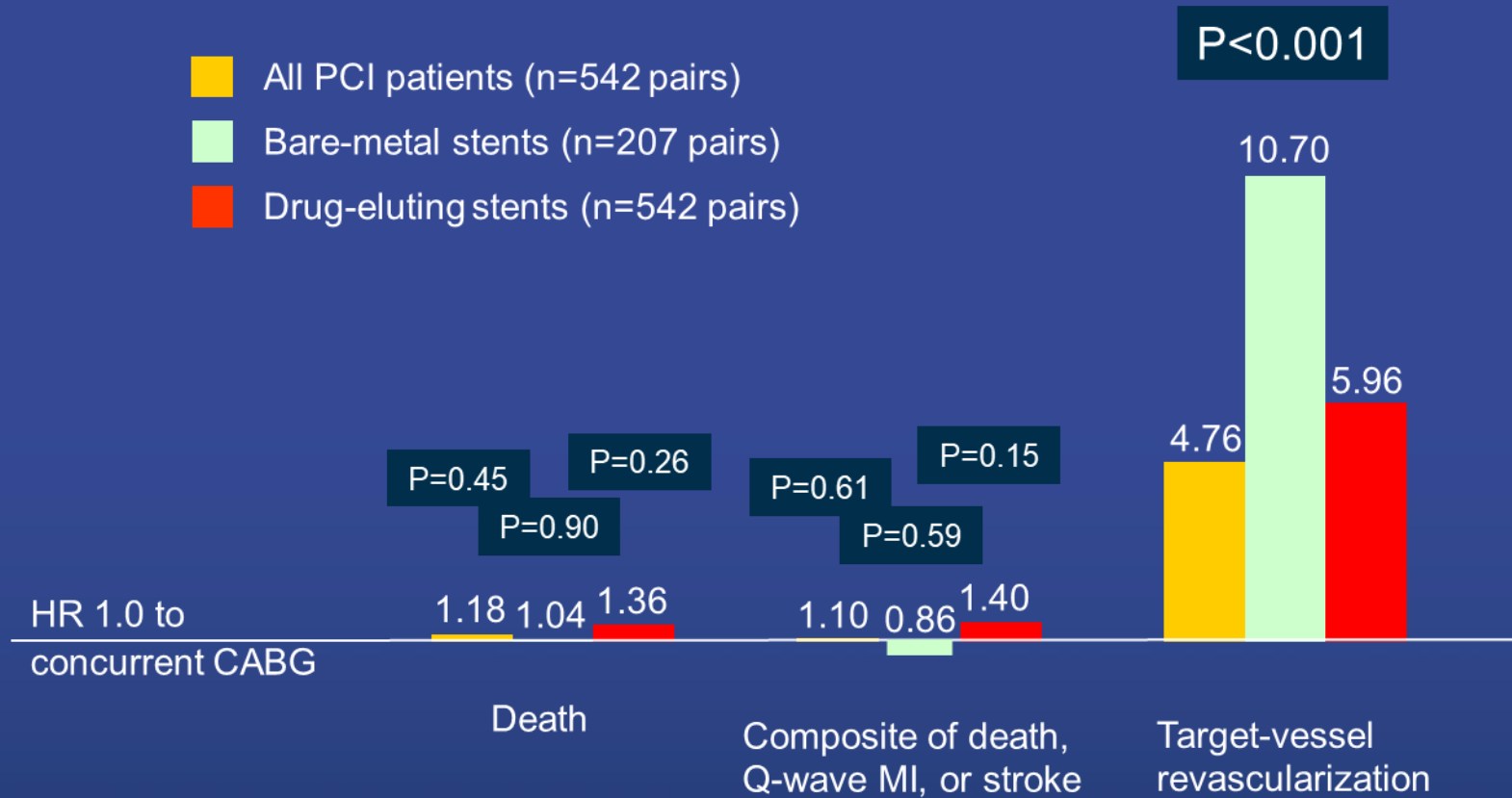

MAIN COMPARE Registry, 5-Year

Adjusted HR by Use of IPTW Method

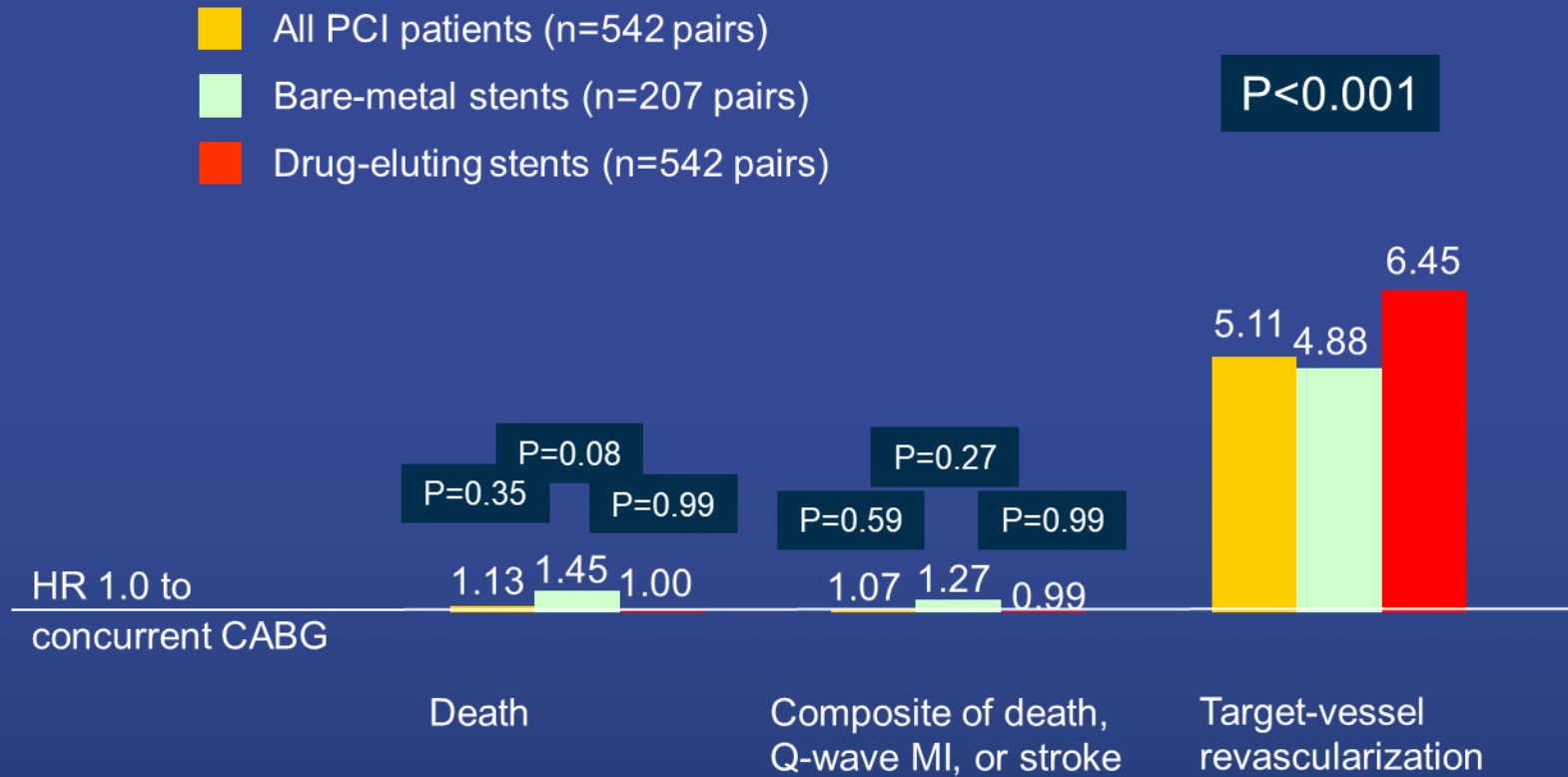

PCI vs. CABG for Left Main Disease

10-year outcomes of the **MAIN-COMPARE** registry : All-cause death

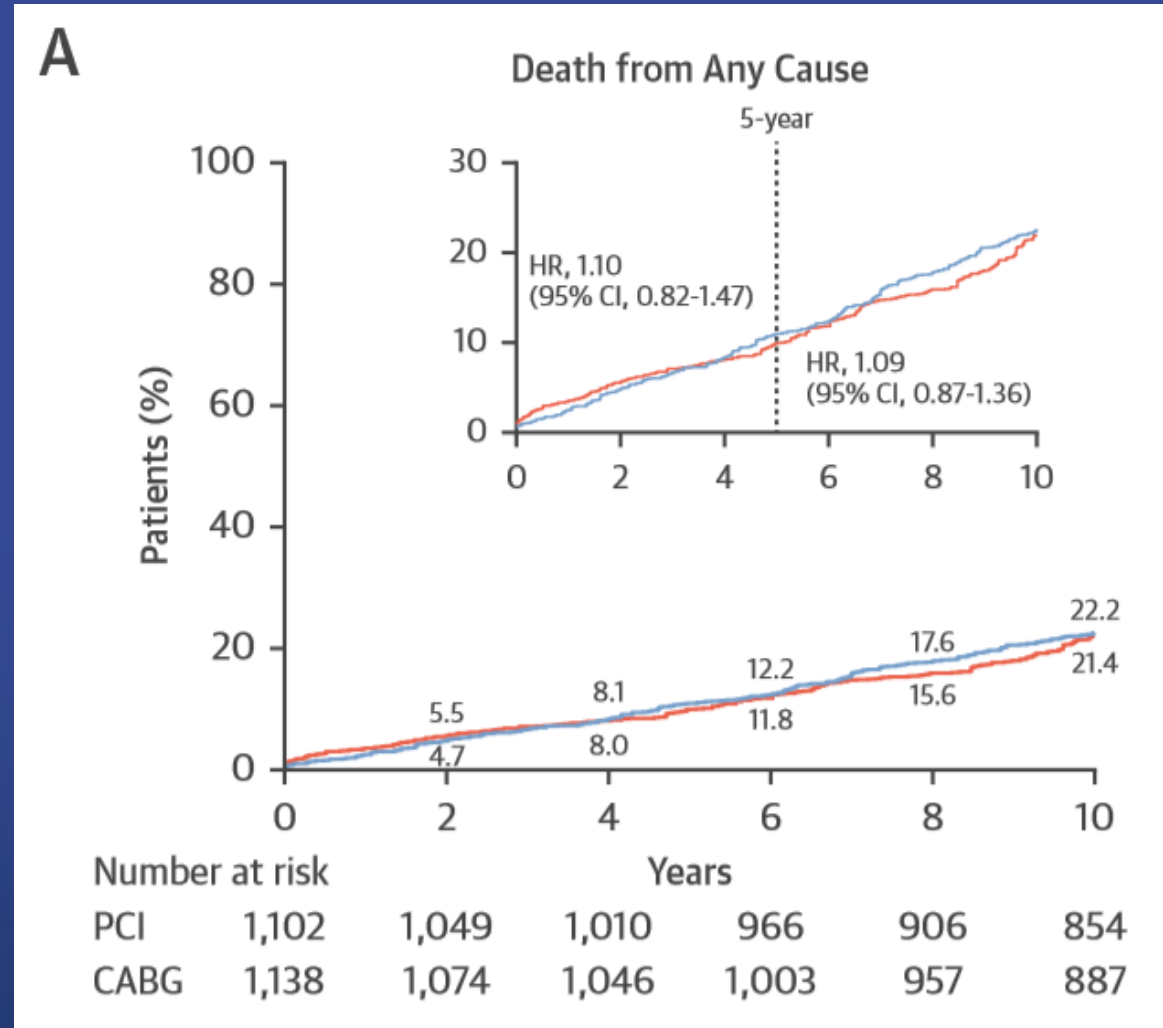

PCI vs. CABG for Left Main Disease

10-year outcomes of the **MAIN-COMPARE** registry : Death, Q-wave MI, or stroke

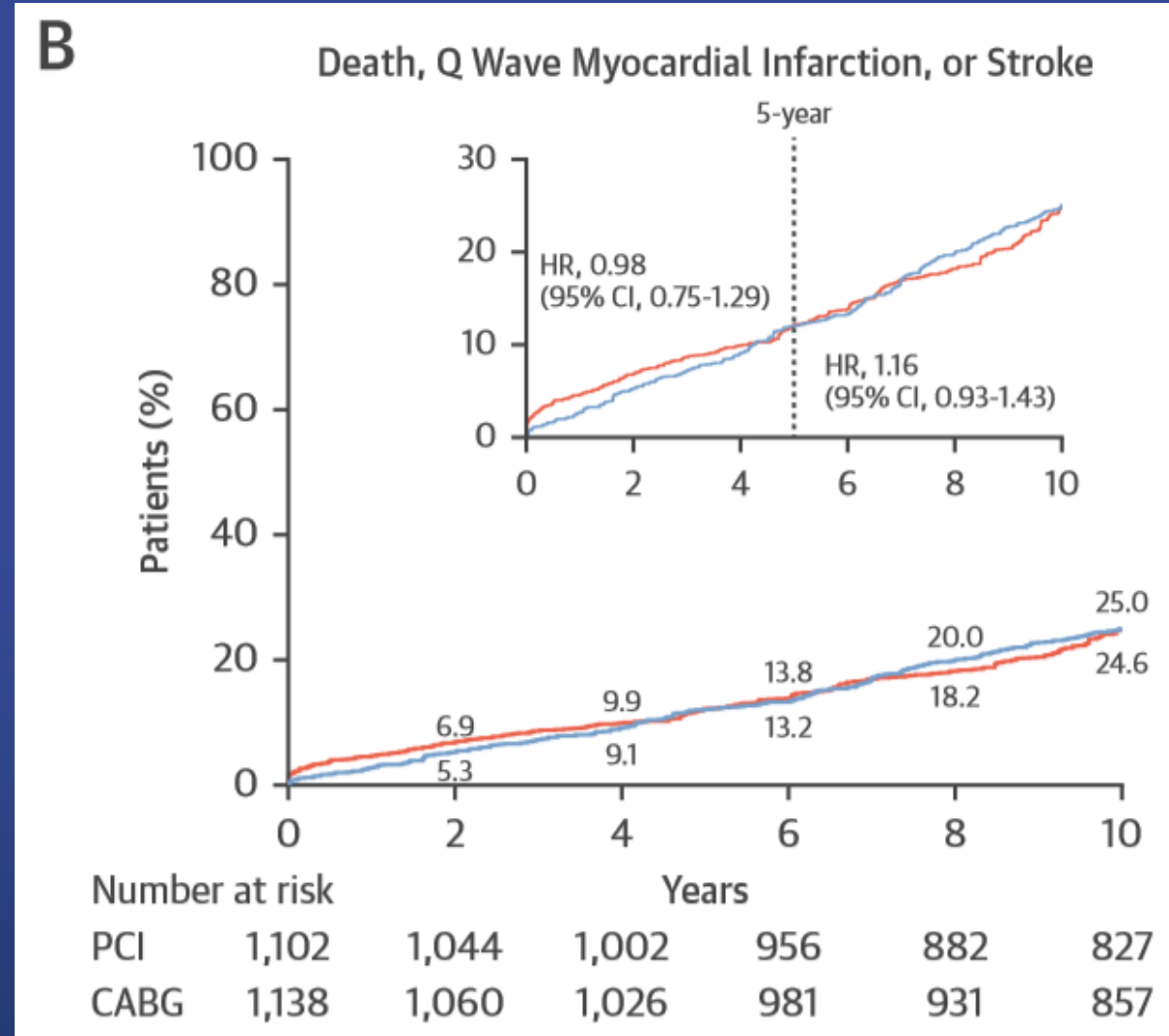

PCI vs. CABG for Left Main Disease

10-year outcomes of the **MAIN-COMPARE** registry : Target-Vessel Revascularization

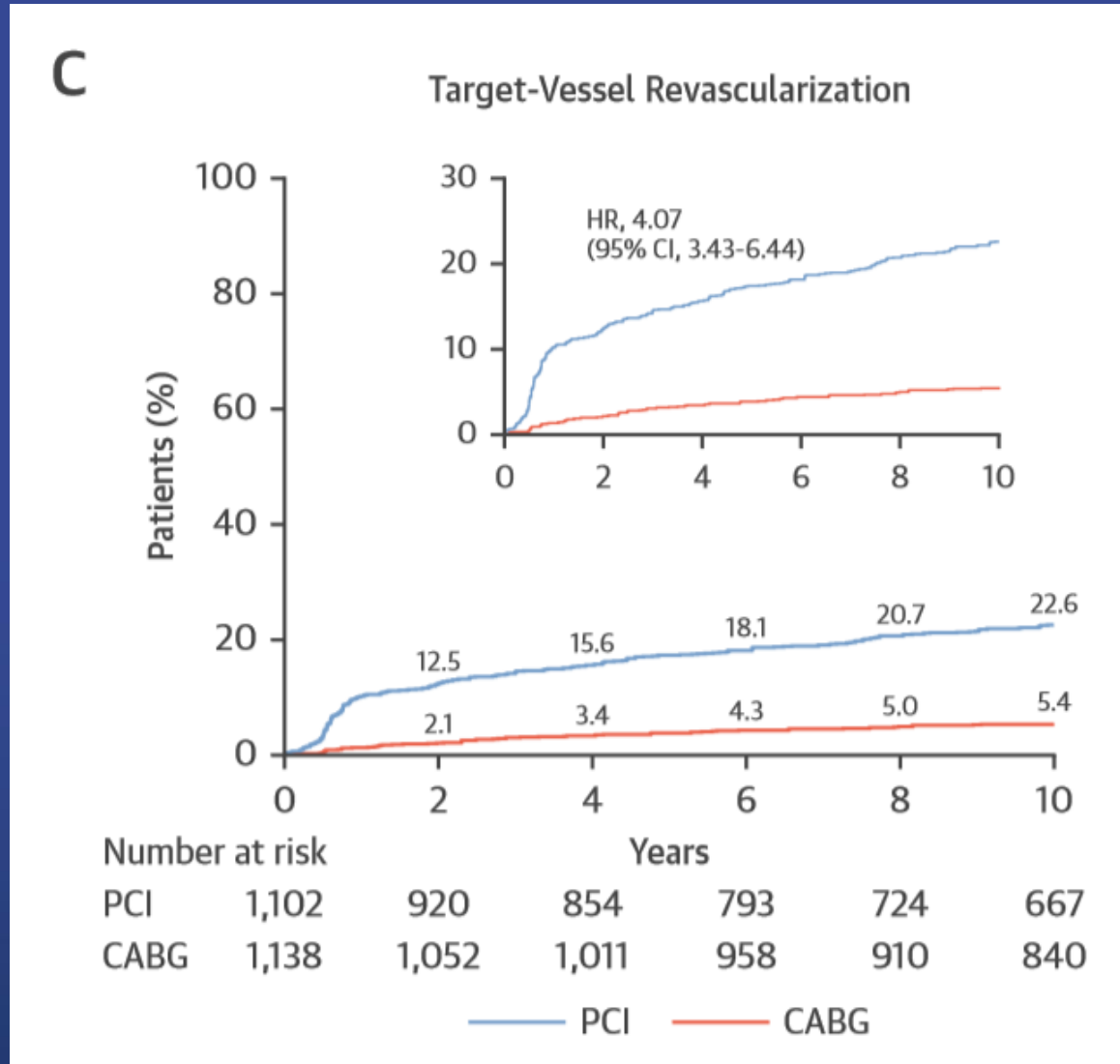

Park et al. J Am Coll Cardiol. 2018;72:2813-22

Hazard Ratios for Clinical Outcomes Before and After 5-Year of Follow-up

Outcome	Overall Cohort		Wave 1* (BMS)		Wave 2* (DES)	
	Hazard Ratio† (95% CI)	P value	Hazard Ratio† (95% CI)	P value	Hazard Ratio† (95% CI)	P value
<i>Analyses with IPTW</i>	N = 2240 patients (PCI 1102, CABG 1138)		N = 766 patients (BMS 318, CABG 448)		N = 1474 patients (DES 784, CABG 690)	
Death		0.64		0.05		0.15
0~5 years	1.10 (0.82–1.47)	0.53	1.65 (0.91–2.98)	0.10	1.02 (0.71–1.46)	0.91
>5 years	1.09 (0.87–1.36)	0.48	0.68 (0.46–1.02)	0.06	1.35 (1.00–1.81)	0.05
Composite outcome (death, Q-wave MI or stroke)		0.43		0.06		0.03
0~5 years	0.98 (0.75–1.29)	0.91	1.46 (0.84–2.53)	0.18	0.91 (0.66–1.27)	0.59
>5 years	1.16 (0.93–1.43)	0.19	0.67 (0.46–1.00)	0.05	1.46 (1.10–1.94)	0.009
TVR, All period	4.07 (3.43–6.44)	<0.001	4.45 (2.81–7.05)	<0.001	5.82 (3.77–9.01)	<0.001

PCI vs. CABG for Left Main Disease

Extended Follow-Up of the **PRECOMBAT** trial : Primary composite outcome

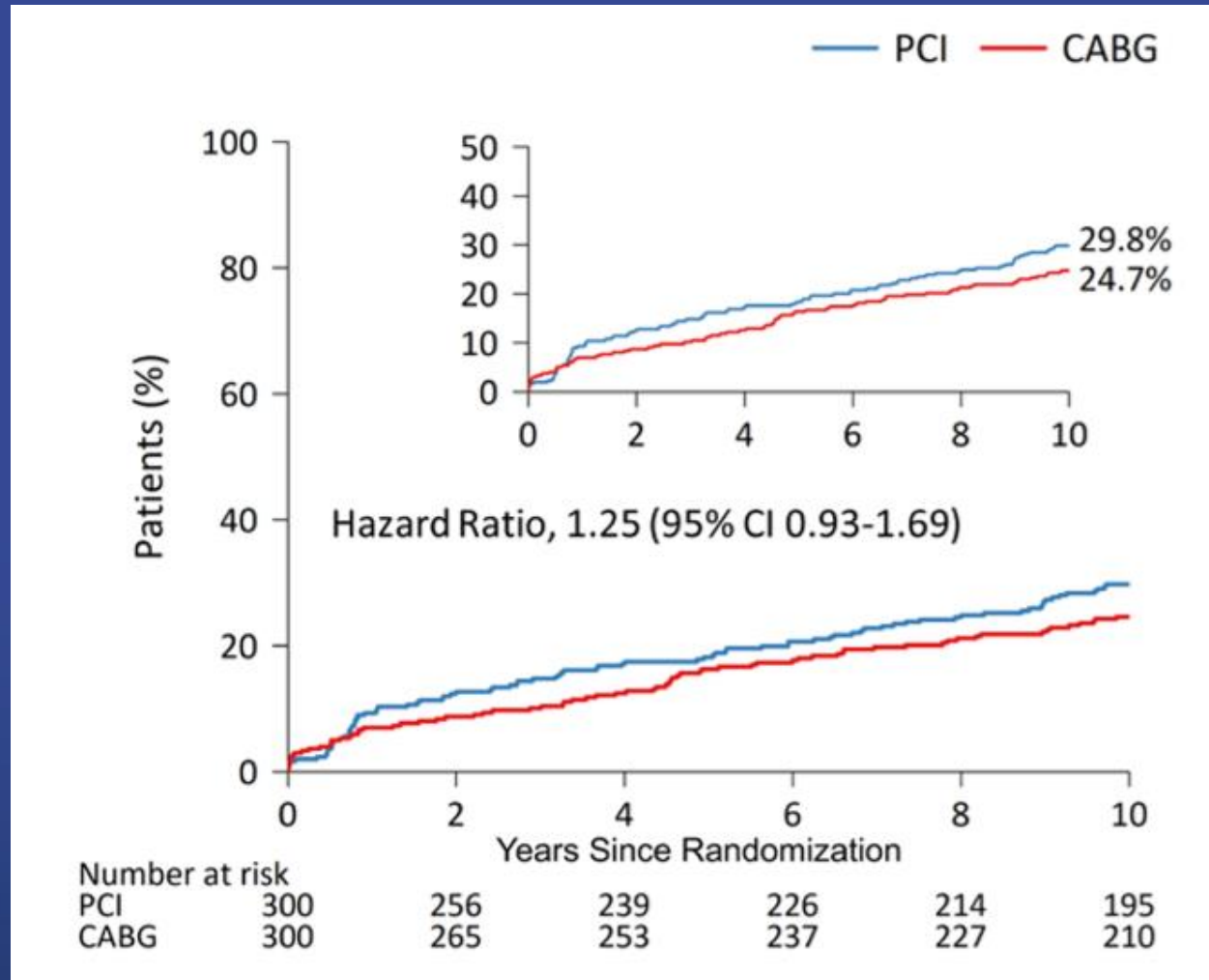

PCI vs. CABG for Left Main Disease

Extended Follow-Up of the [PRECOMBAT](#) trial : Death, MI, or Stroke

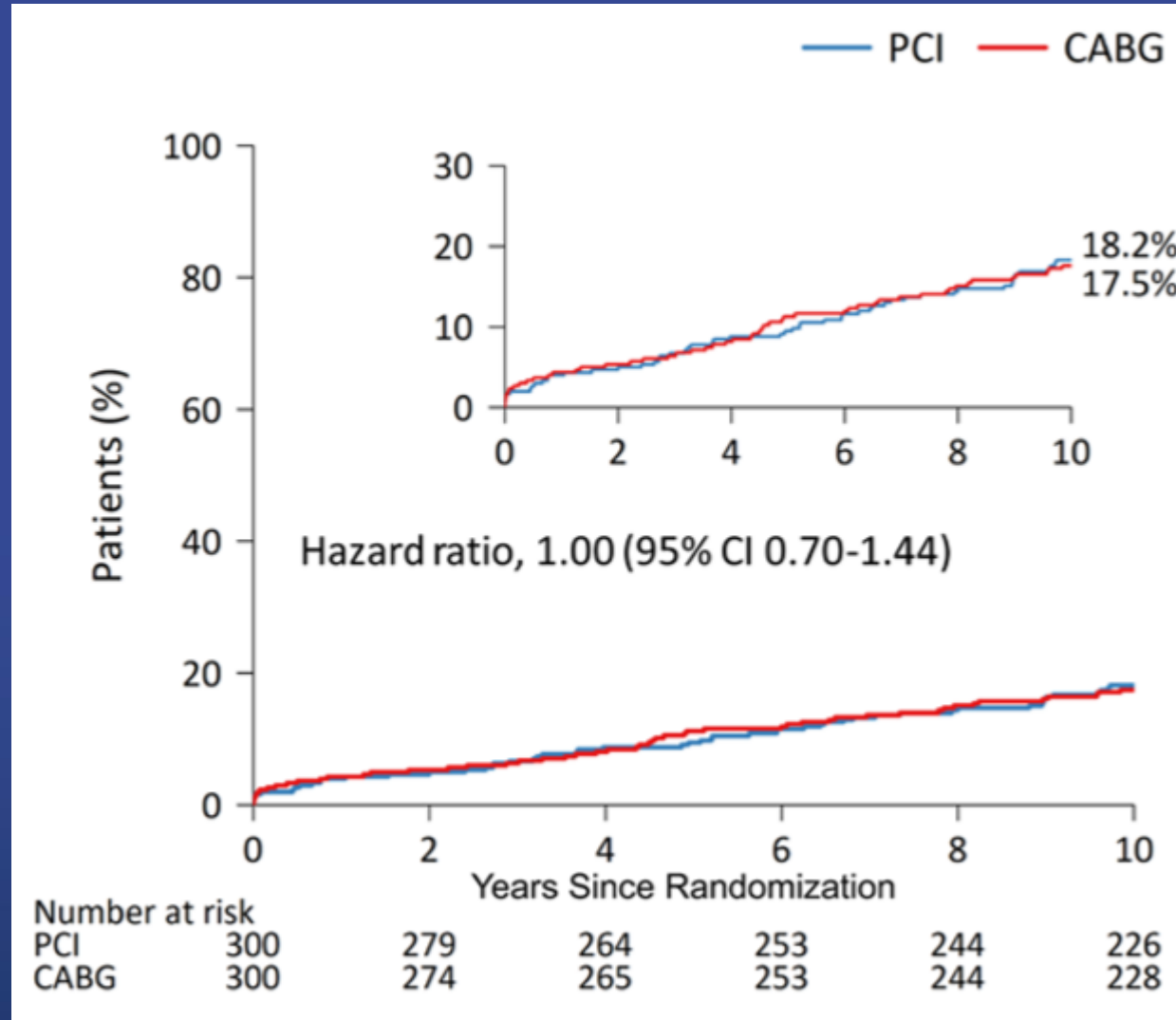

PCI vs. CABG for Left Main Disease

Extended Follow-Up of the [PRECOMBAT](#) trial : All-cause Death

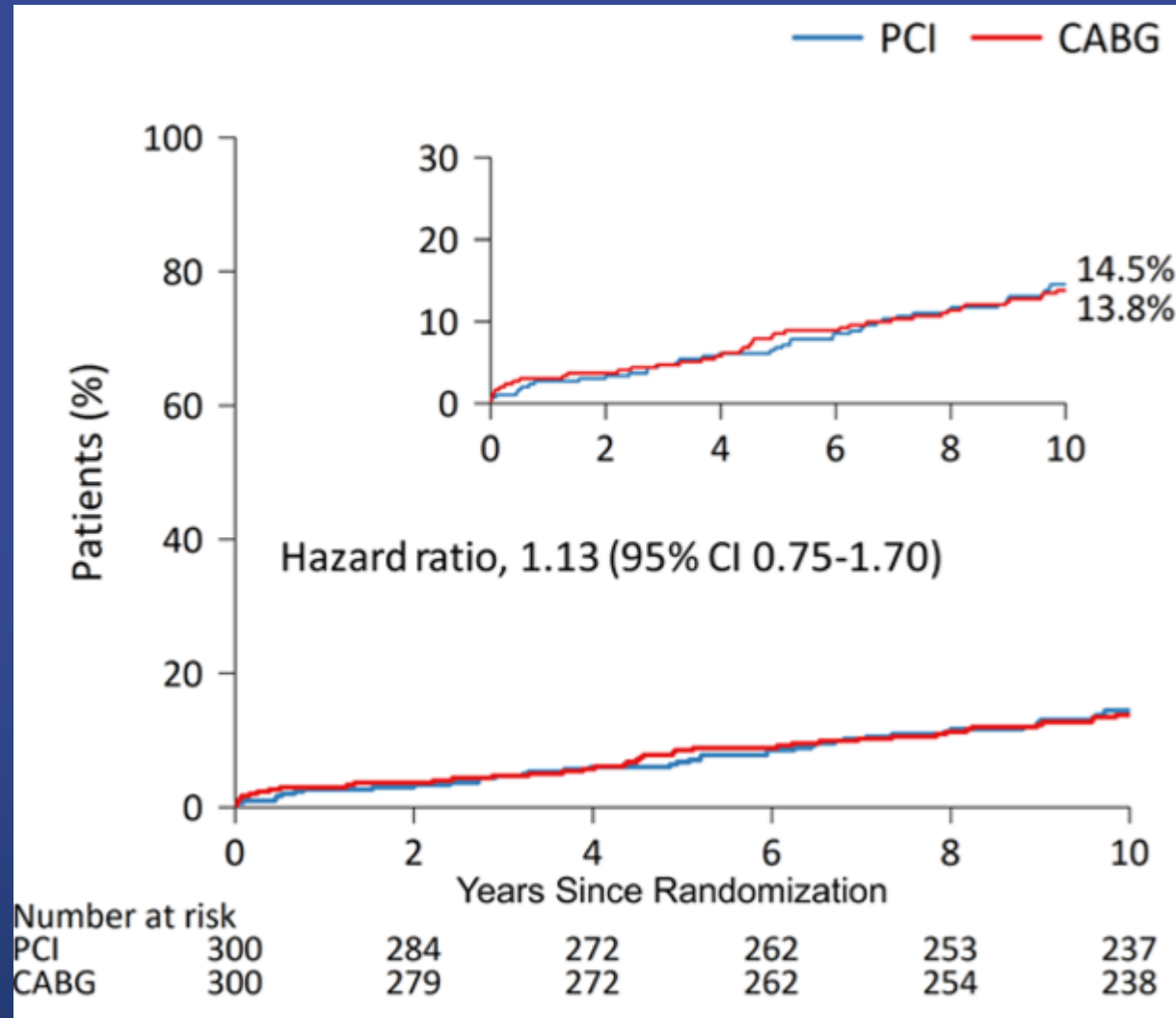

PCI vs. CABG for Left Main Disease

Extended Follow-Up of the [PRECOMBAT](#) trial : Target-Vessel revascularization

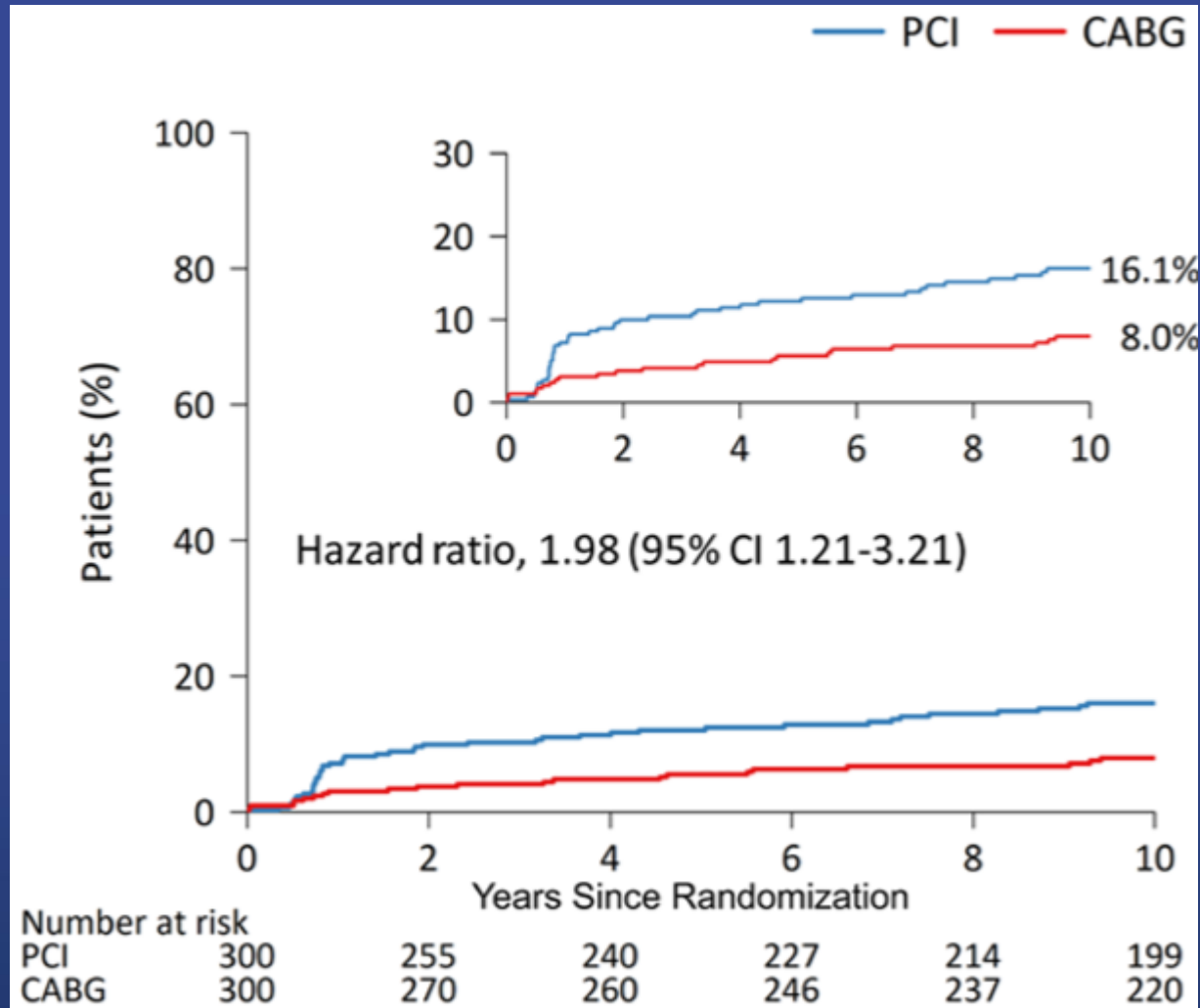

PCI vs. CABG for Left Main Disease

Extended Follow-Up of the **PRECOMBAT** trial

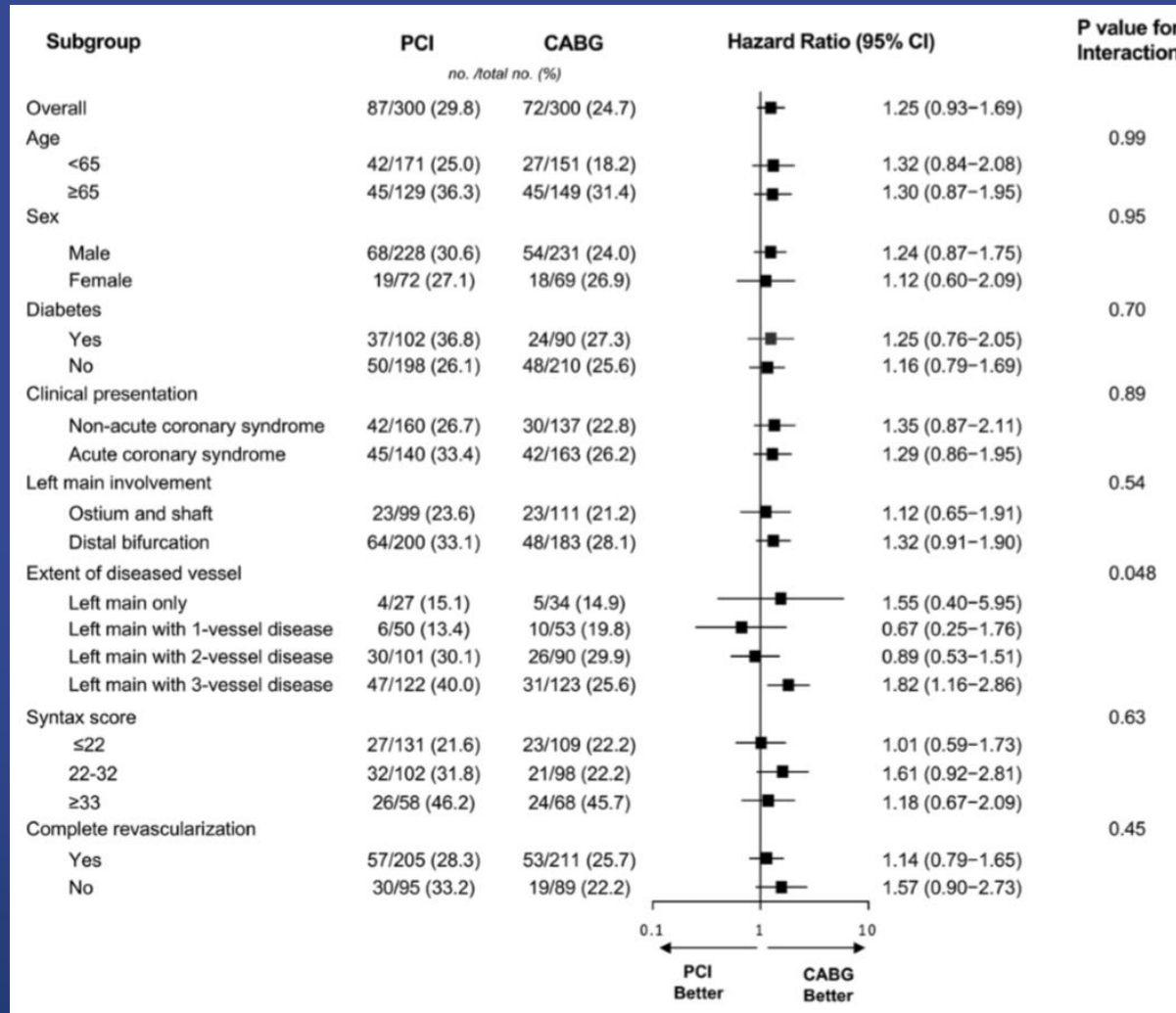

PCI vs. CABG for Left Main Disease

Individual patient data meta-analysis : SYNTAX, PRECOMBAT, NOBLE, EXCEL
all-cause death (0-5Yr)

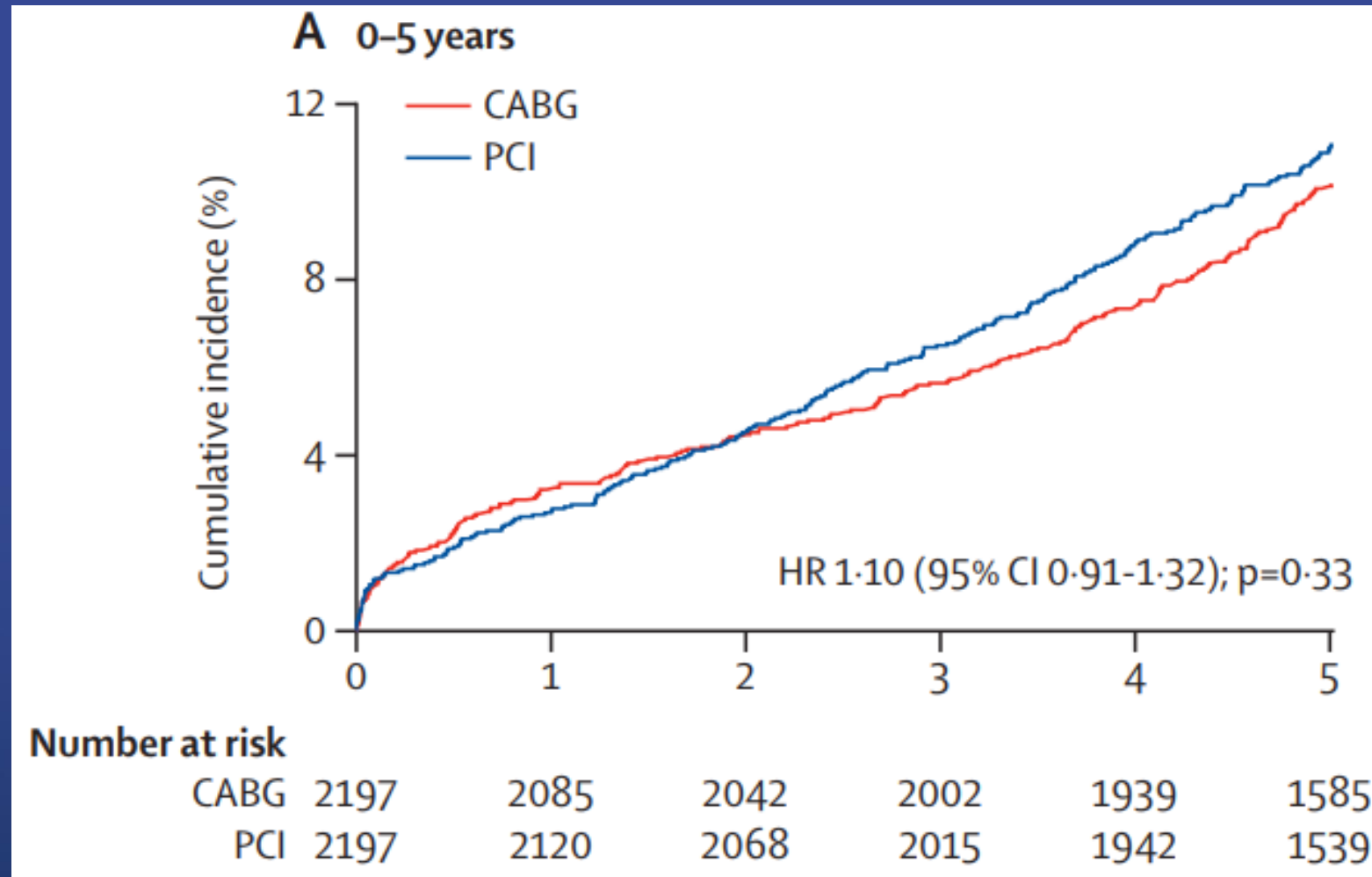

PCI vs. CABG for Left Main Disease

Individual patient data meta-analysis : SYNTAX, PRECOMBAT, NOBLE, EXCEL
all-cause death (0-1Yr)

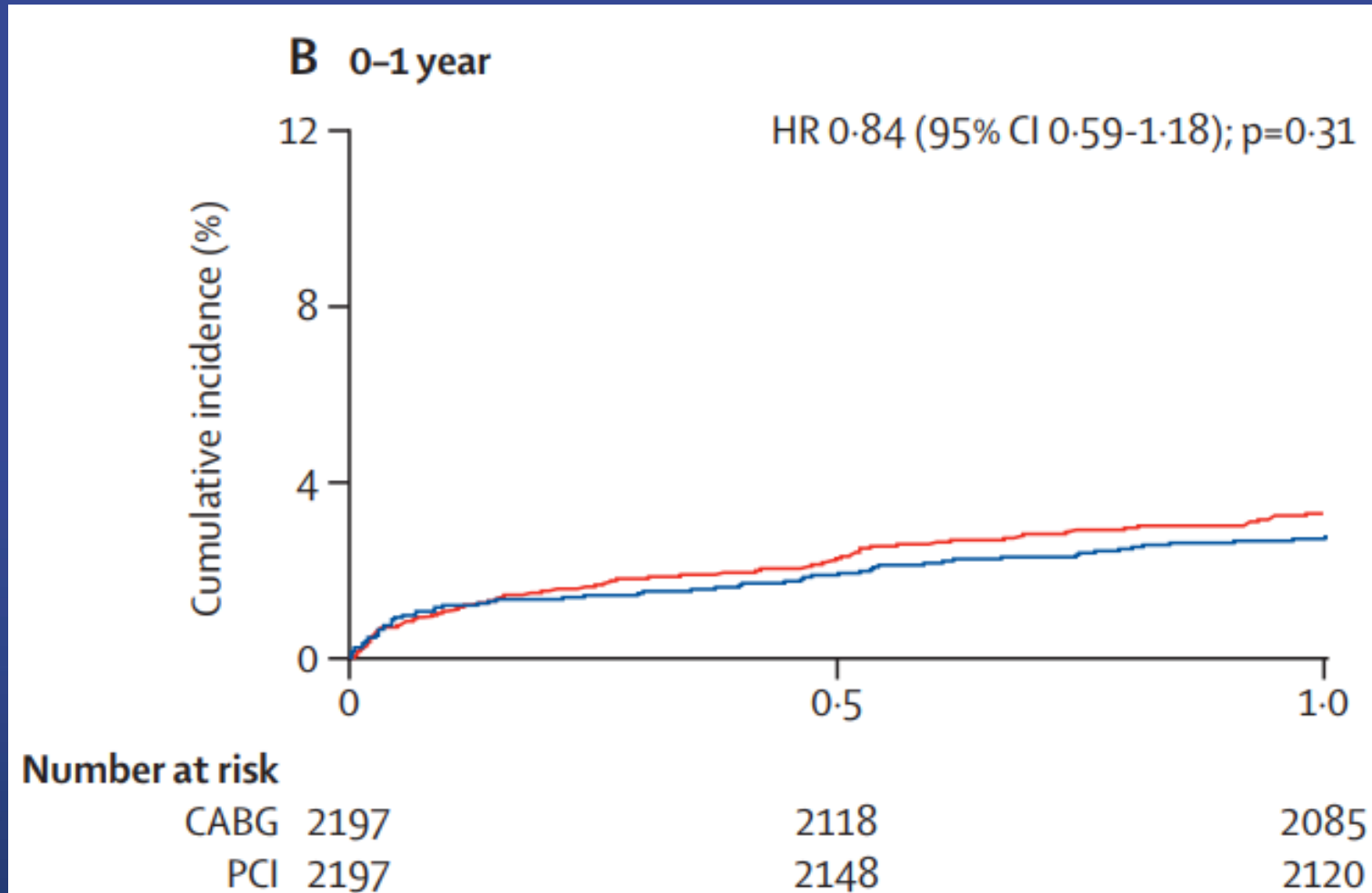

PCI vs. CABG for Left Main Disease

Individual patient data meta-analysis : SYNTAX, PRECOMBAT, NOBLE, EXCEL
all-cause death (1-5Yr)

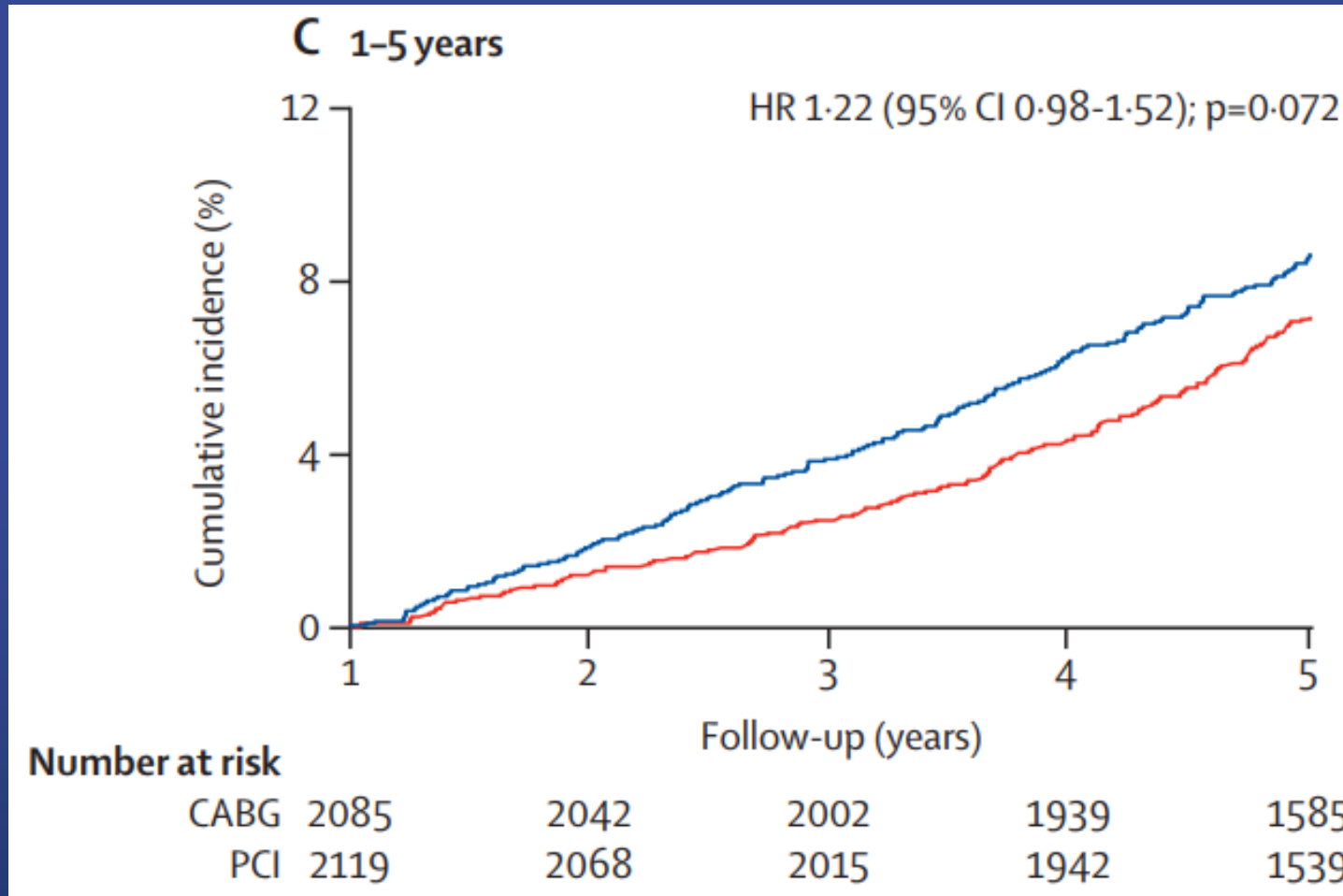

PCI vs. CABG for Left Main Disease

Individual patient data meta-analysis : SYNTAX, PRECOMBAT, NOBLE, EXCEL

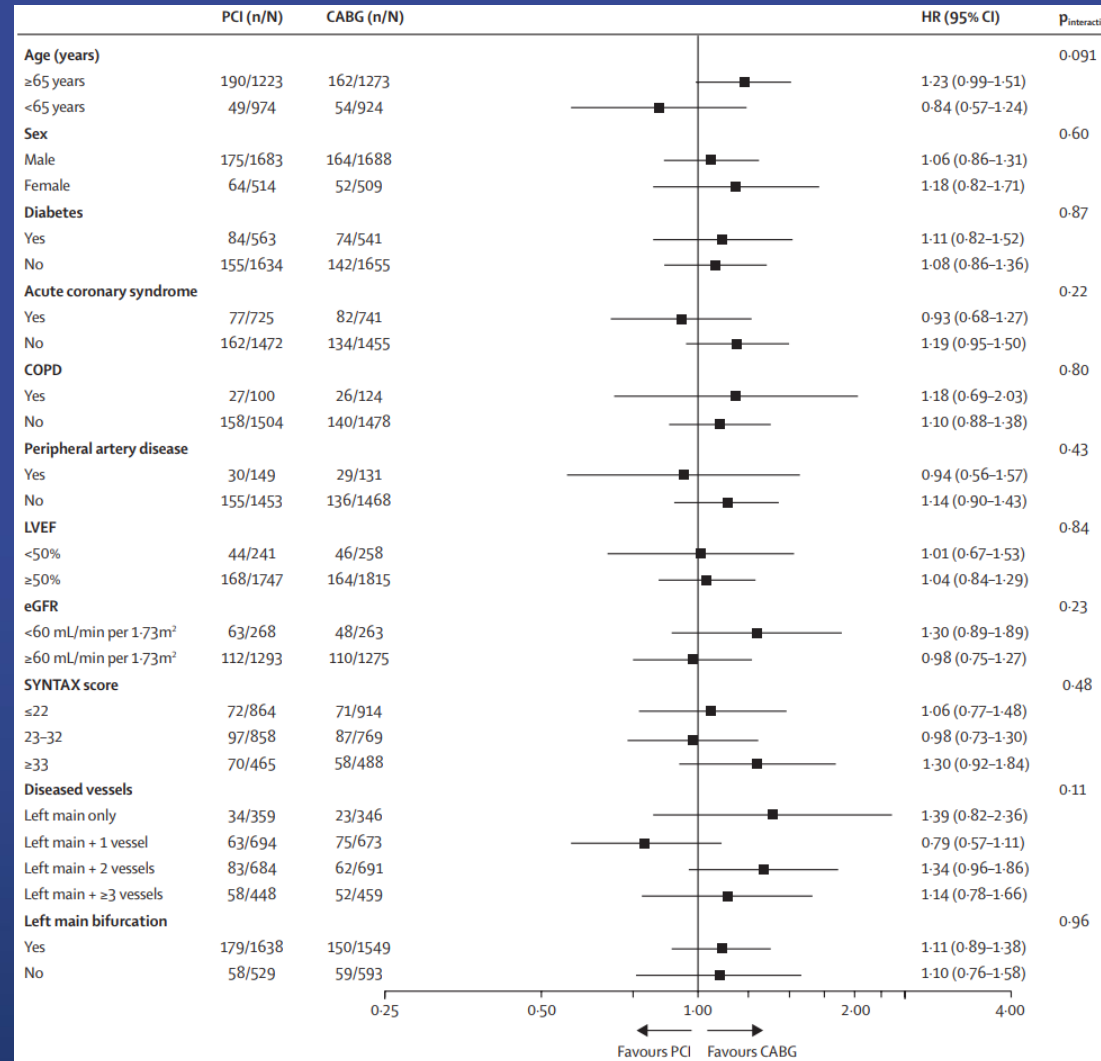

Sabatine et al. Lancet 2021;398:2247-57

LM : DES vs. DES

ISAR-LEFT MAIN 2

ZES vs. EES

The primary outcome: all-cause death, MI, and TLR

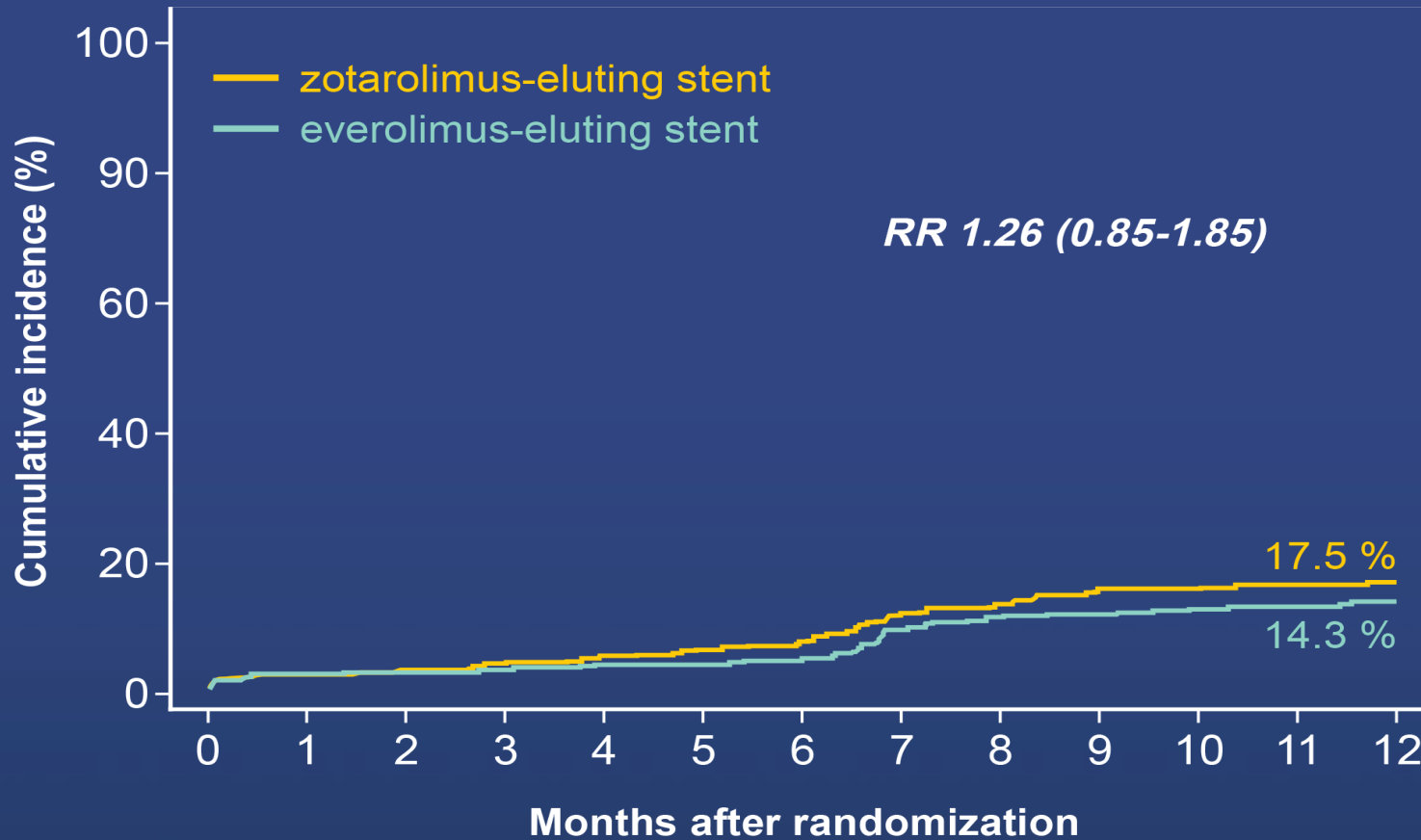

PRECOMBAT-2 Study

EES vs. SES

Primary end point: Major adverse cardiac or cerebrovascular event

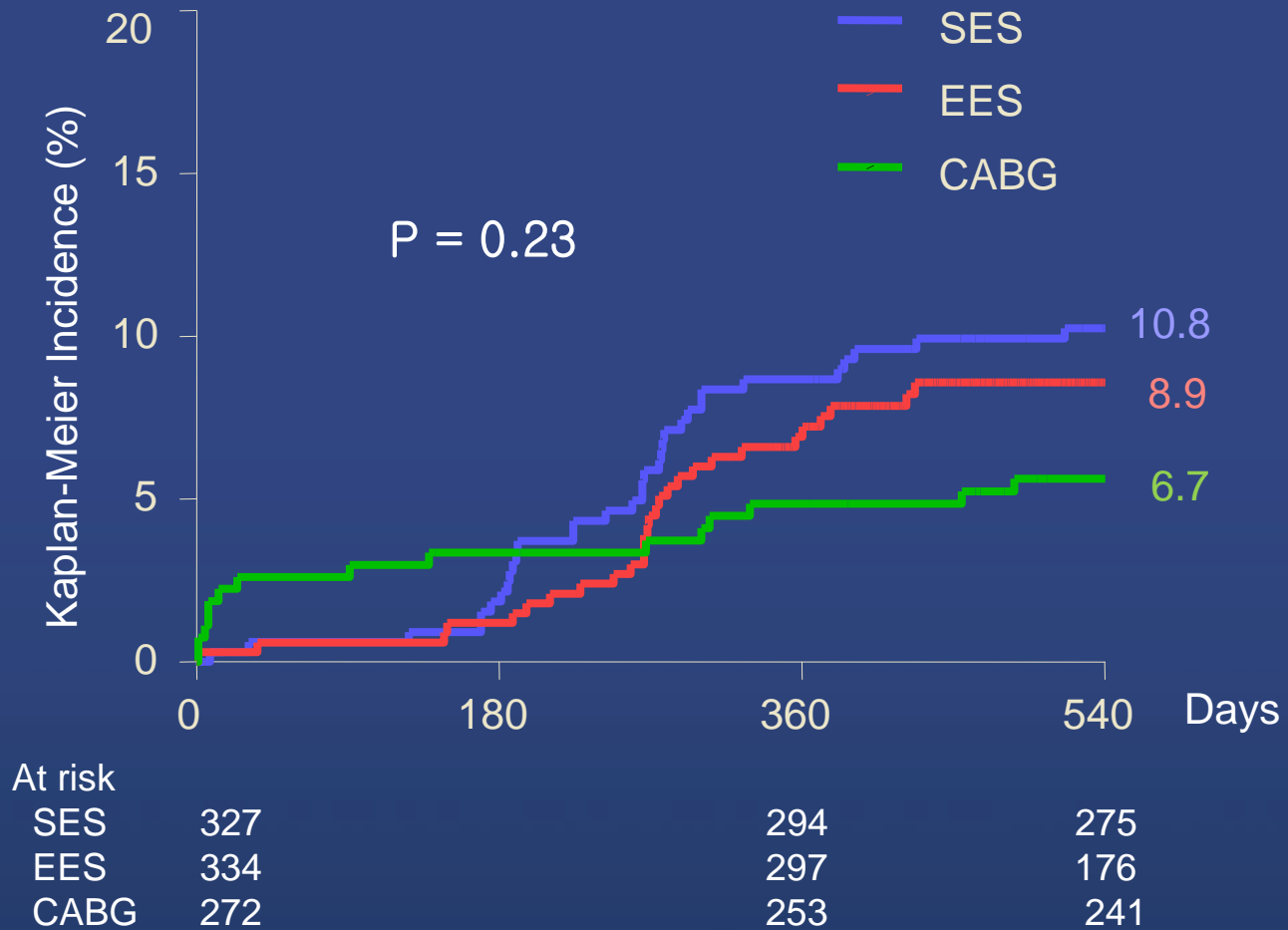

The ULMD Florence registry

EES vs. PES

MACE: Cardiac death, MI, TVR, or stroke

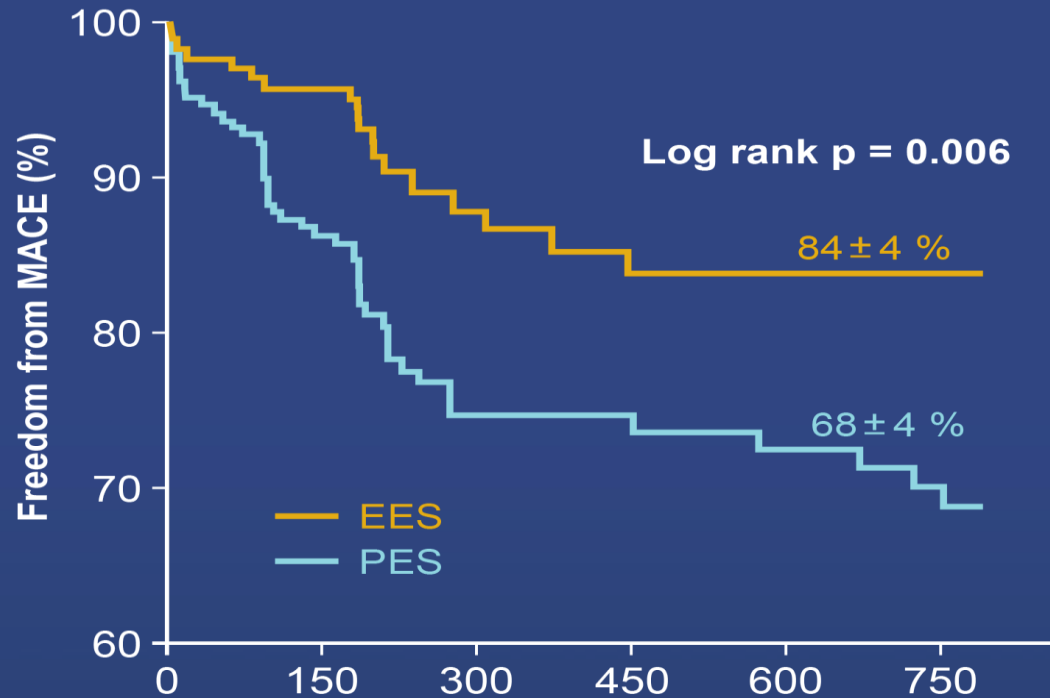

No. at risk

EES

PES

PRECOMBAT-3, 2 Year EES vs. SES

Death, MI, Stroke or Ischemic TVR

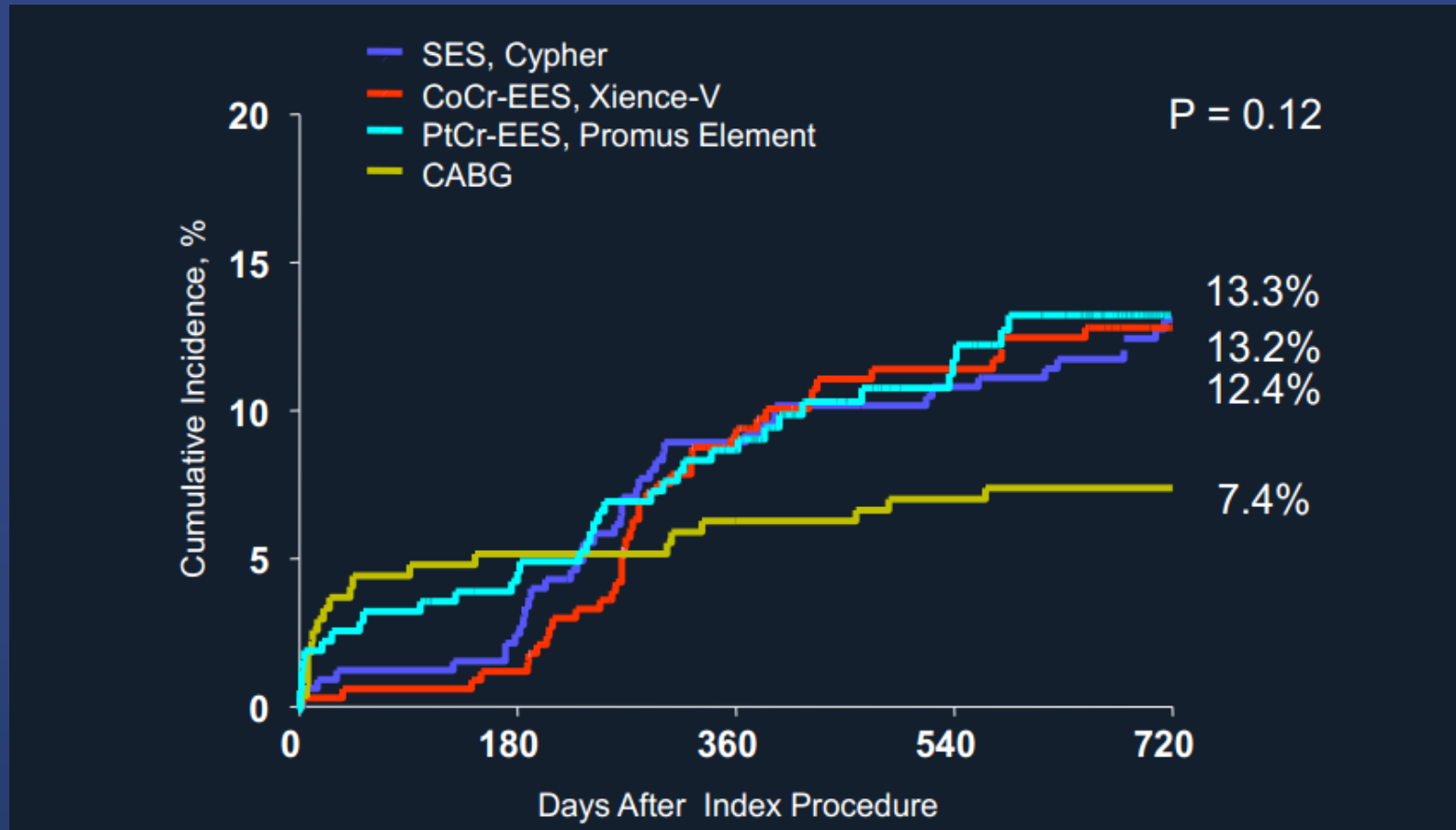

Unpublished Data. 2014

IRIS-MAIN Registry

Comparison of 2nd generation DES

Target vessel failure: Cardiac death, Target vessel MI, or TVR

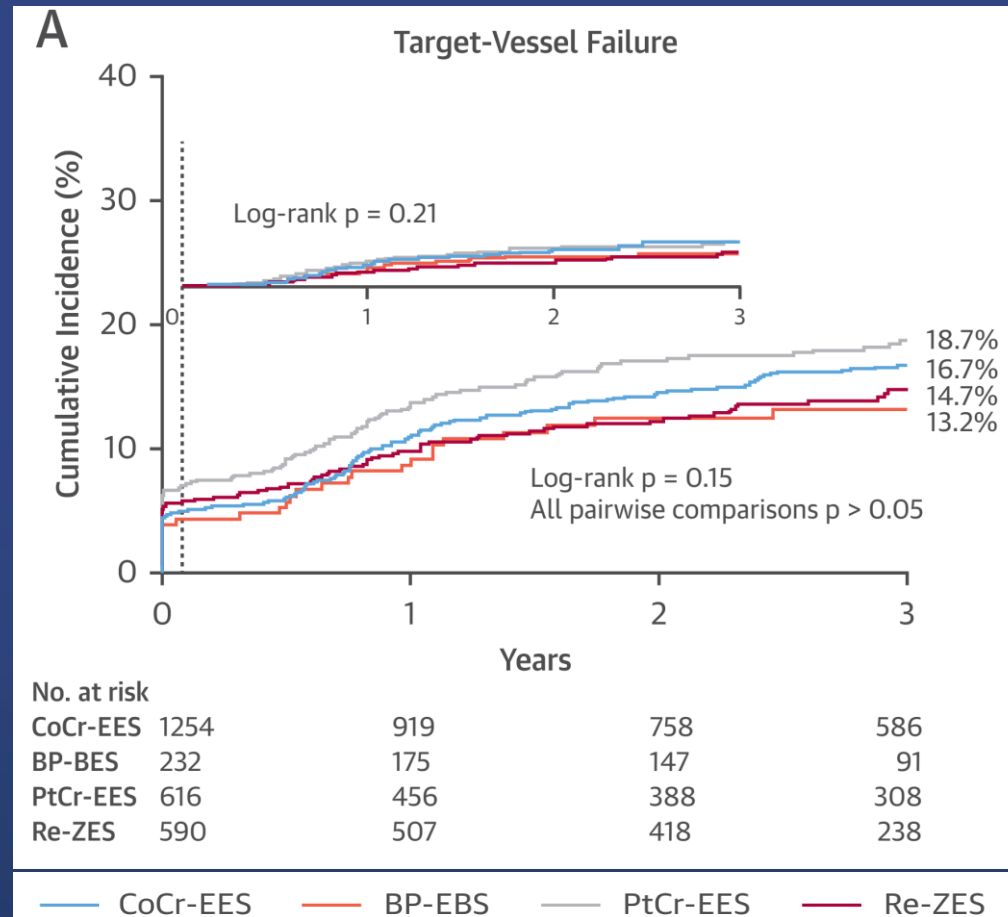

PH Lee et al. JACC 2018;71:832-41.

IRIS-MAIN Registry

Comparison of 2nd generation DES

Target vessel failure: Cardiac death, Target vessel MI, or TVR

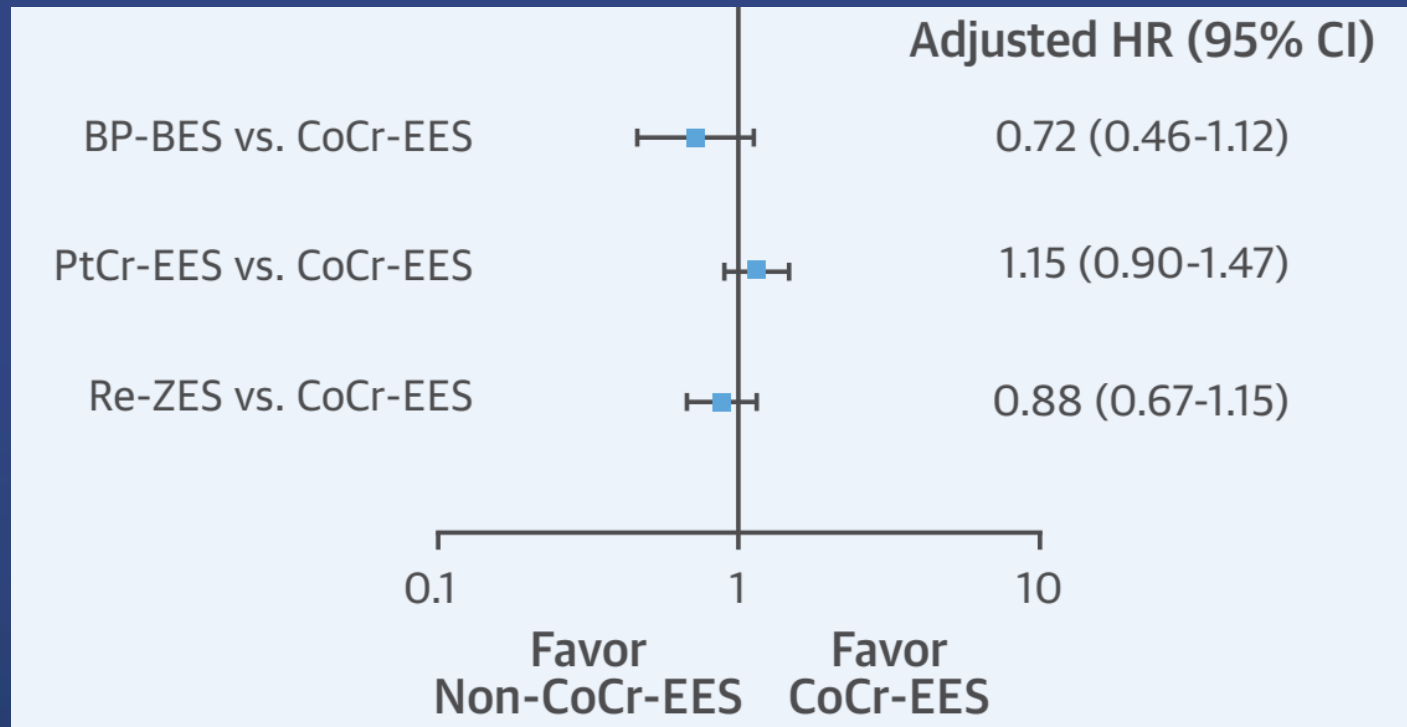

Distal bifurcation
VS.
Ostial / Shaft lesion

Restenosis at 2 year

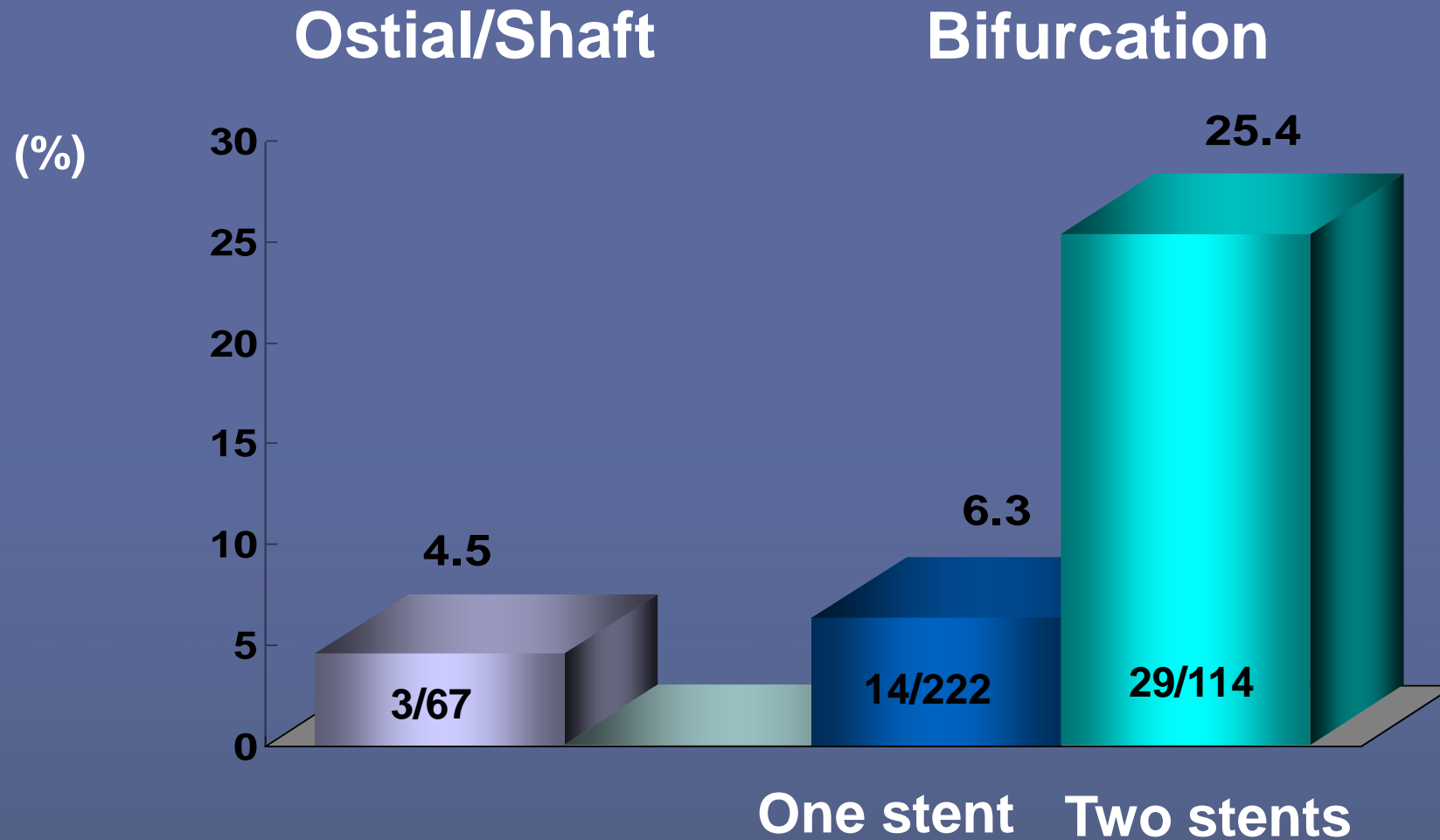

Lesion Specific Approach for LM Bifurcation

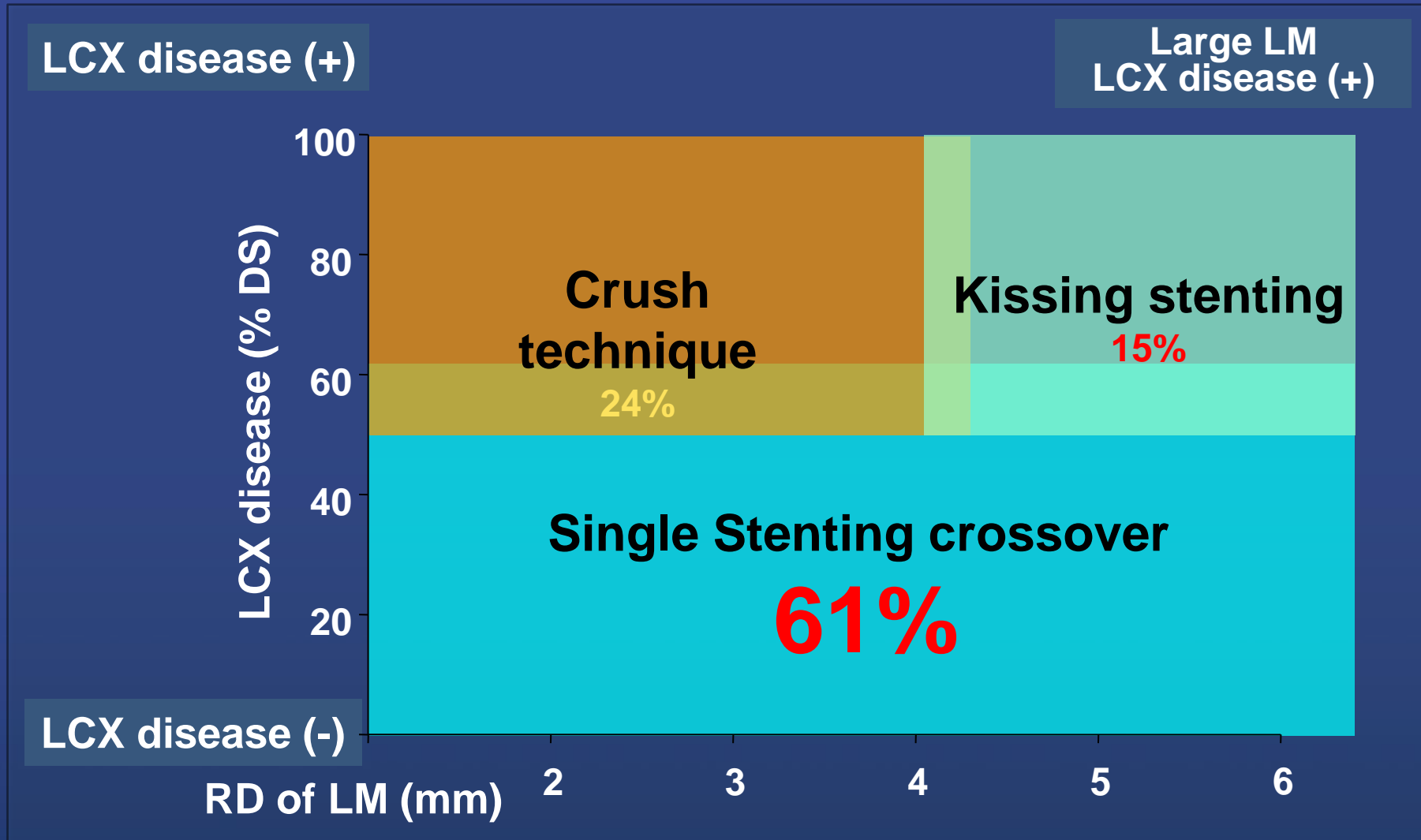

Data from MAIN-COMPARE Registry

Bifurcation vs. Ostial / midshaft lesions

TLR :Treated with DES

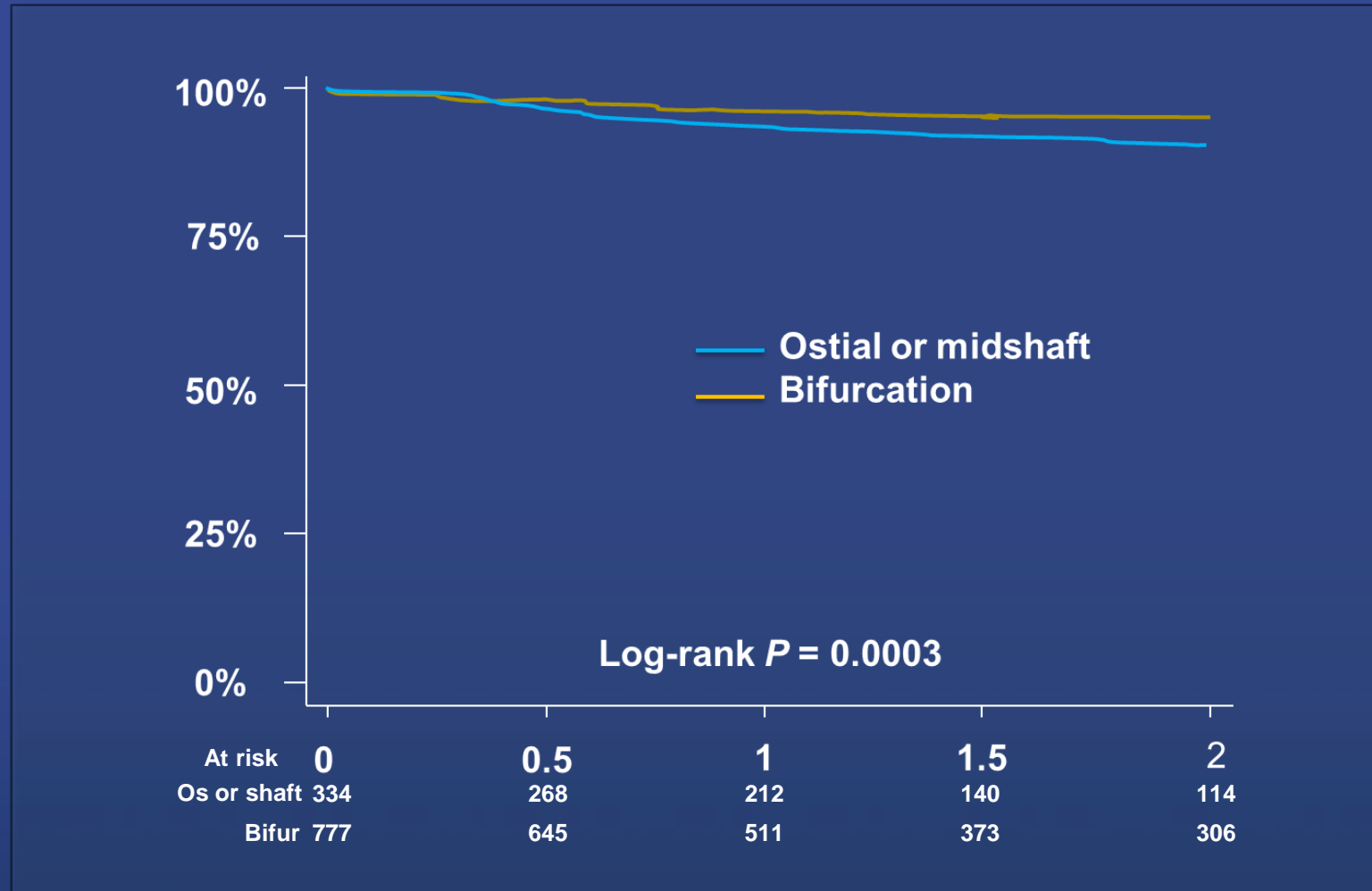

Distal bifurcation vs. Ostial/midshaft

A subgroup of *DELTA* registry - propensity score-matched groups
(Distal bifurcation N=1130, Ostial/mid-shaft N=482)

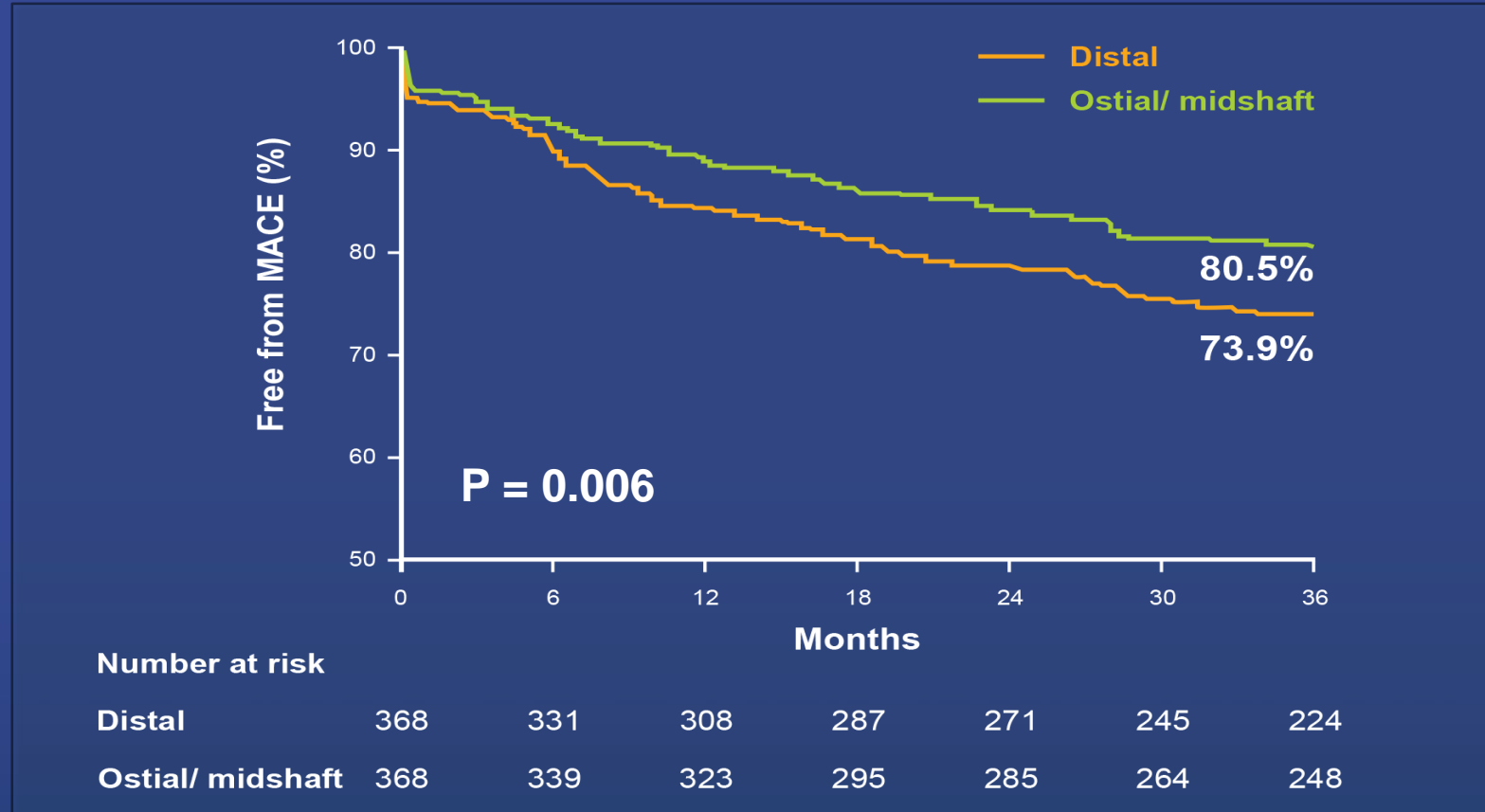

PCI for ostial/mid-shaft lesions was associated with better outcomes than distal bifurcation lesions in LM stenting.

Distal bifurcation vs. Ostial/midshaft

Post-hoc analysis of EXCEL Trial
(Distal bifurcation N=1559, Ostial/mid-shaft N=293)

Primary Endpoint: Death, MI or Stroke

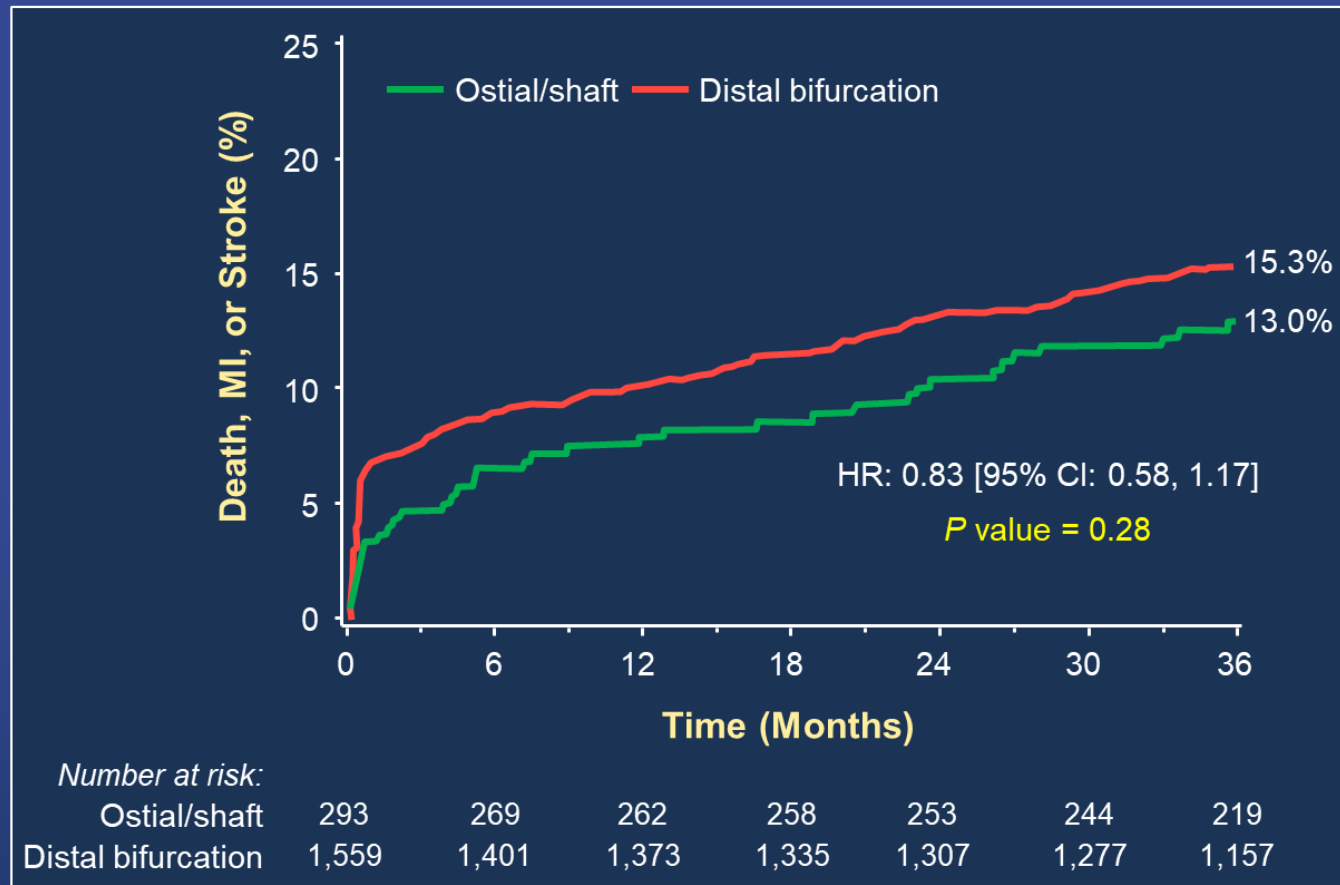

Distal bifurcation vs. Ostial/midshaft

Post-hoc analysis of EXCEL Trial
(Distal bifurcation N=1559, Ostial/mid-shaft N=293)

Ischemia-driven Revascularization

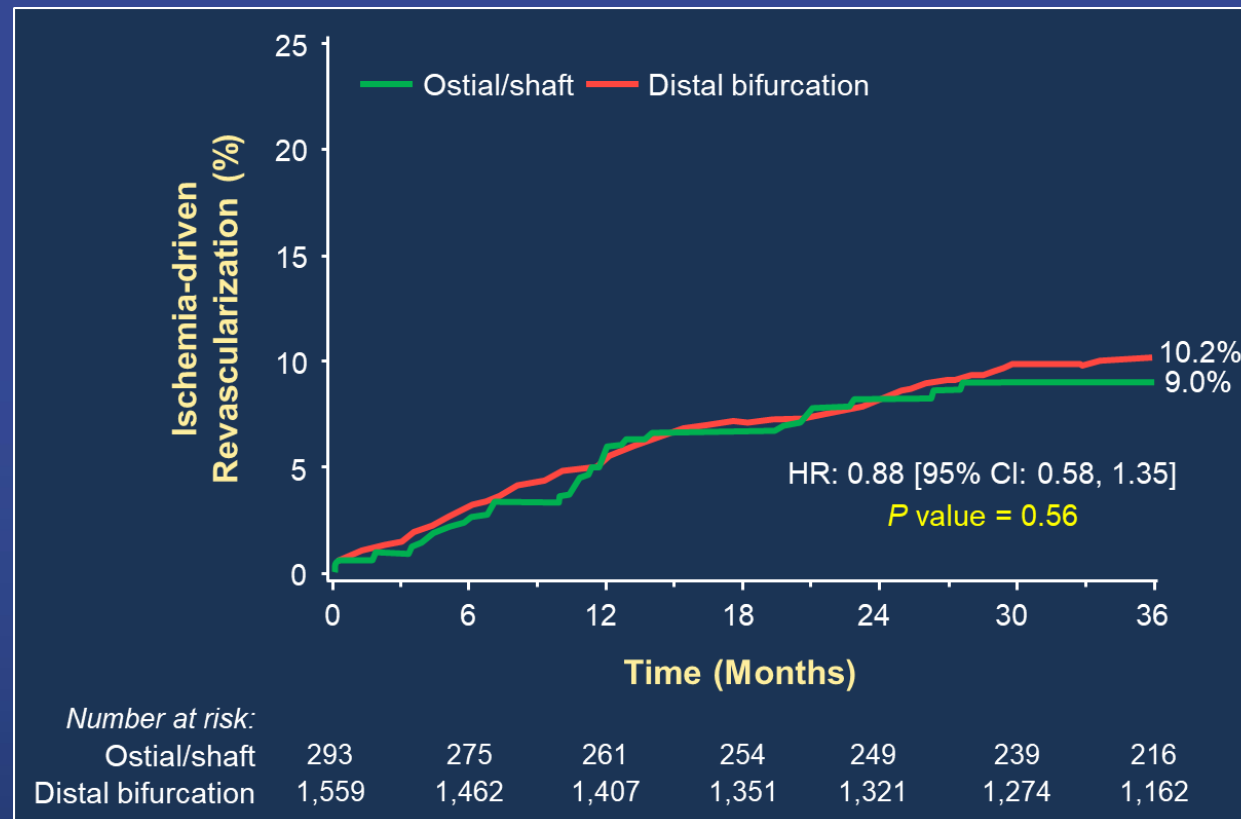

PCI vs. CABG for Ostial/Midshaft LM stenosis

A subgroup of *DELTA* registry (PCI, 482; CABG, 374 patients)

The results of propensity score-matched groups

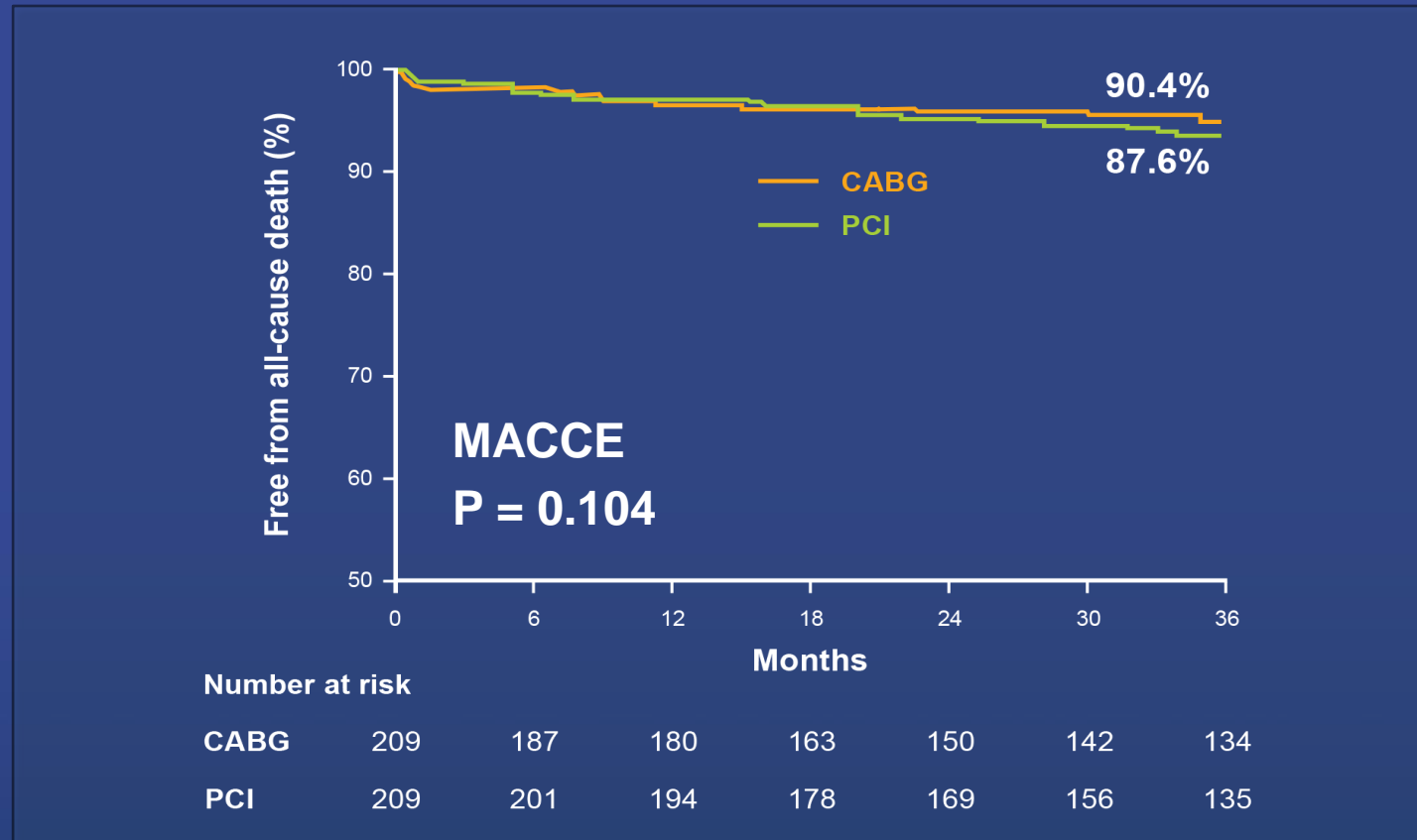

PCI for ostial/midshaft lesions was associated with clinical outcomes comparable to those observed with CABG

DES vs. CABG

for LM Ostial/Shaft & Bifurcation

MAIN-COMPARE registry

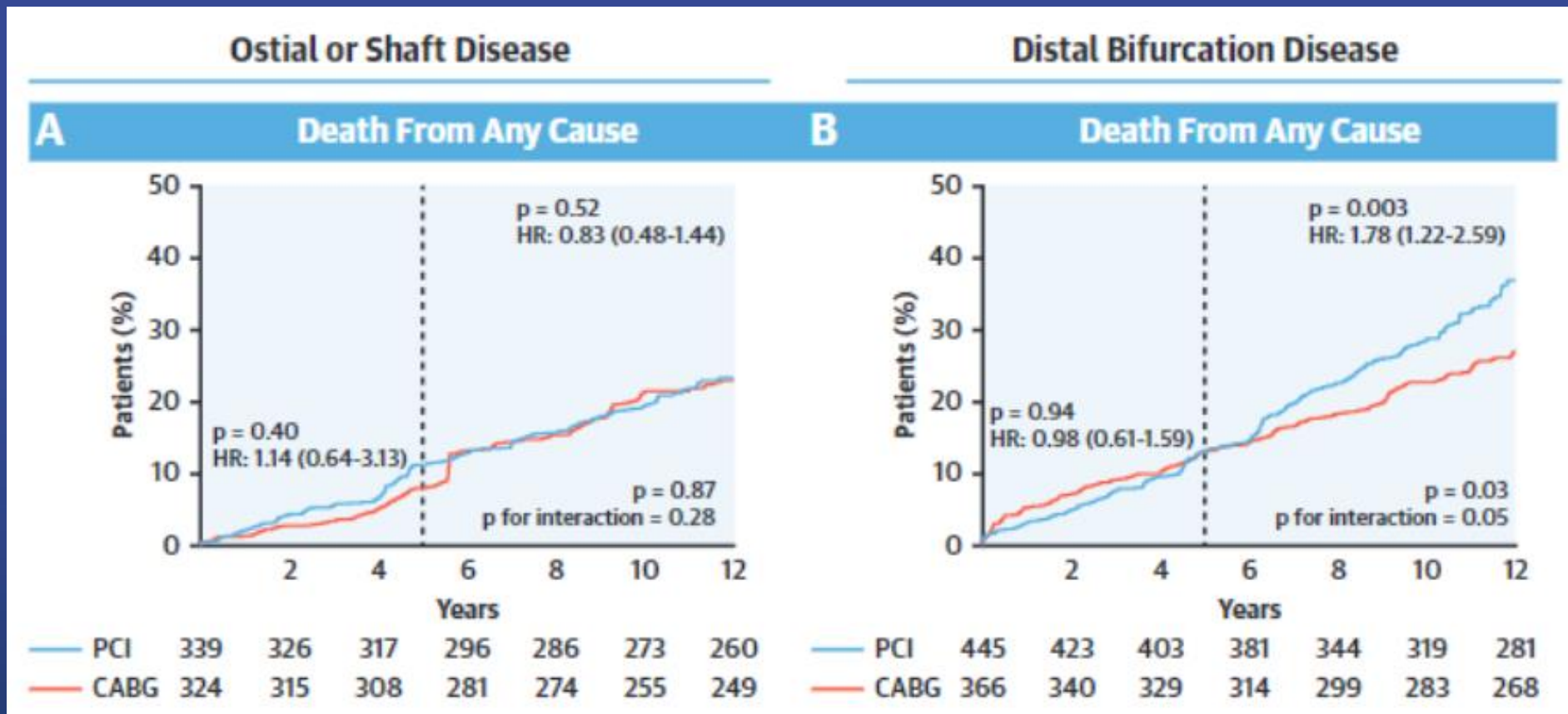

DES vs. CABG

for LM Ostial/Shaft & Bifurcation

MAIN-COMPARE registry

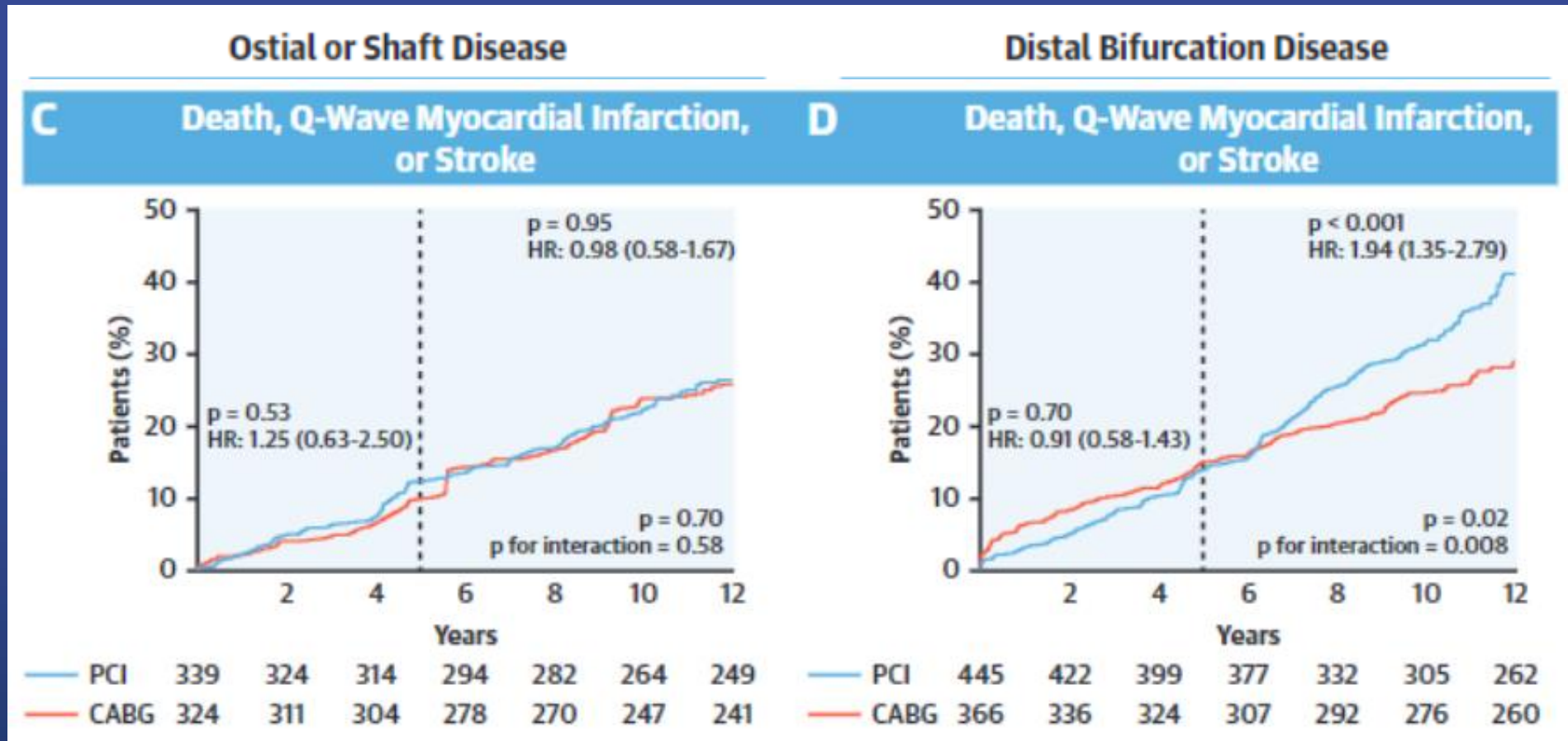

DES vs. CABG for LM Ostial/Shaft & Bifurcation

Ostial or Shaft Disease

Distal Bifurcation Disease

E Target Vessel Revascularization

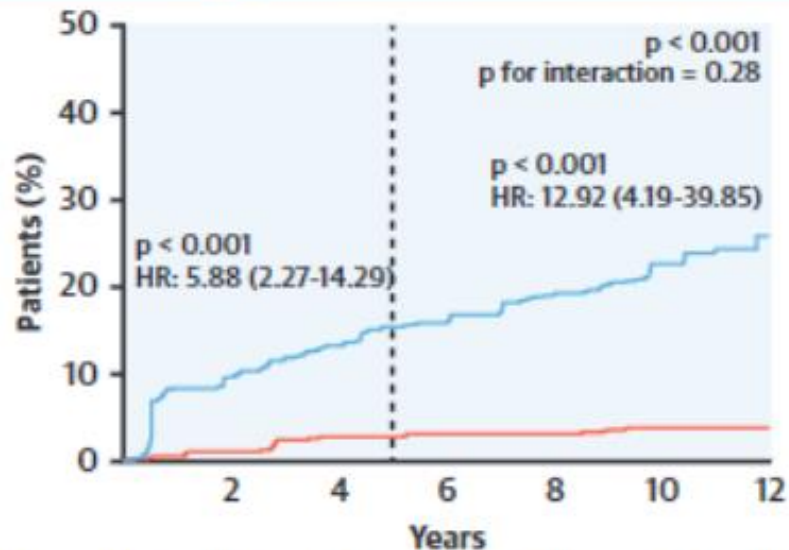

— PCI	339	306	294	285	275	262	251
— CABG	324	320	315	314	314	311	311

		← <5 years >5 years →	
Mortality	:	PCI = CABG	PCI = CABG
Serious events	:	PCI = CABG	PCI = CABG
Revascularization	:	PCI > CABG	PCI > CABG

F Target Vessel Revascularization

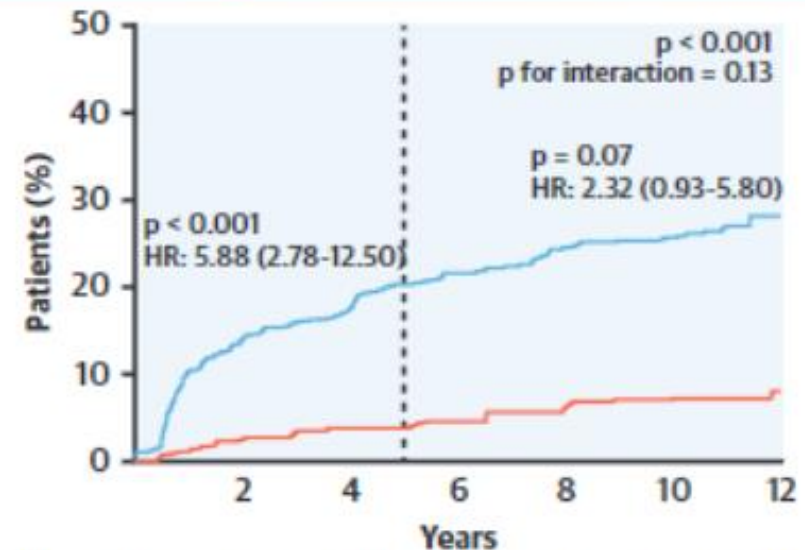

— PCI	445	383	369	349	336	330	320
— CABG	366	357	352	349	344	340	337

		← <5 years >5 years →	
Mortality	:	PCI = CABG	PCI > CABG
Serious events	:	PCI = CABG	PCI > CABG
Revascularization	:	PCI > CABG	PCI > CABG

Distal LM Restenosis

UDLM-ISR subgroup of The CORPAL Registry (N=79)

Simple: POBA or in-stent implantation

Complex: 1 additional stent implantation or 2-stenting technique

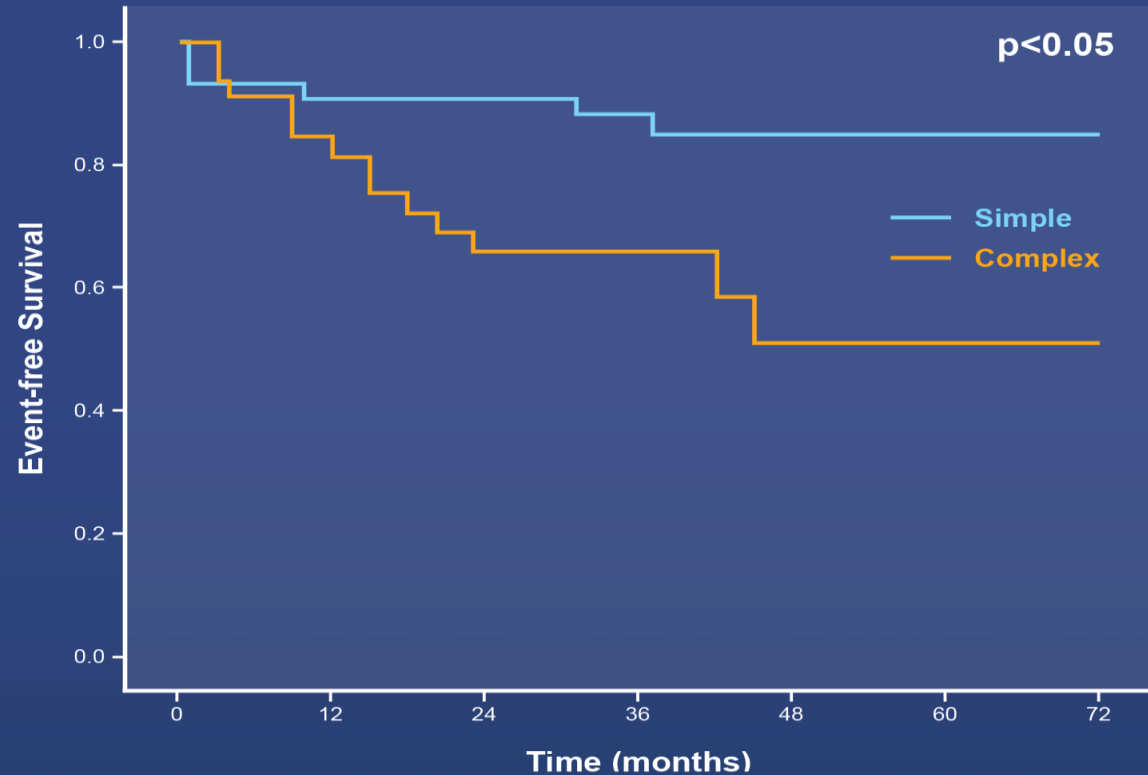

A simple strategy appeared to be a good treatment option, associated with a lower event rate at follow-up.

PCI vs. CABG for Distal Bifurcation LM stenosis

Post-hoc analysis of EXCEL Trial
(Distal bifurcation N=1559, Ostial/mid-shaft N=293)

Primary Endpoint: Death, MI or Stroke

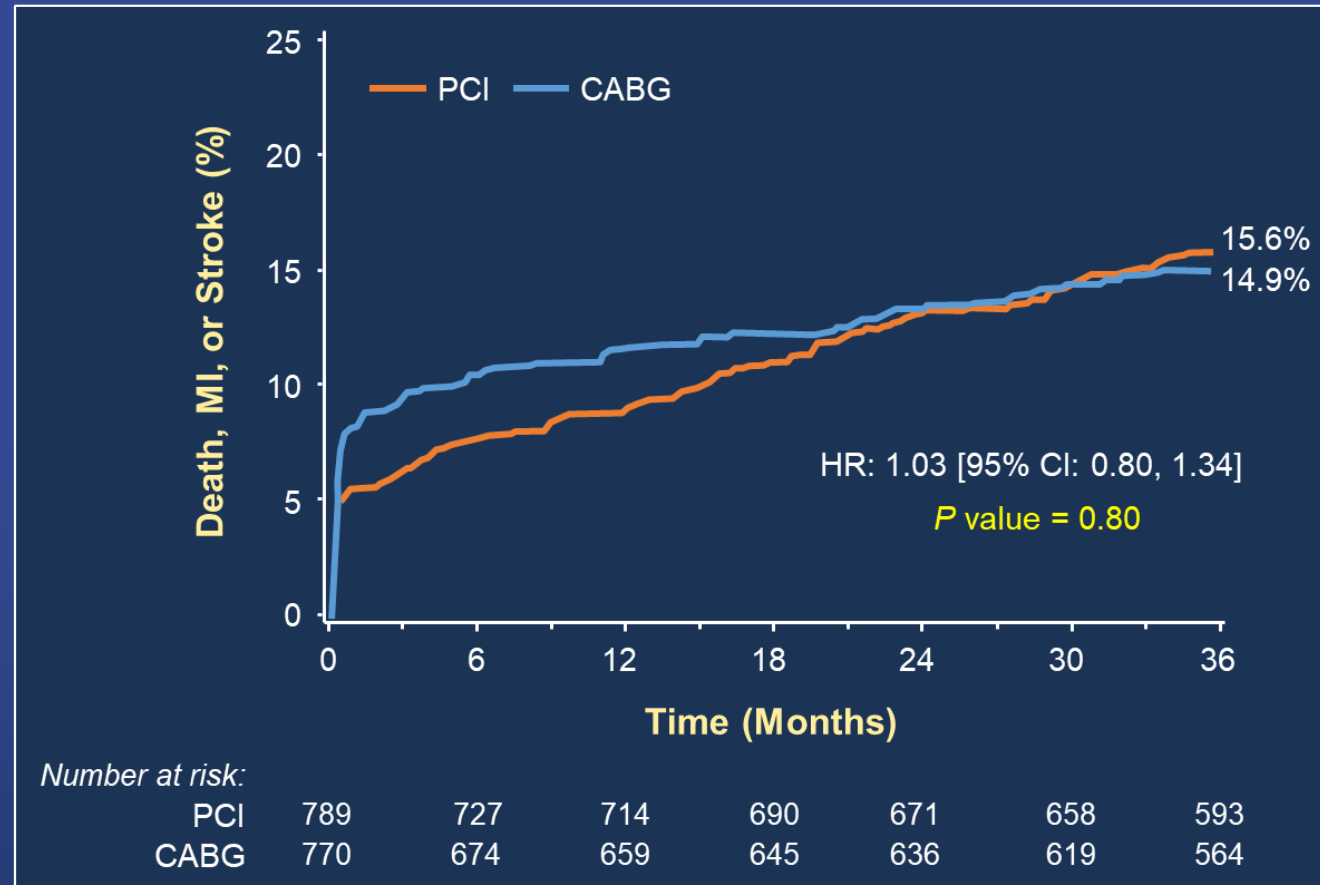

PCI vs. CABG for Ostial/Midshaft LM stenosis

Post-hoc analysis of EXCEL Trial
(Distal bifurcation N=1559, Ostial/mid-shaft N=293)

Primary Endpoint: Death, MI or Stroke

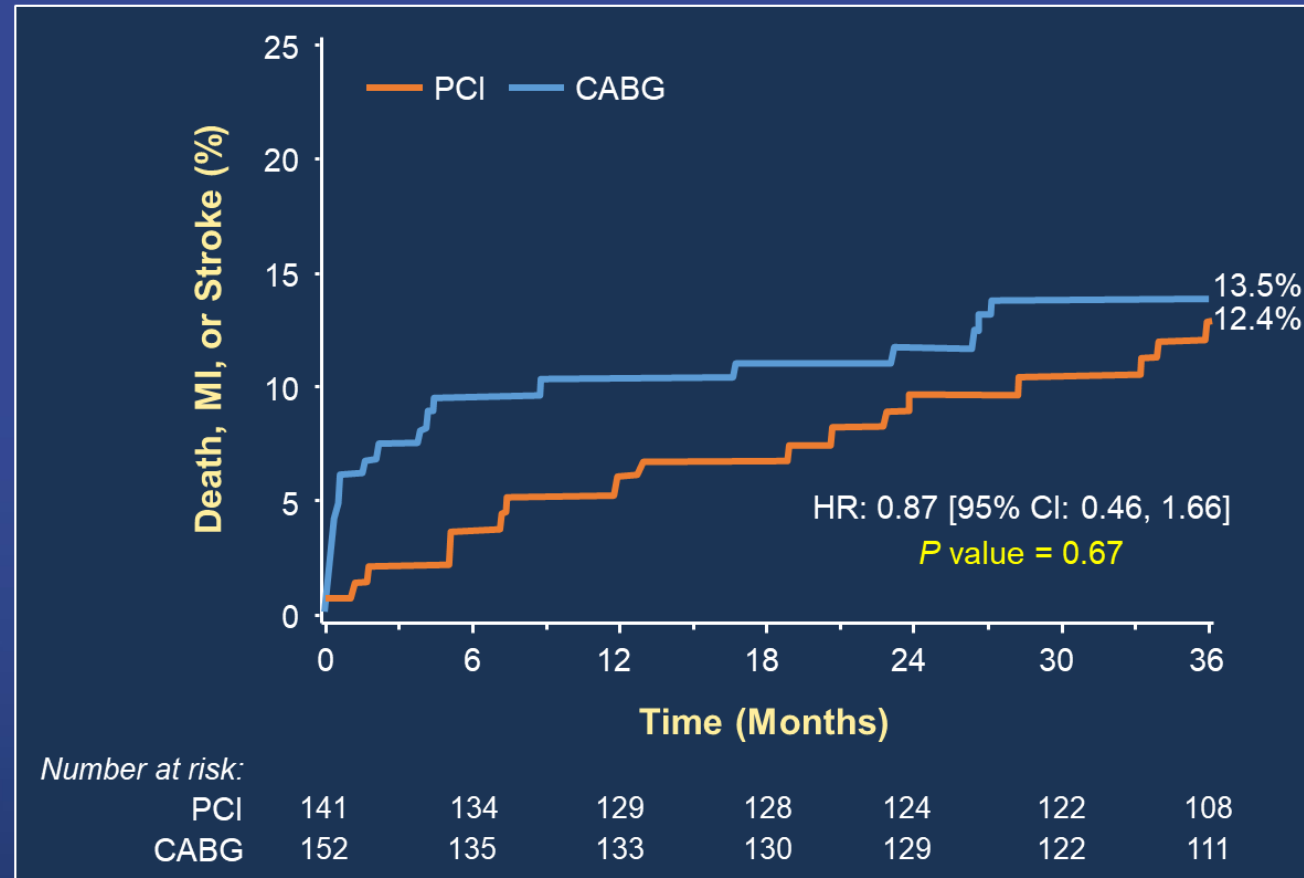

PCI vs. CABG for Distal Bifurcation LM stenosis

Post-hoc analysis of EXCEL Trial

(Distal bifurcation N=1559, Ostial/mid-shaft N=293)

Ischemia-driven Revascularization

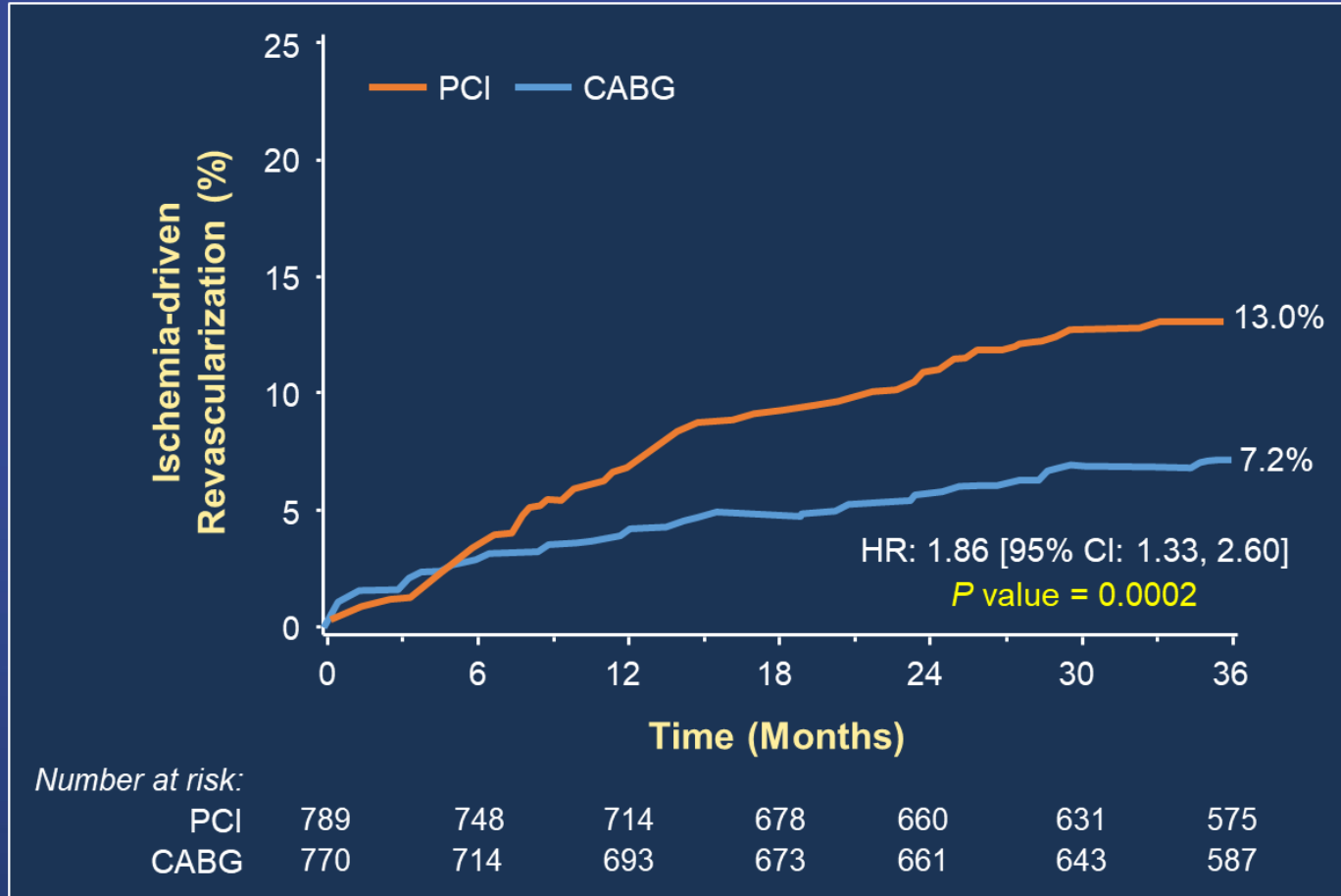

PCI vs. CABG for Ostial/Midshaft LM stenosis

Post-hoc analysis of EXCEL Trial
(Distal bifurcation N=1559, Ostial/mid-shaft N=293)

Ischemia-driven Revascularization

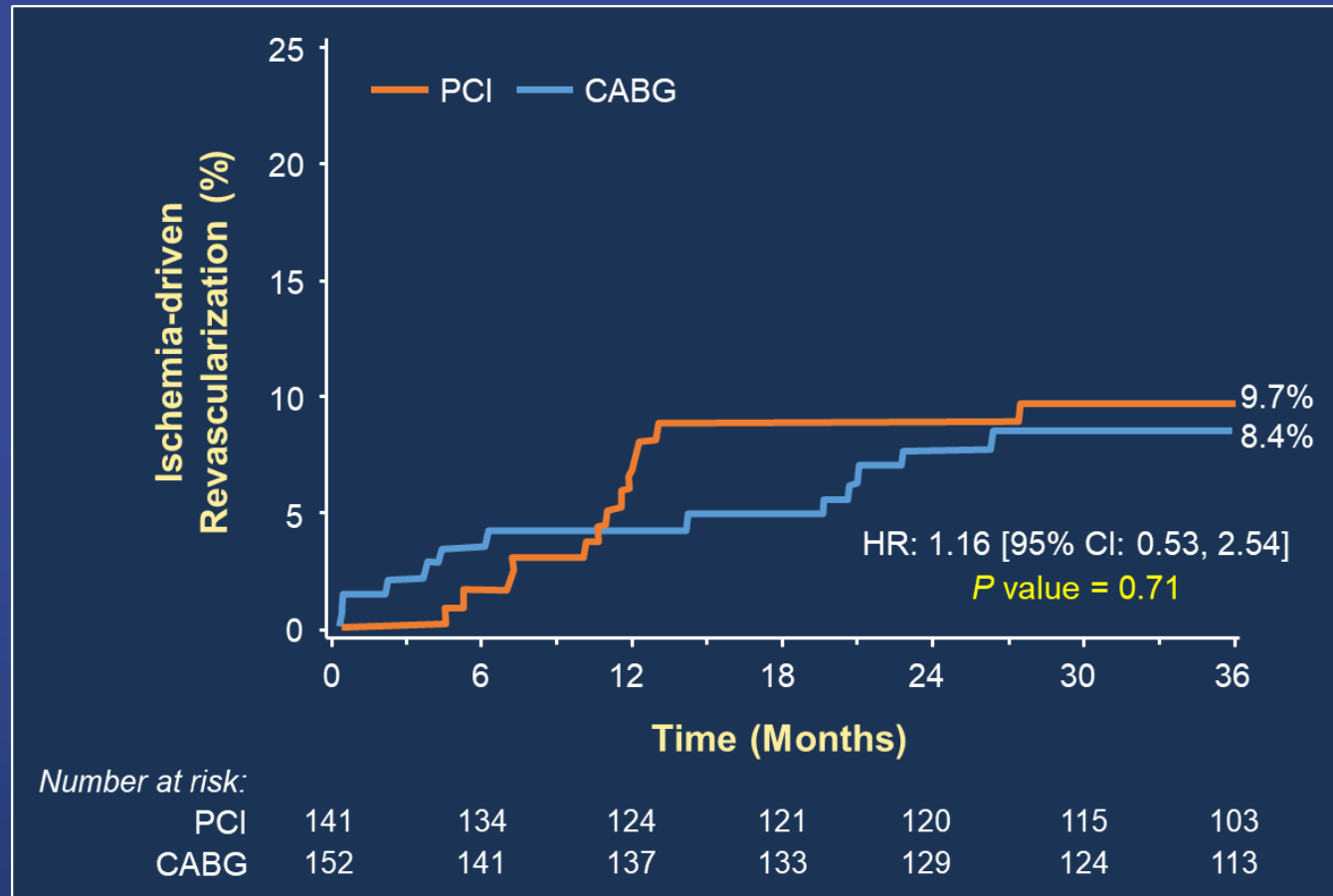

Mortality after LM reintervention

ISAR-LEFT-MAIN and ISAR-LEFT-MAIN2 registry

TABLE 2 Procedural Findings at the Index Procedure

	Alive (n = 119)	Dead (n = 47)	p Value
Location of left main lesion			0.88
Ostial	8.4 (10/119)	8.5 (4/47)	
Distal/bifurcation	81.5 (97/119)	78.7 (37/47)	
Body	10.1 (12/119)	12.8 (6/47)	
Occluded right coronary artery	9.2 (11/119)	14.9 (7/47)	0.29
Trifurcation morphology	14.3 (17/119)	10.6 (5/47)	0.53
Stenting technique			0.26
Single	45.4 (54/119)	57.4 (27/47)	
T-stenting	10.1 (12/119)	4.3 (2/47)	
Culotte stenting	44.5 (53/119)	38.3 (18/47)	
Kissing balloon technique	55.5 (66/119)	34.0 (16/47)	0.01
Coronary artery dominance			0.49
Left	8.4 (10/119)	10.6 (5/47)	
Right	82.4 (98/119)	74.5 (35/47)	
Balanced	9.2 (11/119)	14.9 (7/47)	
Stent type			0.02
Sirolimus-eluting stent	29.4 (35/119)	8.5 (4/47)	
Zotarolimus-eluting stent	27.7 (33/119)	44.7 (21/47)	
Paclitaxel-eluting stent	17.6 (21/119)	23.4 (11/47)	
Everolimus-eluting stent	25.2 (30/119)	23.4 (11/47)	

Values are % (n/N).

TABLE 3 Mortality After Target Lesion Revascularization According to Lesion Location and Revascularization Strategy

	Mortality at 3 Years	Mortality at 5 Years	p Value
Lesion location			0.90
Ostial	14.3 (2)	31.8 (4)	
Distal/bifurcation	20.6 (27)	29.3 (37)	
Body	23.7 (4)	36.4 (6)	
Underlying stenting technique			0.30
Single	20.3 (16)	35.5 (27)	
T-stenting	14.9 (2)	14.9 (2)	
Culotte	21.5 (15)	26.9 (18)	
Revascularization type			0.90
CABG	18.1 (3)	24.4 (4)	
PTCA	24.1 (19)	31.5 (24)	
Stenting	16.5 (11)	29.9 (19)	

Values are % by Kaplan-Meier estimate (n).

Simple cross
vs.
Two-stent technique

EBC MAIN trial

LM bifurcation: 1 vs. 2 stent tech.

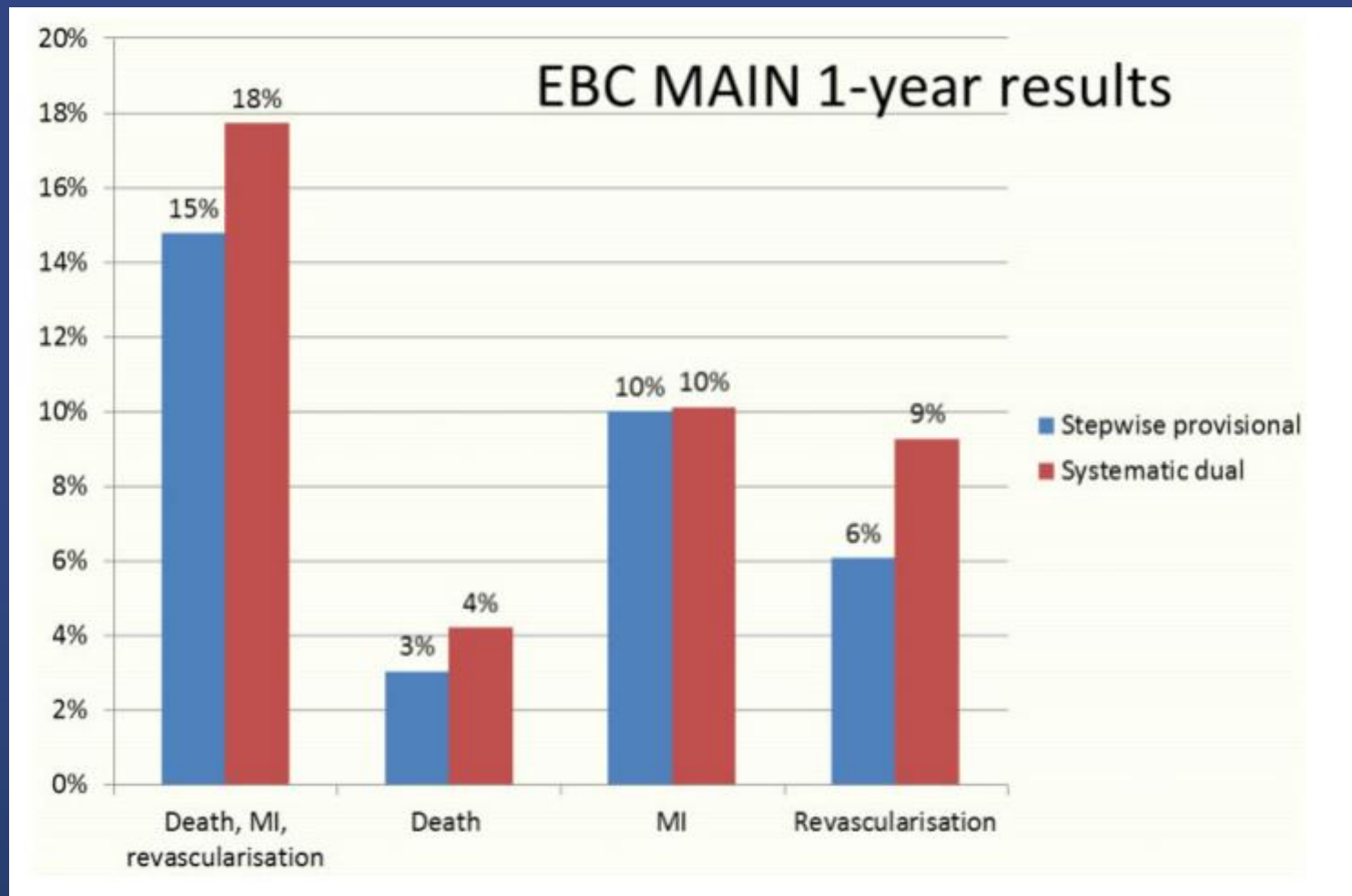

EBC MAIN trial

LM bifurcation: 1 vs. 2 stent tech.

Primary Endpoint : a composite of death, myocardial infarction, and target lesion revascularization at 12month

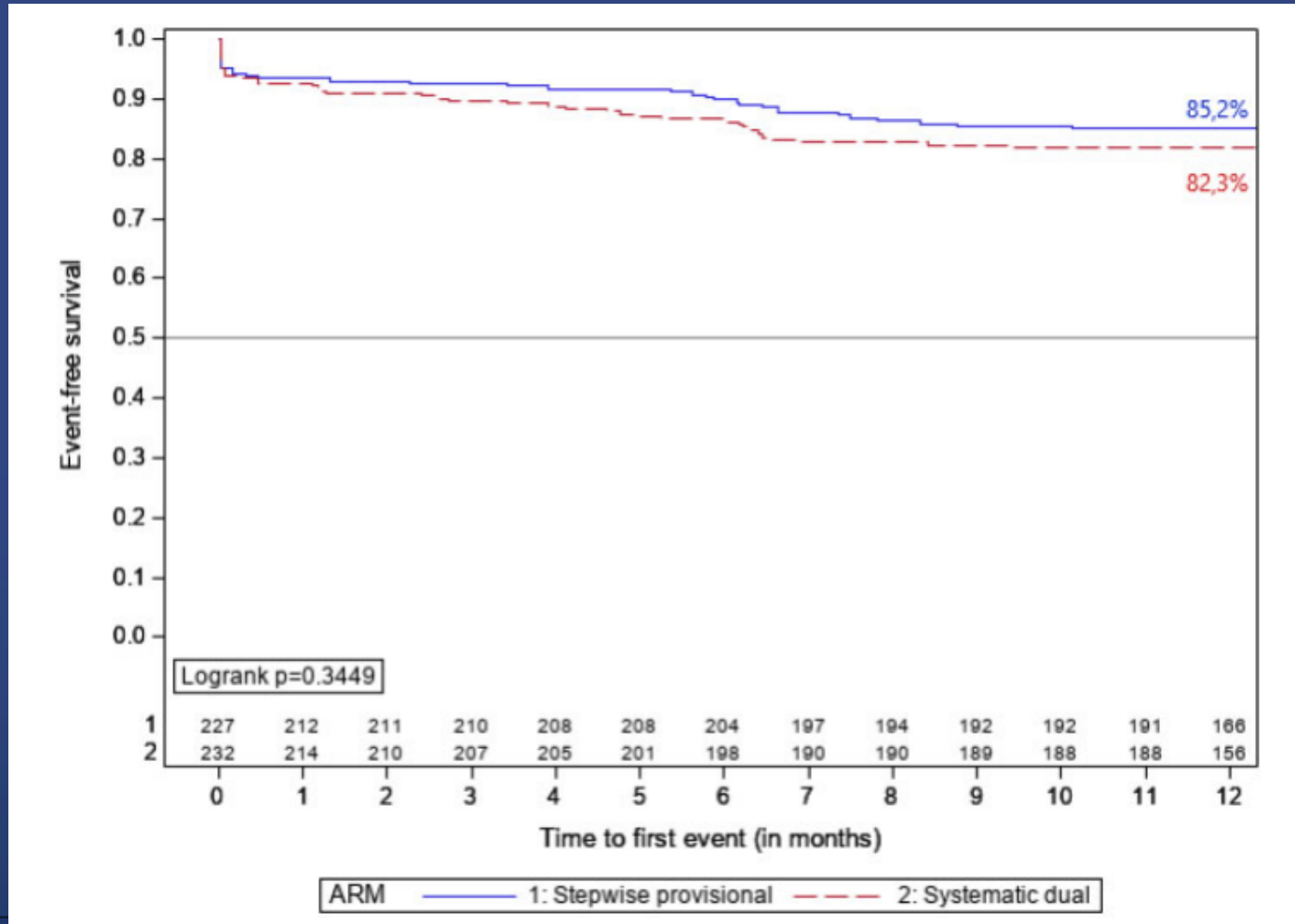

DEFINITION II trial

LM bifurcation: Two stent vs. provisional stenting

Primary Endpoint : target lesion failure, target lesion revascularization, target vessel myocardial infarction

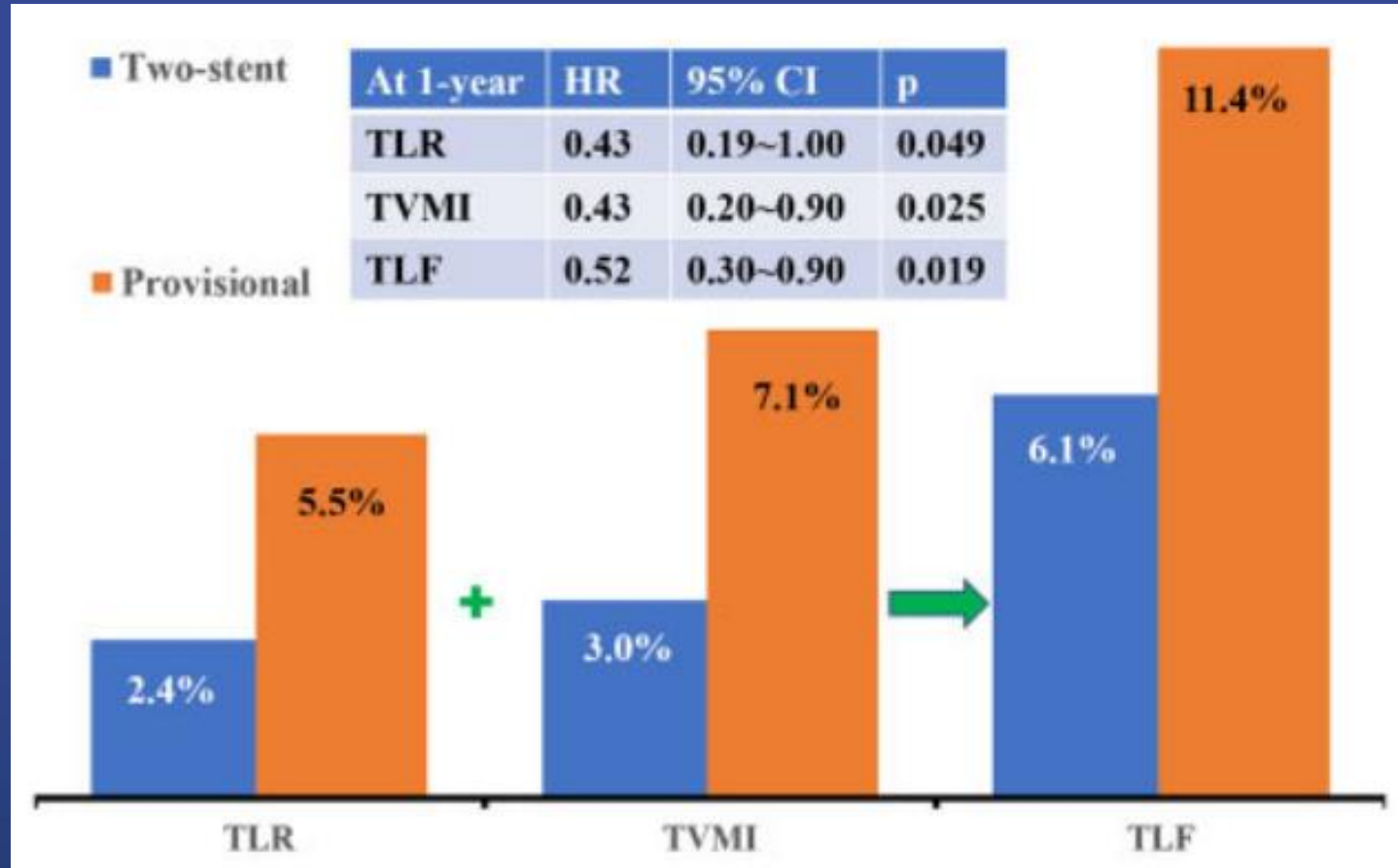

Ostial vs. 1 stent vs. 2 stent

TLR :Treated with DES

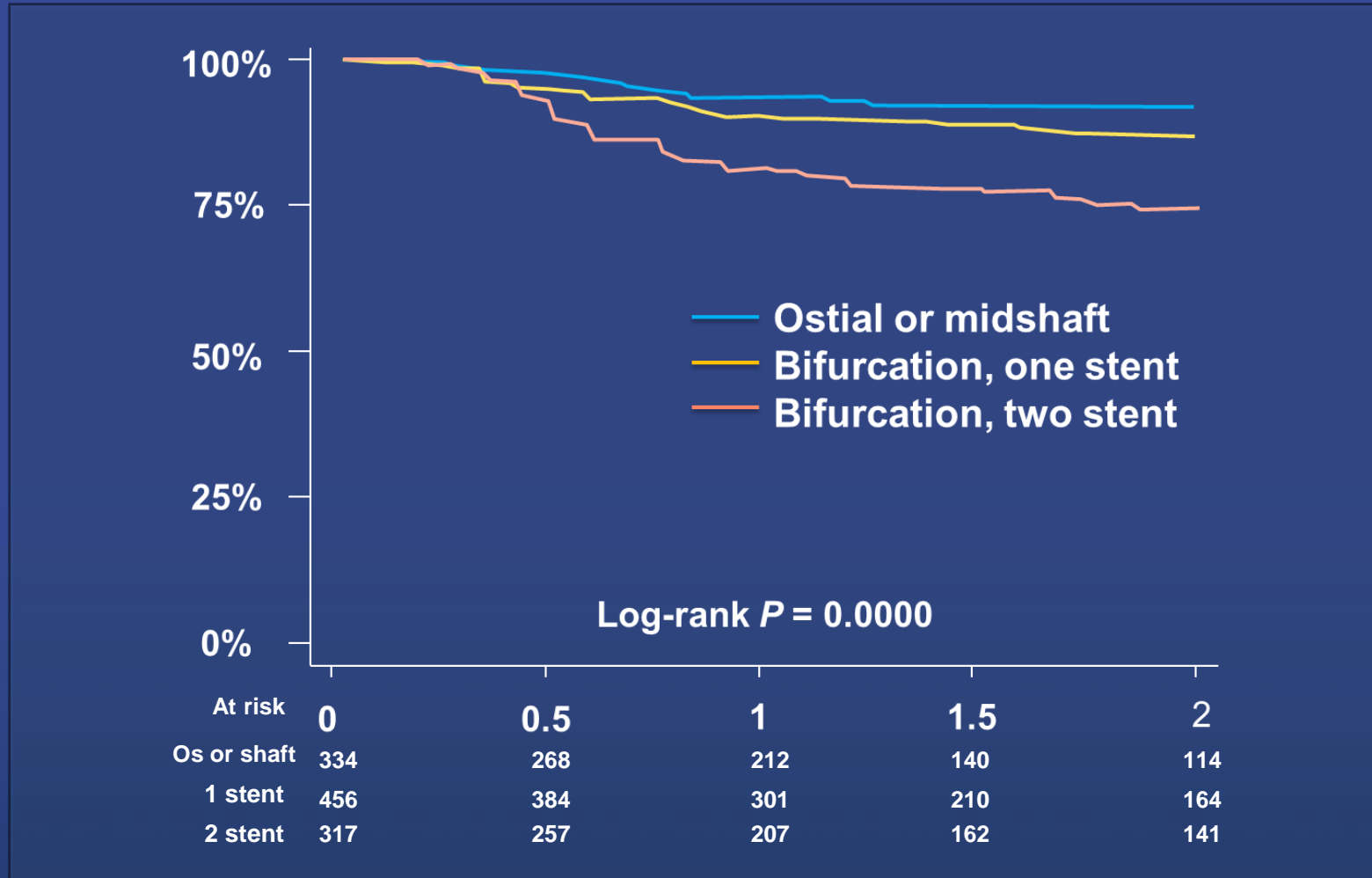

Single- vs. Two-Stent Strategy from MAINCOMPARE

Death

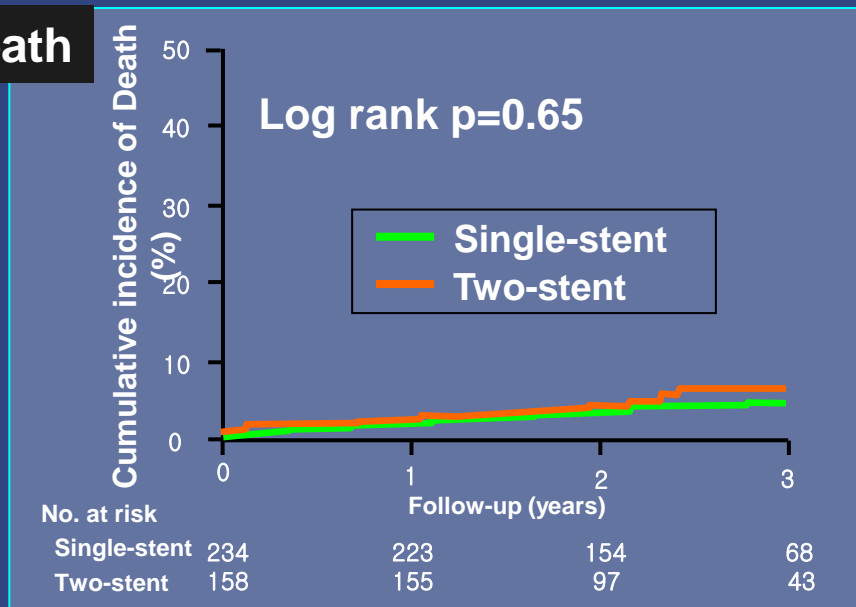

MI

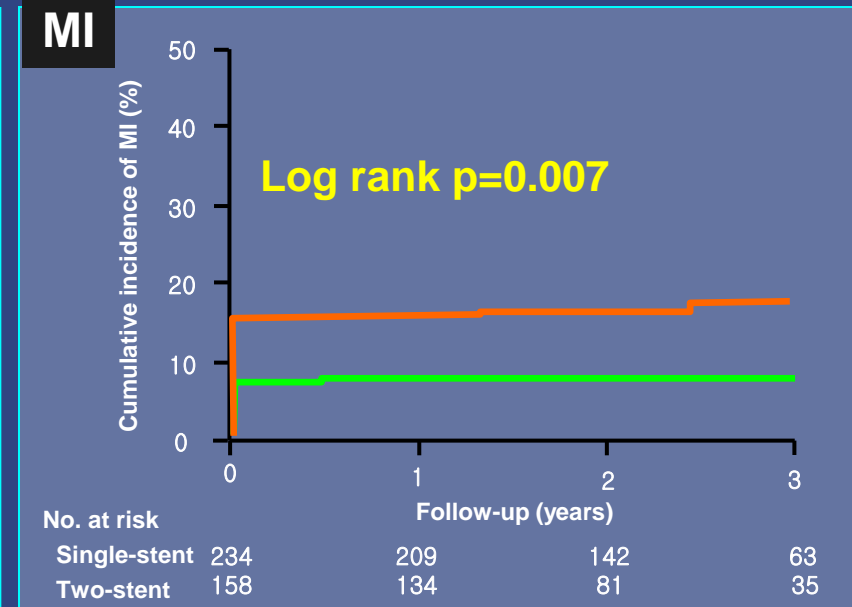

TLR

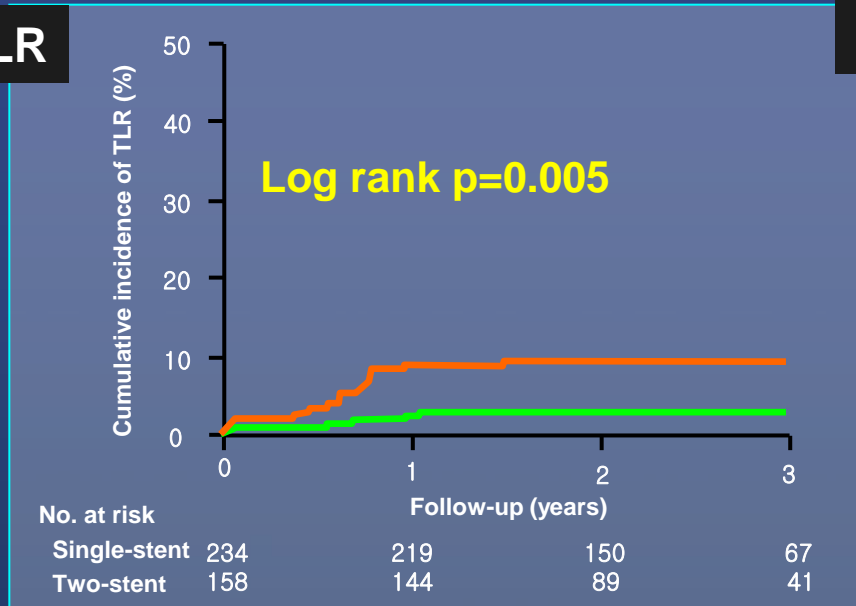

MACE

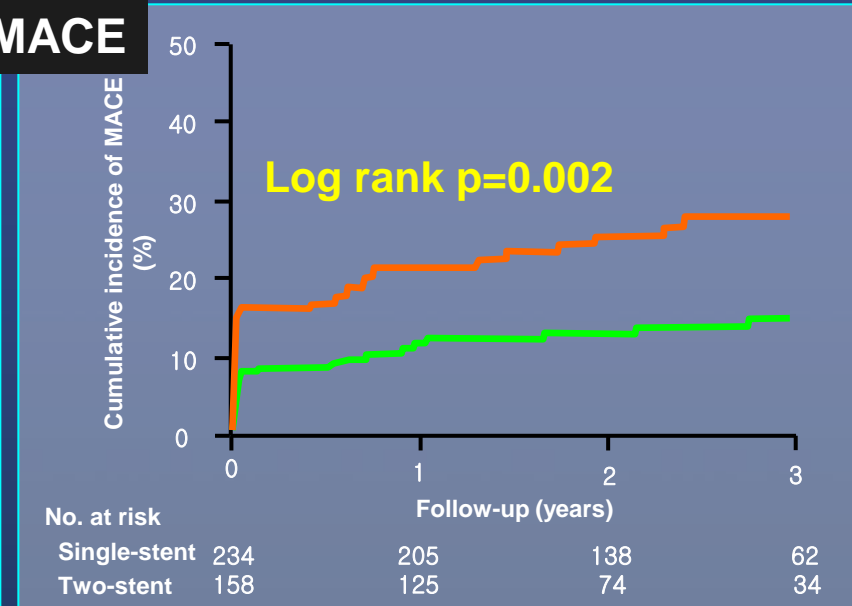

COBIS Registry II

LM bifurcation: 1 vs. 2 stent tech.

Target lesion failure : cardiac death, MI, and TLR

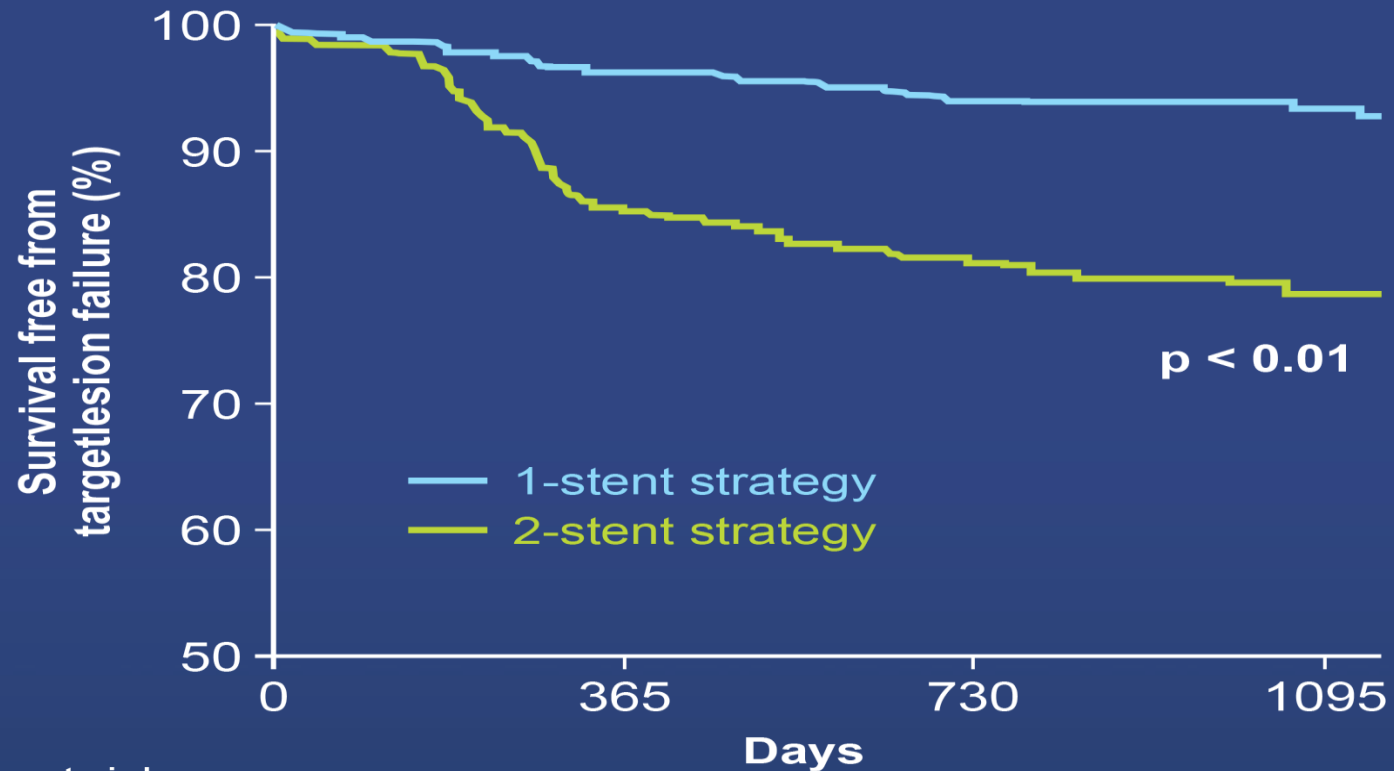

Numbers at risk

1-stent strategy	509	455	374	219
2-stent strategy	344	271	216	129

Song YB et al. JACC: Cardiovasc interv, 2014

IVUS-guided, Lesion-specific

Single stent

- Normal ostial LCX with MEDINA 1.1.0. or 1.0.0.
- Small LCX with < 2.5 mm in diameter
- Diminutive LCX
- Normal or focal disease in distal LCX

Two stent

- Diseased LCX with MEDINA 1.1.1., 1.0.1., or 0.1.1
- Large LCX with ≥ 2.5 mm in diameter
- Diseased left dominant coronary system
- Concomitant diffuse disease in distal LCX

Park SJ, Kim YH. Colombo A, Issam D. Moussa et al. Textbook of Bifurcation Stenting

Provisional vs. 2-stent technique for Simple and Complex Bifurcation Lesions - The DEFINITION Study

Adjusted HR with 2-stent technique

	Simple	Complex
In-hospital		
MI	0.76 (0.45–1.28)	0.58 (0.35–0.94)
Cardiac death	—	0.53 (0.13–2.12)
TLR	1.66 (0.41–1.66)	—
MACE	0.68 (0.40–1.13)	0.58 (0.35–0.94)
Stent thrombosis	6.68 (1.67–26.80)	—
At 1 year		
MI	0.68 (0.40–1.13)	0.64 (0.40–1.03)
Cardiac death	0.95 (0.38–2.34)	0.52 (0.28–0.97)
TLR	1.78 (1.16–2.74)	1.07 (0.65–1.75)
MACE	1.03 (0.75–1.42)	0.79 (0.57–1.08)
Stent thrombosis	1.66 (0.62–4.45)	1.06 (0.42–1.69)

2-stent technique is still needed for complex bifurcation lesions

FFR- vs. Angio-guided Provisional Stenting

The Randomized DKCRUSH-VI Trial

(160 patients with true bifurcation lesion in each group)

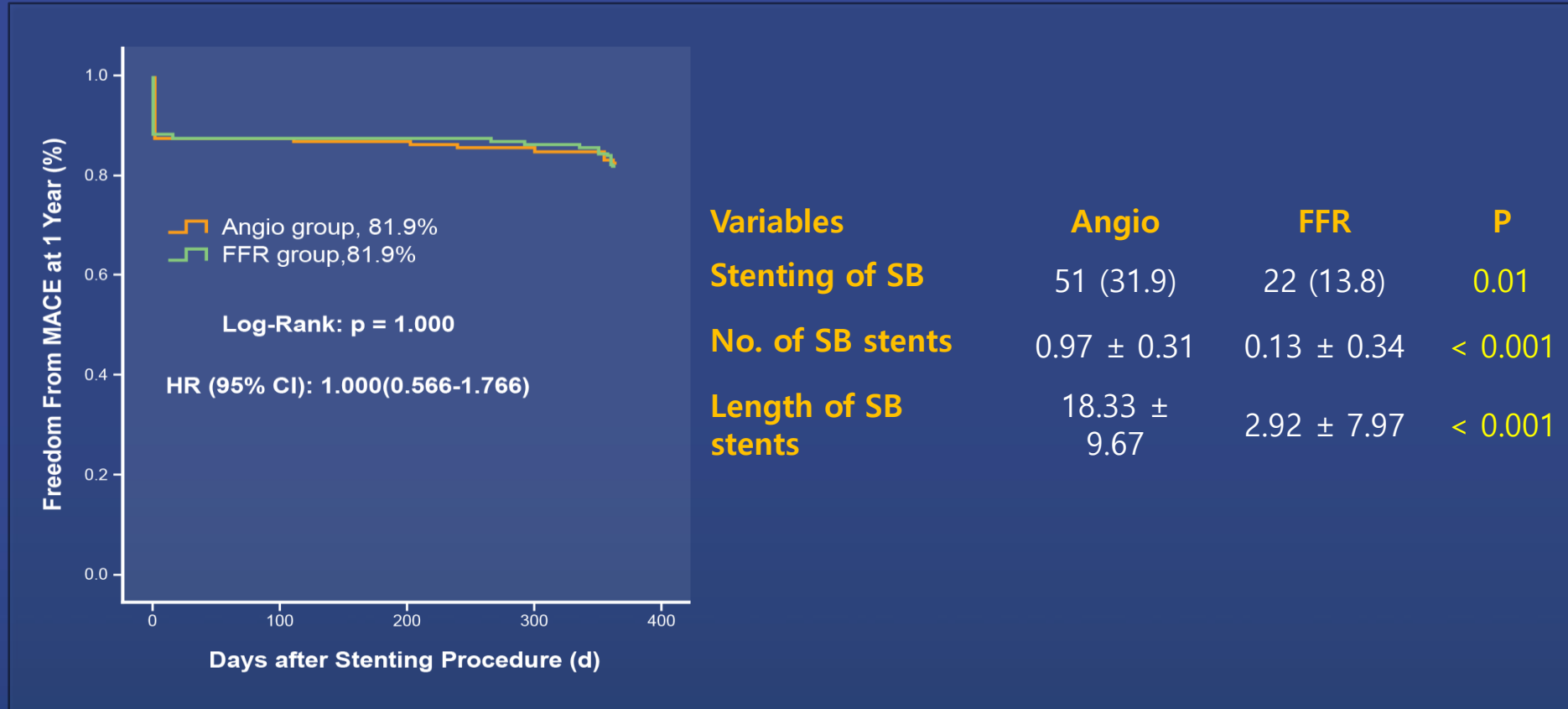

FFR-guided provisional stenting showed the similar outcomes with fewer stents

DKCRUSH III

DKCRUSH vs. Culotte for LM-bifurcation

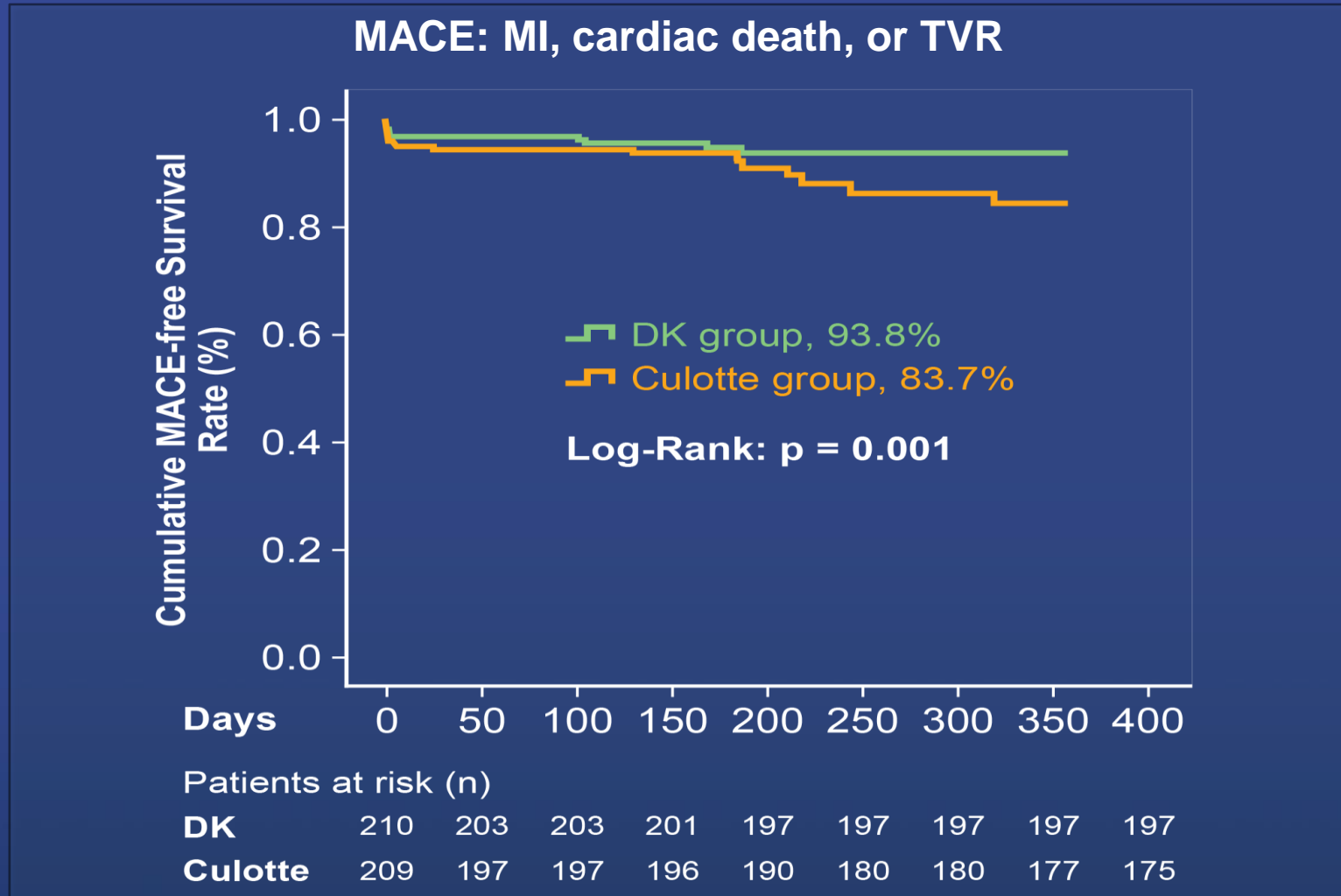

Risk Prediction of SB Occlusion

The RESOLVE Score System

: a model built from 1545 Chinese patients with bifurcation

Scores Attributed to Each Variable

Risk Factor	Level	Point
Plaque distribution	At the opposite side of SB	0
	At the same side of SB	1
MV TIMI flow grade before stenting	TIMI 3	0
	TIMI 2	6
	TIMI 1	11
	TIMI 0	17
Pre-procedural diameter stenosis of bifurcation core (%)	<50	0
	50–<70	2
	≥70	3
Bifurcation angle (°)	<70	0
	70–<90	4
	≥90	6
Diameter ratio between MV/SB	<1.0	0
	1.0–<1.5	2
	1.5–<2.0	6
	≥2.0	9
Diameter stenosis of SB before MV stenting (%)	<50	0
	50–<70	4
	70–<90	6
	≥90	7

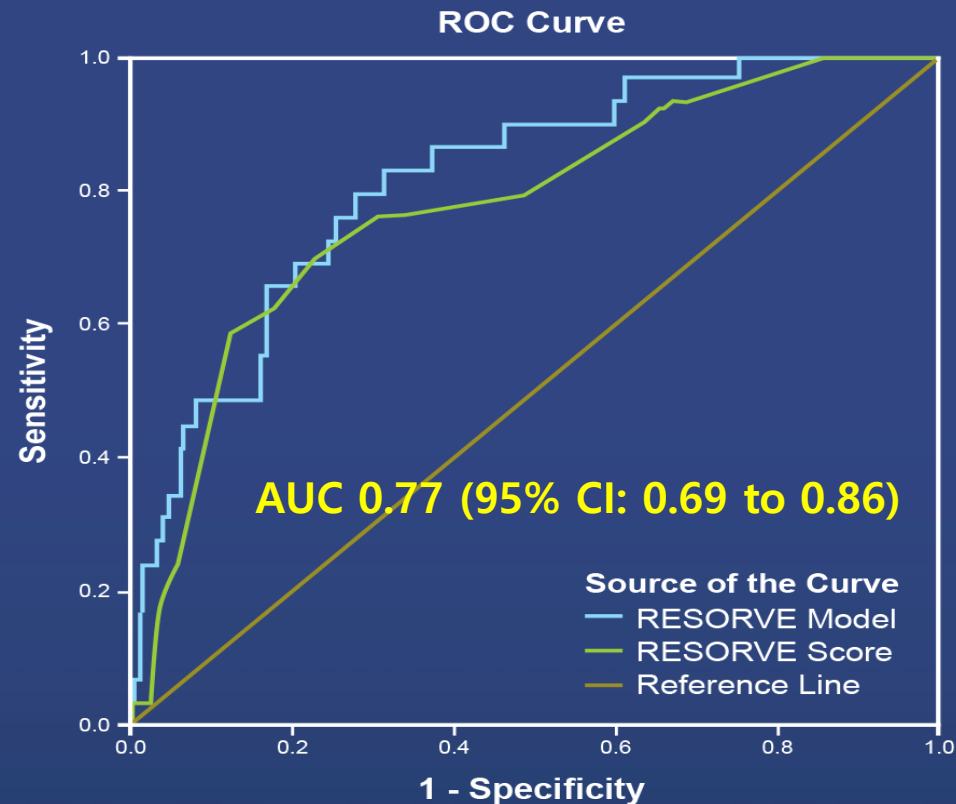

The RESOLVE score system can help identify patients at risk for SB occlusion during bifurcation stenting.

Effect of SB Predilation Before Provisional Stenting

A randomized study enrolling 372 patients with true bifurcation
(SB predilation + vs. SB predilation -)

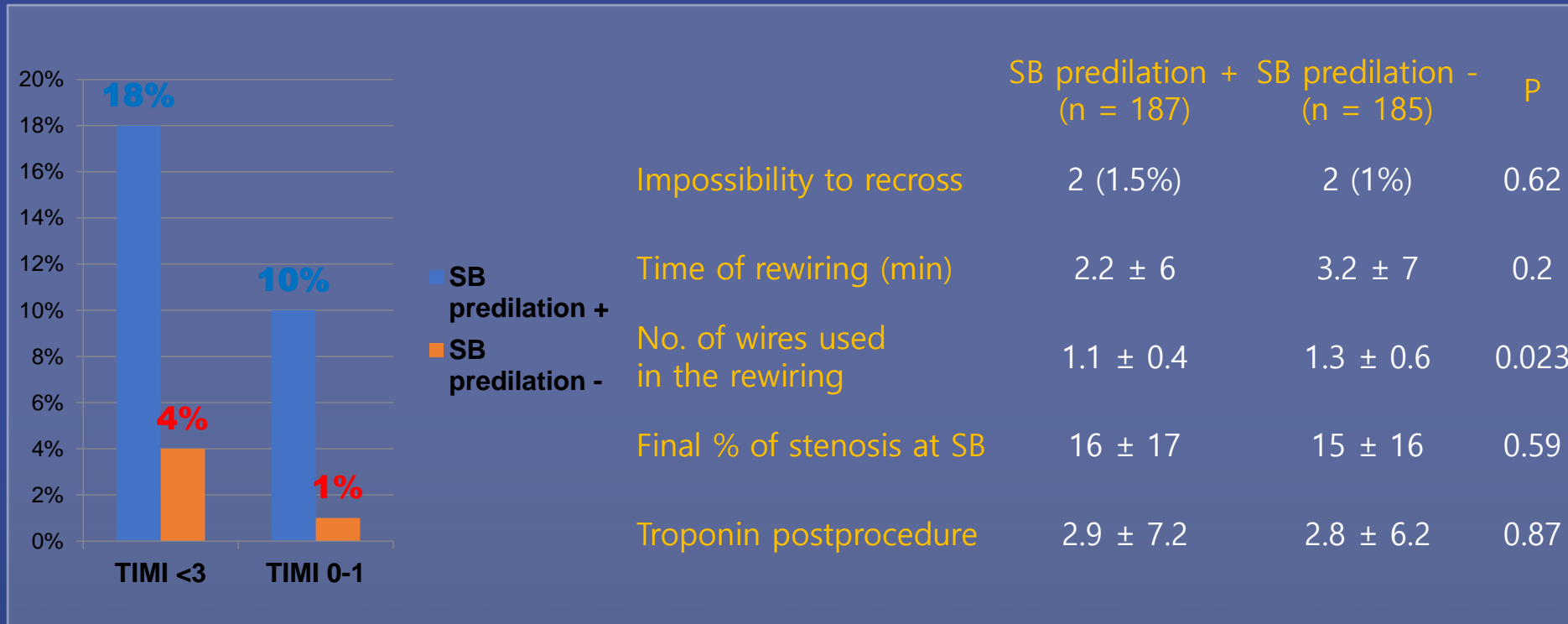

Predilation of the SB resulted in improved TIMI flow after MB stenting,
not hindering SB rewiring.

With vs. Without Routine Kissing Balloon Inflation (FKB)

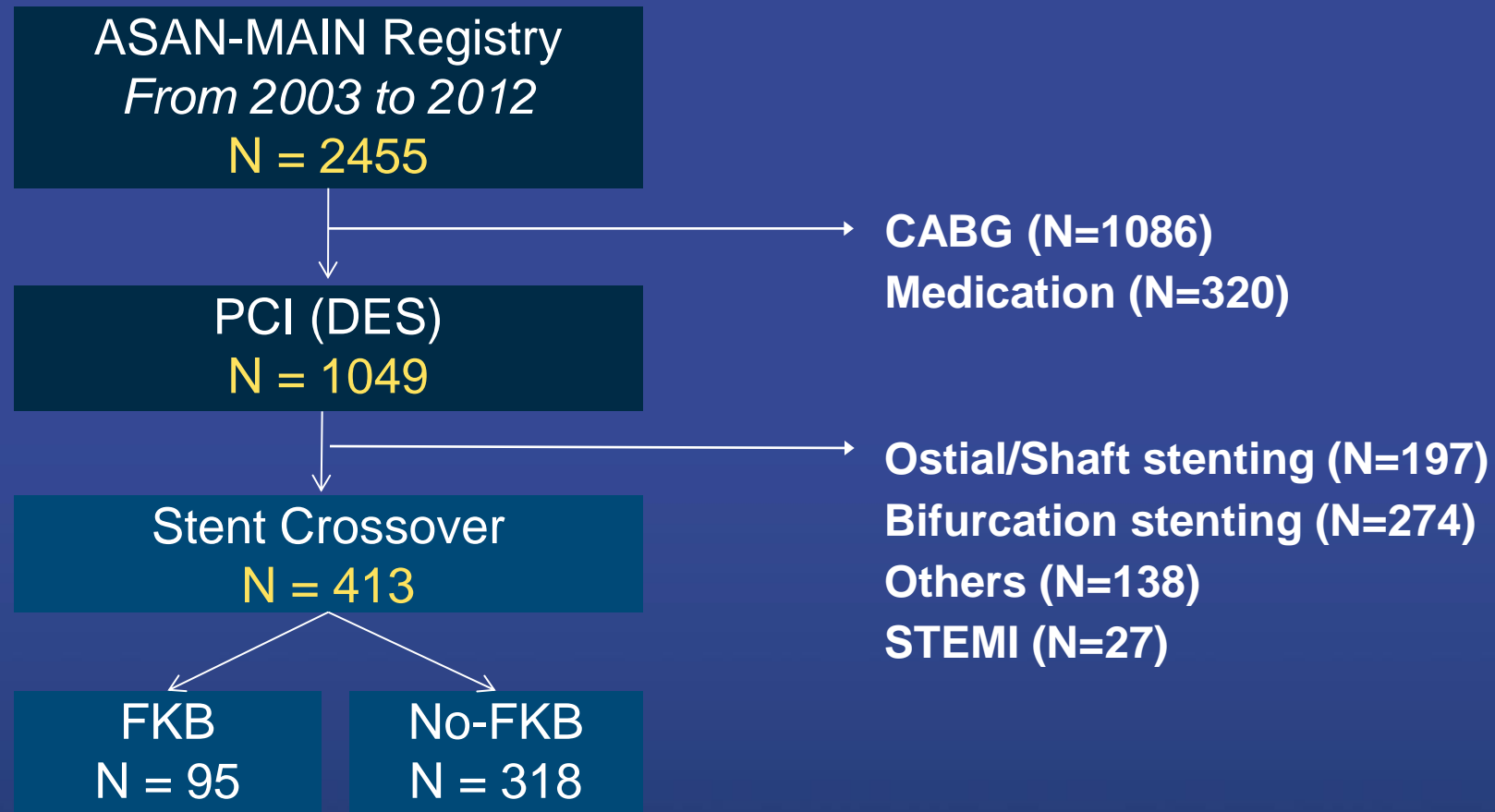

With vs. Without Routine Kissing Balloon Inflation (FKB) 2- year Clinical Outcomes

	FKB (N=95)	Non-FKB (N=318)	Adjusted HR (95% CI)	P value
Death	4 (4.6%)*	12 (3.9%)	1.03 (0.28-3.82)	0.97
Death or MI	4 (4.6%)	13 (4.2%)	0.95 (0.26-3.51)	0.96
TVR	7 (8.1%)	14 (4.8%)	1.12 (0.40-3.11)	0.83
LM-TLR	7 (8.1%)	13 (4.4%)	1.32 (0.46-3.75)	0.60
Definite ST	0	0	NA	NA
MACE#	11 (12.5%)	26 (8.5%)	1.10 (0.49-2.49)	0.82

adjusted for age, DM, clinical presentation, stent No., pre- and post-stenting LCX DS

** derived from Kaplan-Meier estimate*

composite of death, MI, or LM TLR

DKCRUSH-V Randomized Trial

DKCRUSH vs. Provisional stenting for LM distal bifurcation

Primary Endpoint: TLF (Cardiac death, TVMI, or TLR)

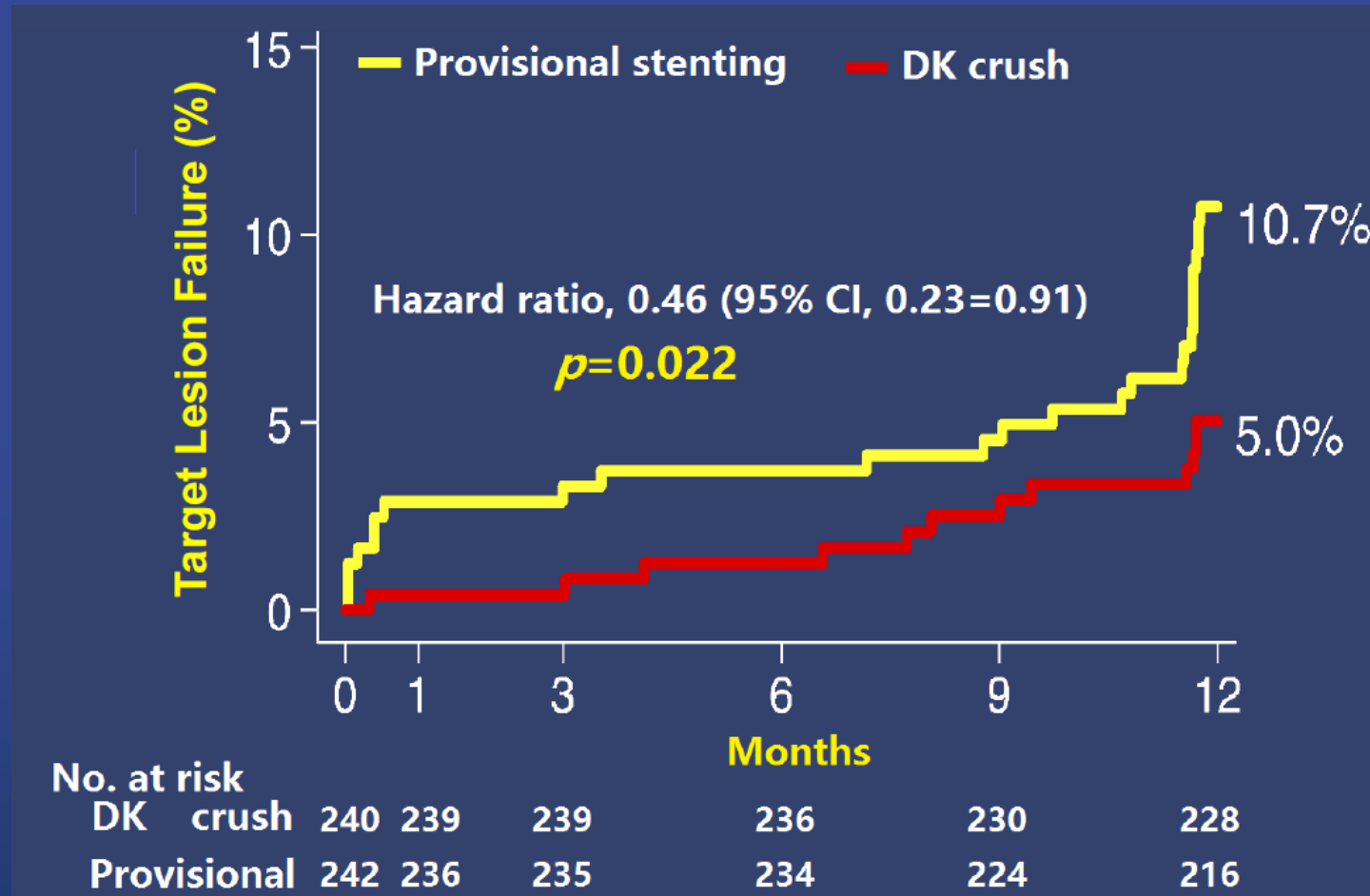

DKCRUSH-V Randomized Trial

DKCRUSH vs. Provisional stenting for LM distal bifurcation

Target Lesion Failure at 1-Year Subgroup analysis

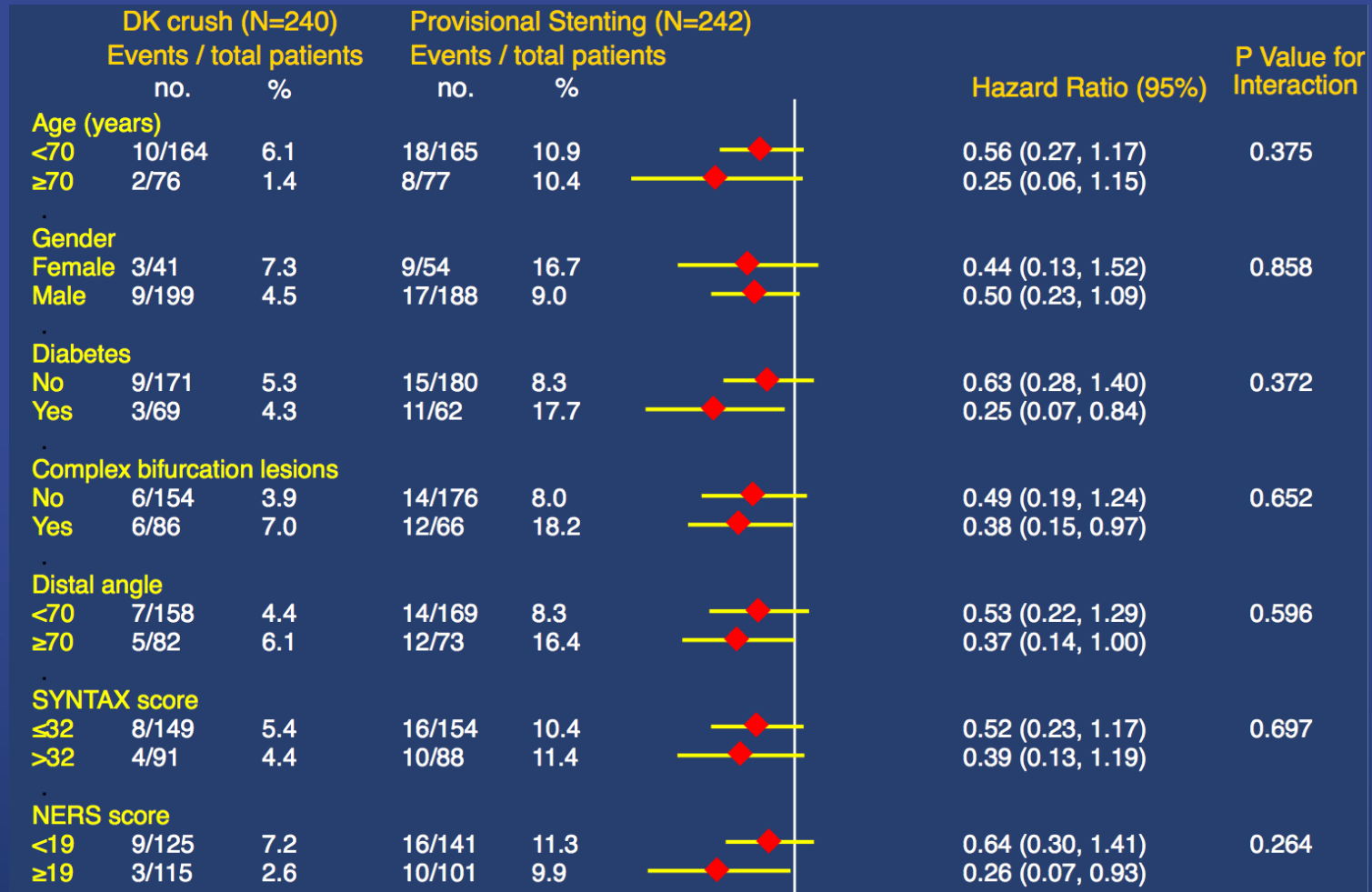

Favors DK crush Favors Provisional stenting

Bifurcation technique

Bifurcation Coronary Disease

- **15~20% of PCI patients**
- **DES enhanced success rate, but have not resolved completely**
- **Dependable strategy – not established**
 - Rare studies evaluating anatomical intricacies
 - Lack of large randomized trials
 - Many anatomical variants

→ Single technique can't fit all

Difficulties of Bifurcation PCI

- | **Risk of periprocedural complication**
- | **Relatively high restenosis**
- | **Not all lesions are the same**
 - Size of vessels (Meaningful SB size $\geq 2.25\text{mm}$)
 - Variable plaque distribution
 - Extent of SB disease
 - Variable angulation
- | **Higher risk of stent thrombosis**

PCI techniques are mainly based on personal experiences from skilled operators

Factors to be considered for PCI strategy

| Anatomical factors

- LMCA bifurcation
- Location of plaque (Anatomical classification)
- Plaque or carina shift
- Angle btw SB and MB
- Dynamic change in bifurcation anatomy

| Modalities for objective anatomical evaluation

- QCA, IVUS, FFR

| Selection of devices and strategies

- DES vs. BMS
- Single vs. Double stent techniques
- Kissing balloon or not
- Dedicated bifurcation stents

Medina Classification

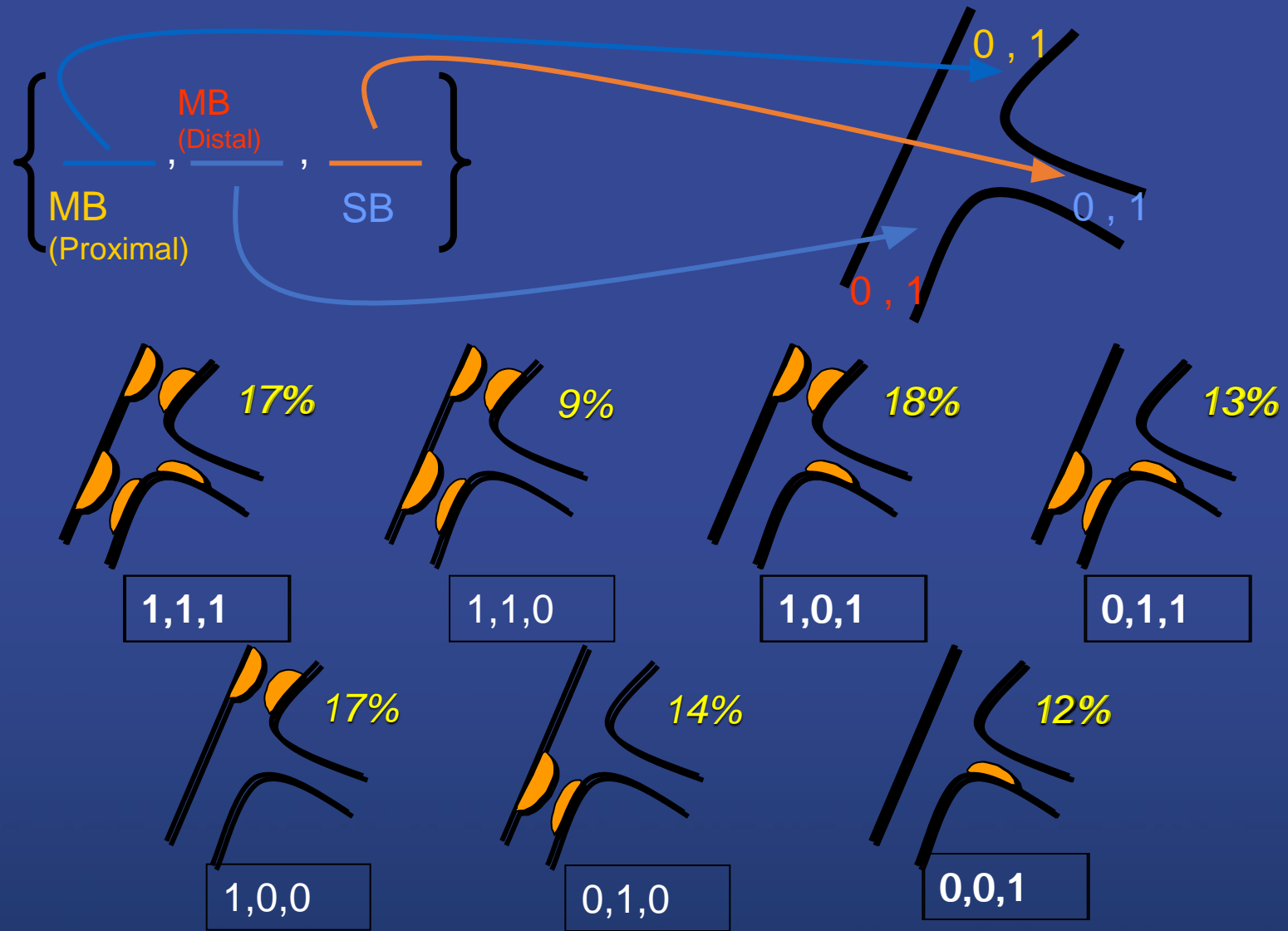

Trifurcation

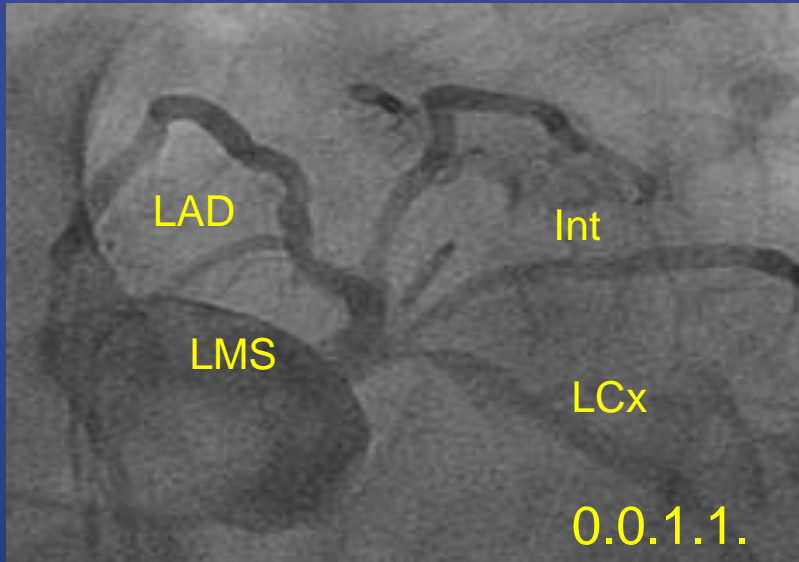
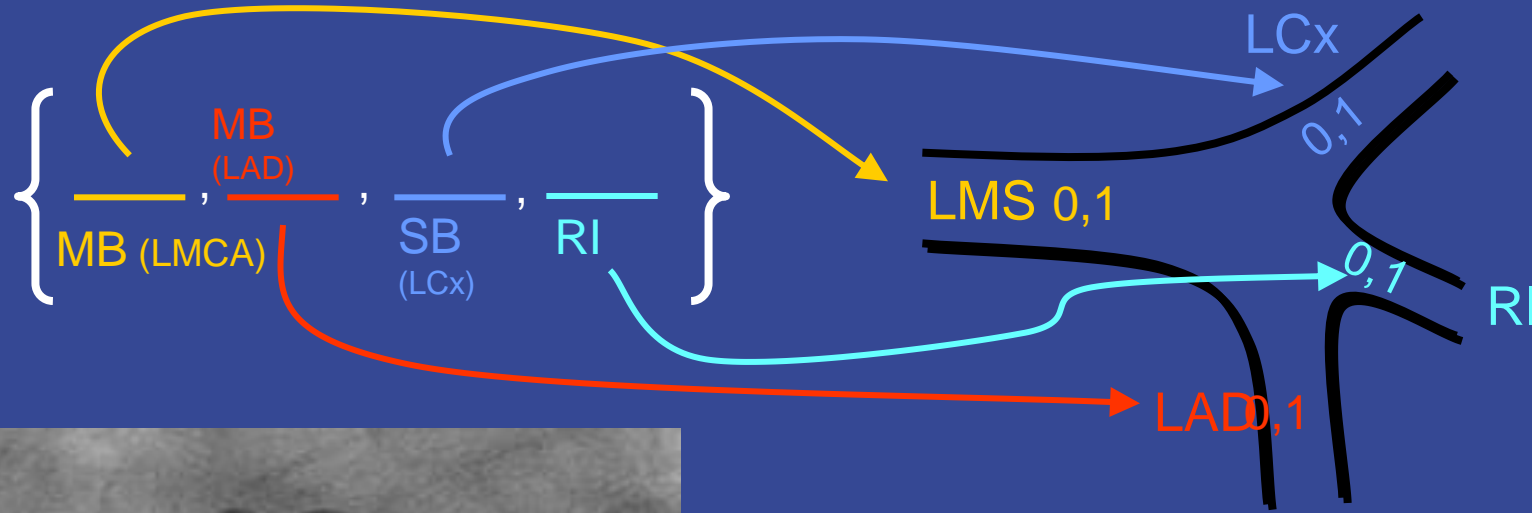

- If, RI size > LCx
→ LM, LAD, RI, LCx

Angulation

T-shape

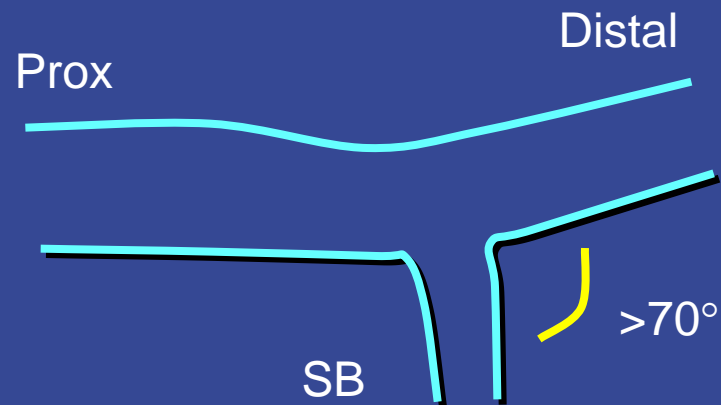

- **Difficult SB access**
- **Less plaque shifting**
- **T-stenting better**

Y-shape

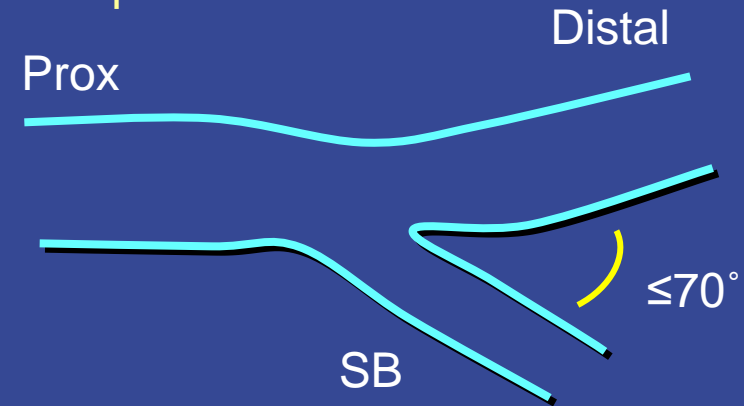

- **Easier SB access**
- **More plaque shifting**
- **Culotte or Crush better**

Stenting Crossing Side Branch With Optional Kissing Balloon Inflation

Normal or diminutive side branch ostium

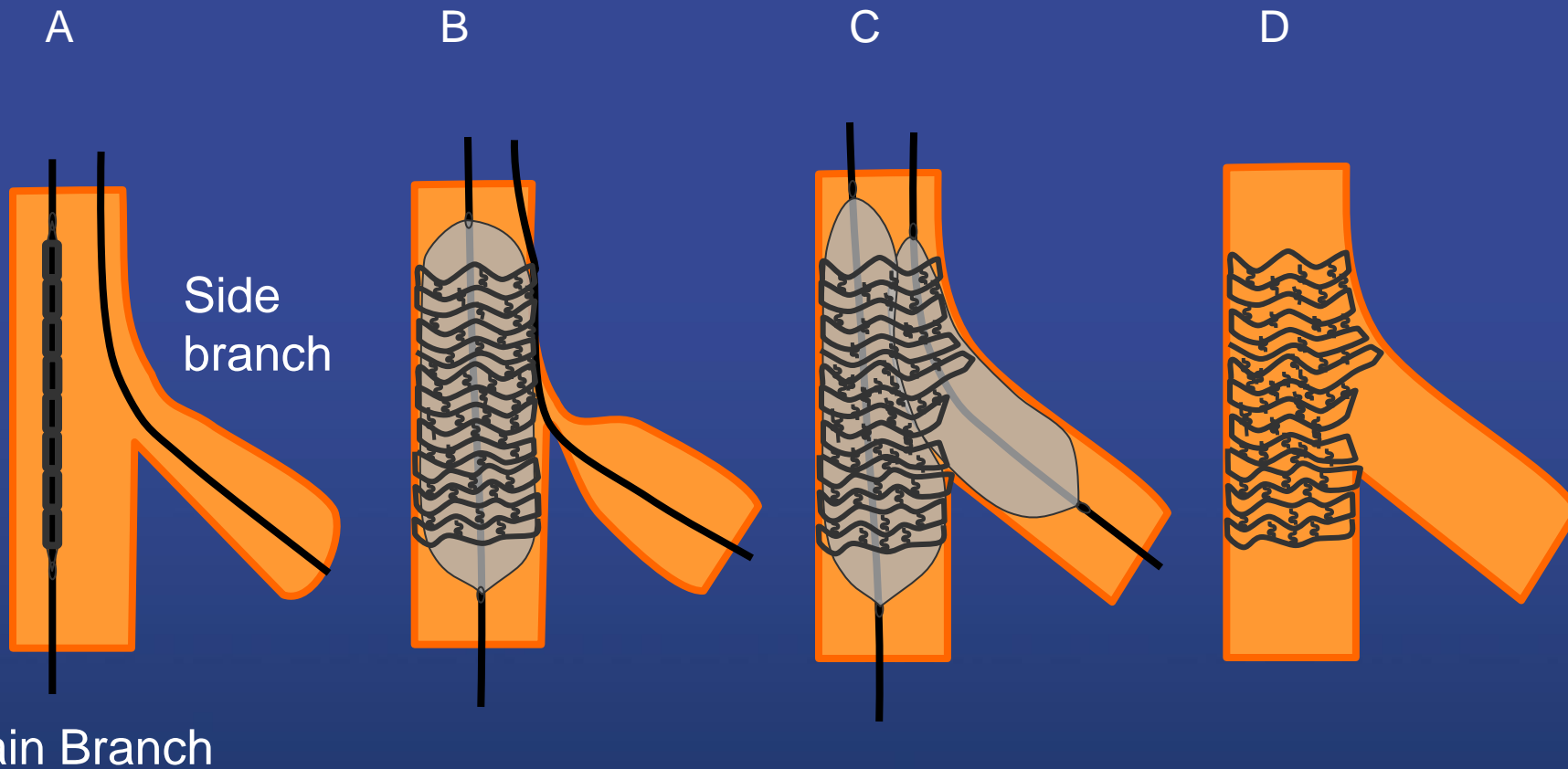

Stenting Crossing Side Branch With Optional Kissing Balloon Inflation

A. Wire both branches and predilate if needed

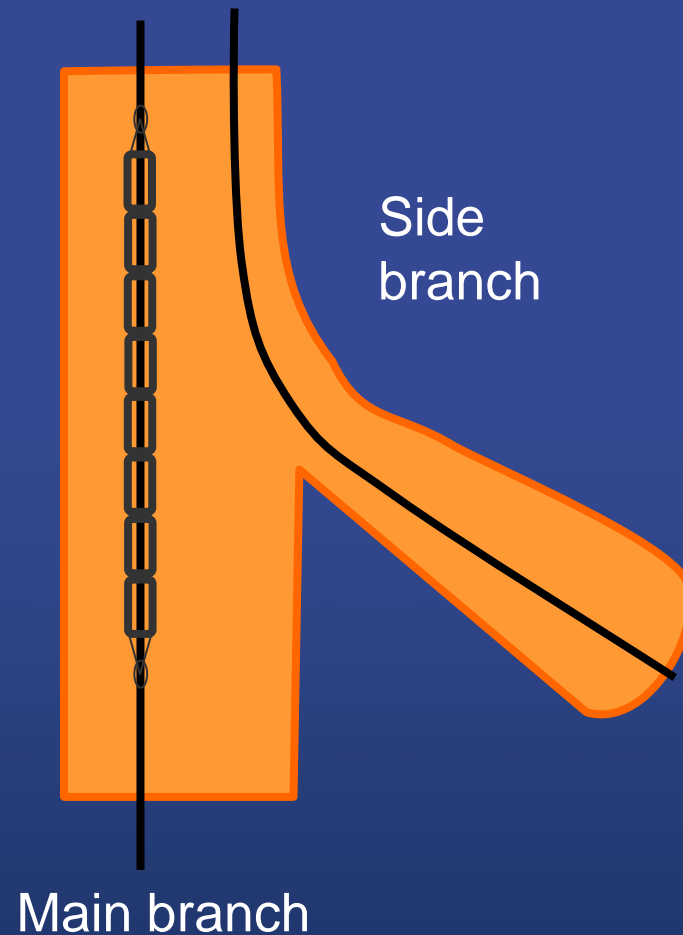

Stenting Crossing Side Branch With Optional Kissing Balloon Inflation

B. Stent the MB leaving a wire in the SB

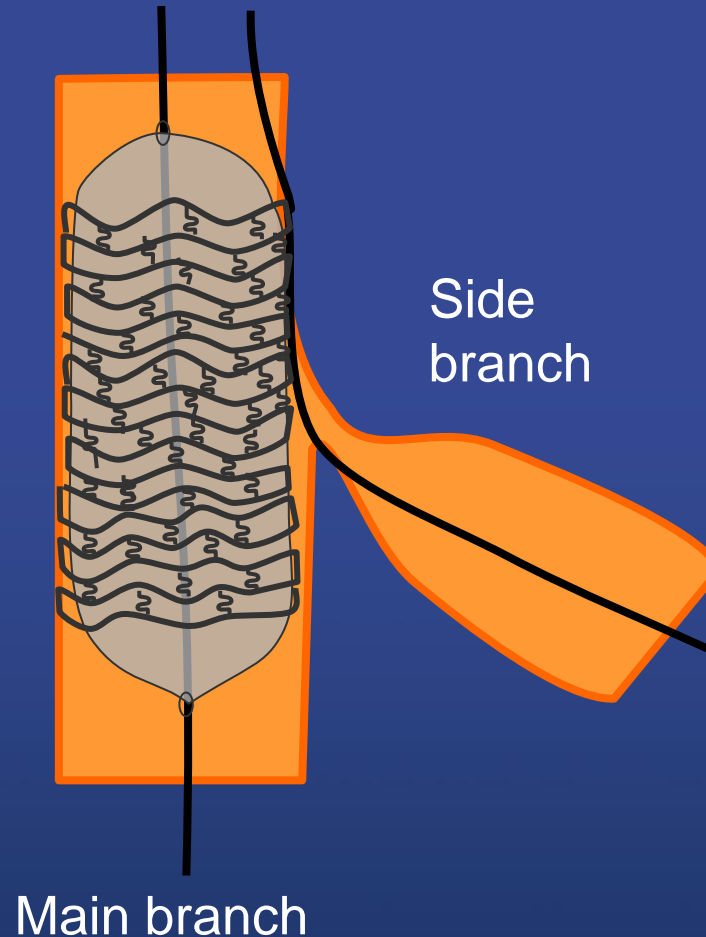

Stenting Crossing Side Branch With Optional Kissing Balloon Inflation

C. Rewire the SB passing through the strut of the MB stent, remove the jailed wire, dilate toward SB, and perform FKB inflation

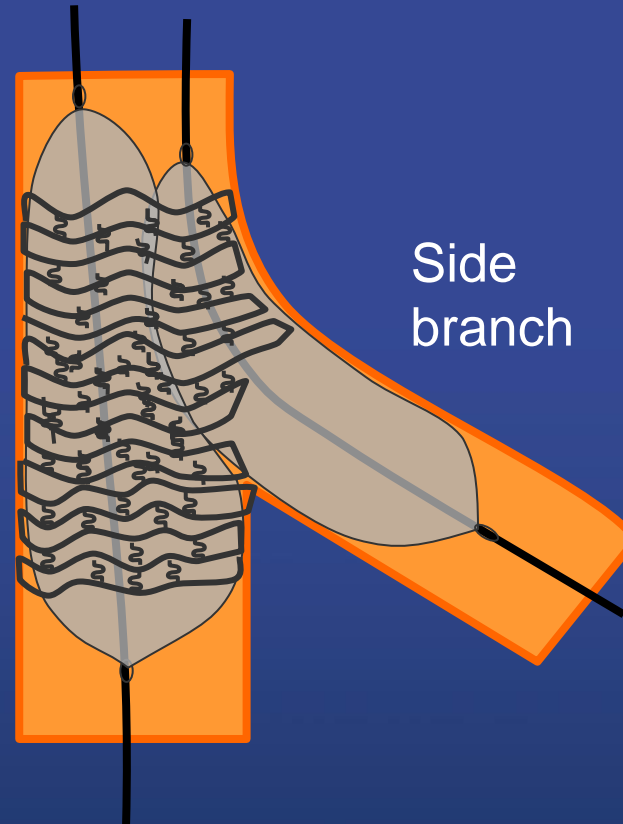

Main branch

Stenting Crossing Side Branch With Optional Kissing Balloon Inflation

D. Final result

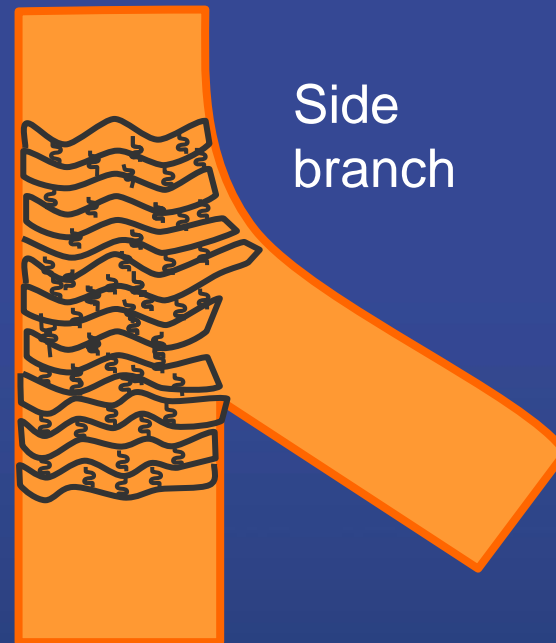

Main vessel

Side
branch

Provisional T Stenting

In cases with significant narrowing of side branch after main branch stenting

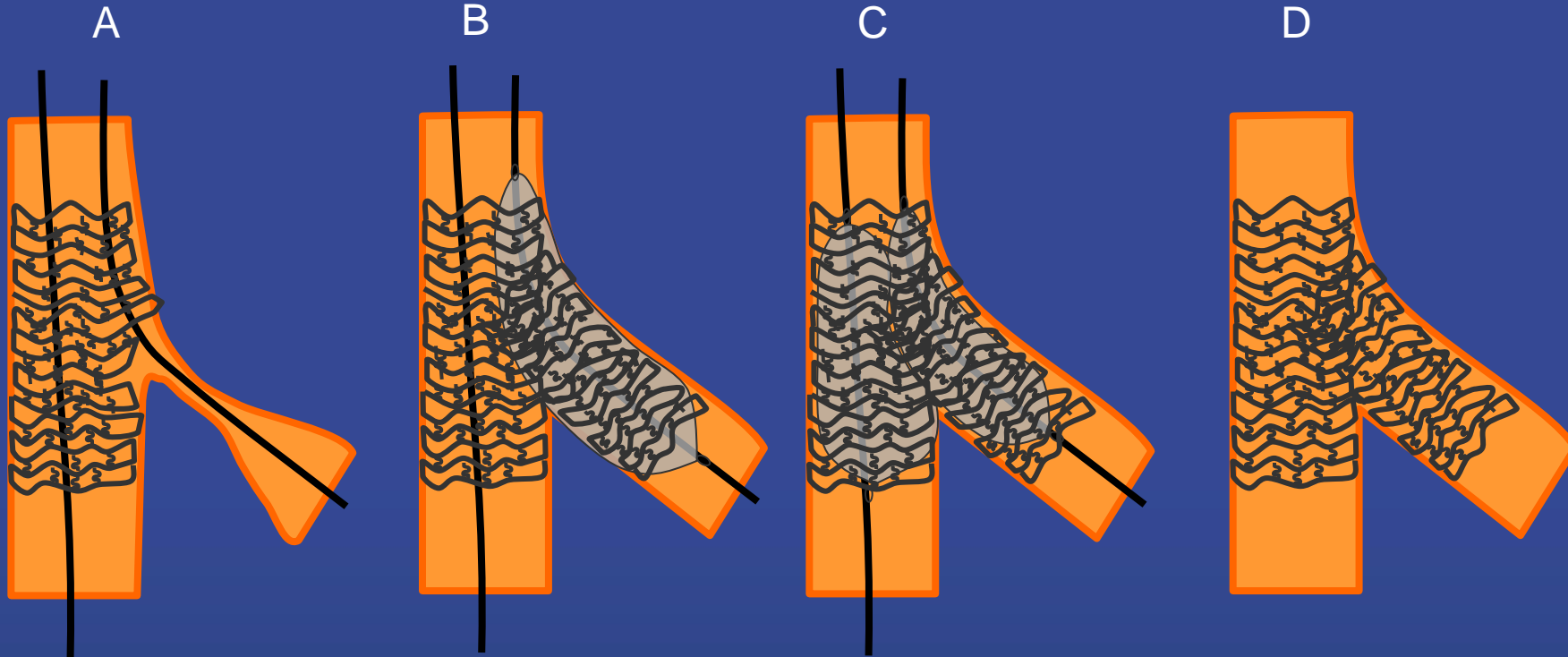

Jailed SB after MB stenting

SB stenting with minimal protrusion

Final kissing is necessary

Slightly protruded stent strut to MB

Advantages

Good SB scaffolding with angles $>70^\circ$

Disadvantages

Potential gap at SB ostium

Protrusion of SB stent into the MB

Provisional T Stenting

In cases with significant narrowing of side branch after main branch stenting

A. Jailed SB after MB stenting

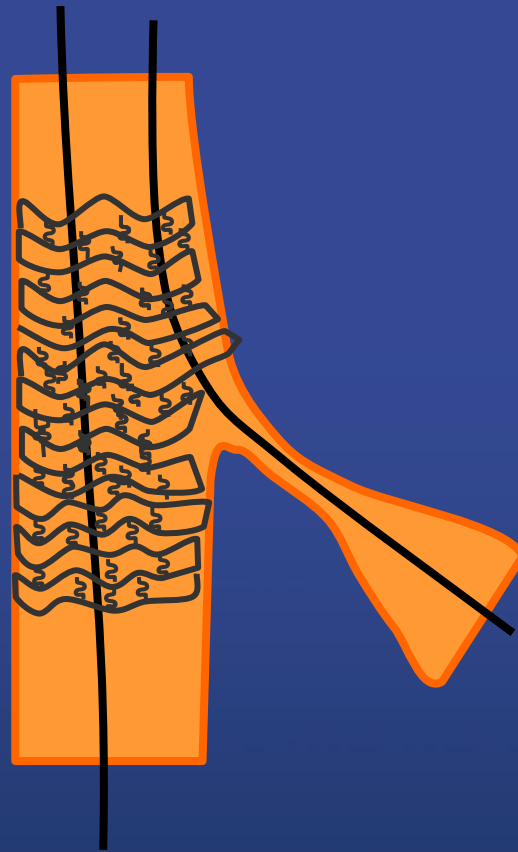

Provisional T Stenting

In cases with significant narrowing of side branch after main branch stenting

B. SB stenting with minimal protrusion

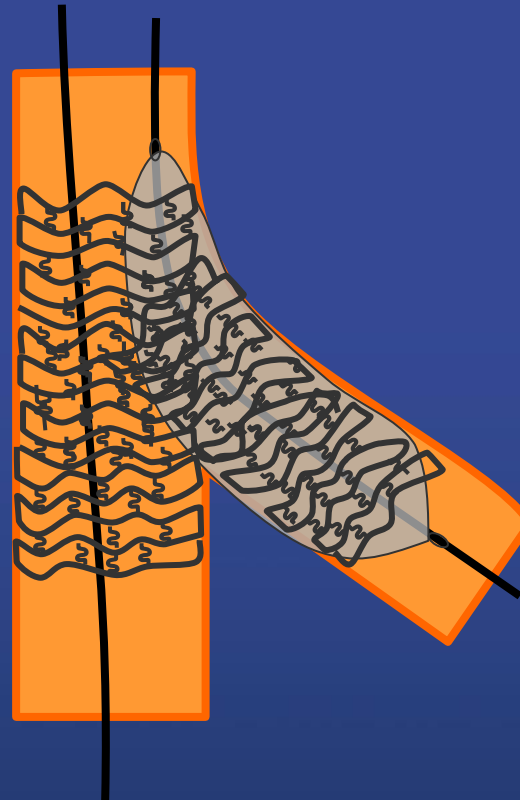

Provisional T Stenting

In cases with significant narrowing of side branch after main branch stenting

C. Final kissing is necessary

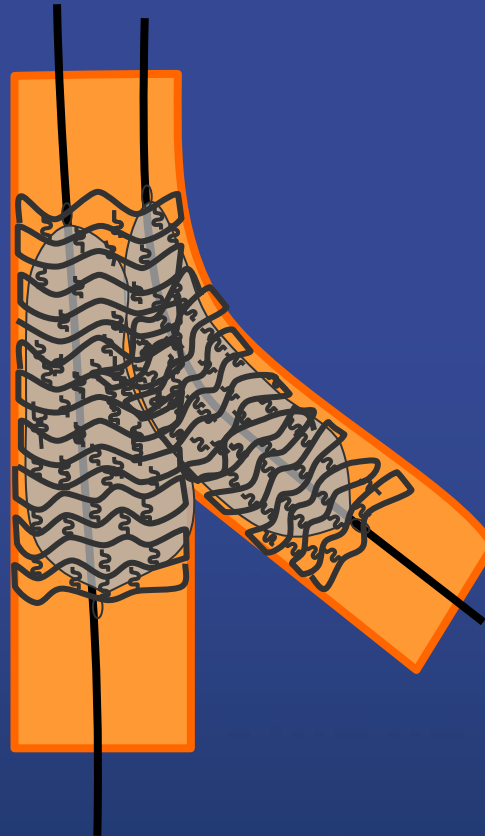

Provisional T Stenting

In cases with significant narrowing of side branch after main branch stenting

D. Slightly protruded stent strut to MB

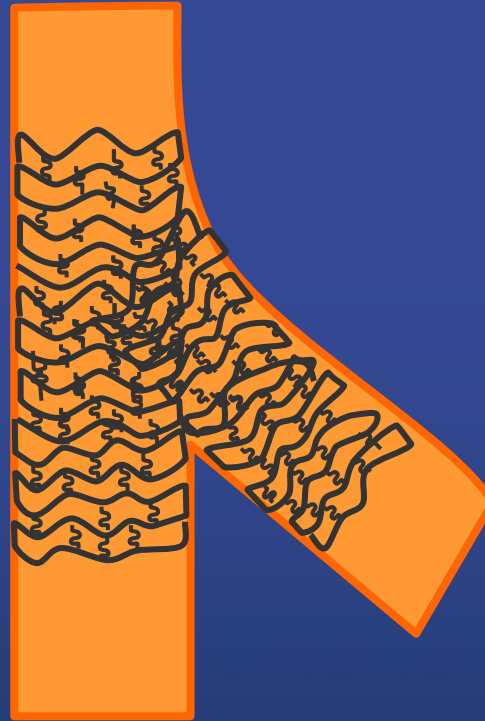

“Internal” or “Reverse” Crush

Final kissing balloon dilatation is mandatory

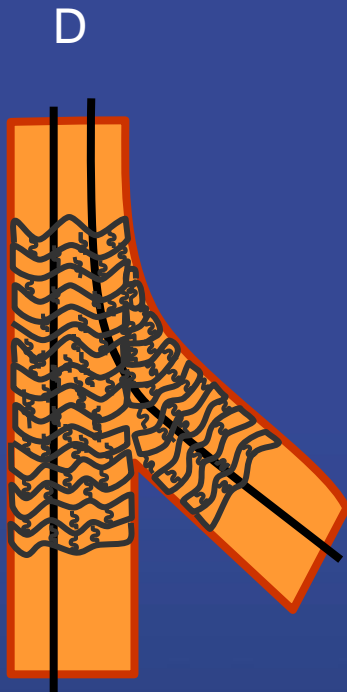

Re-advancement of wire into the side branch



Opening of the side branch ostium

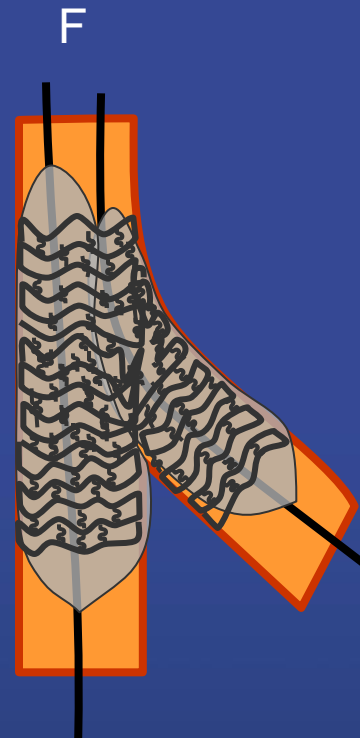

Final kissing balloon inflation

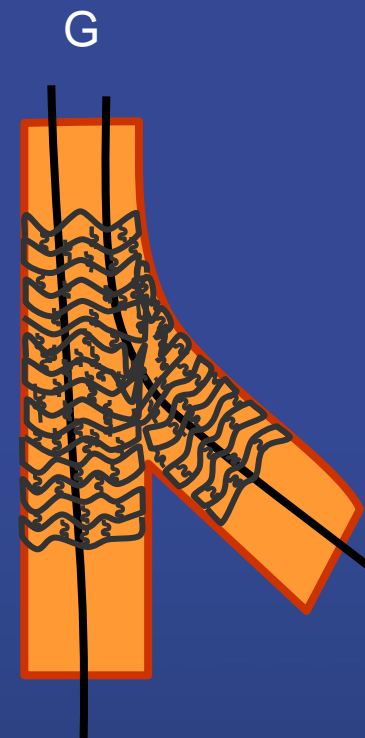

“Internal” or “Reverse” Crush

Final kissing balloon dilatation is mandatory

A. Jailed SB after MB stenting

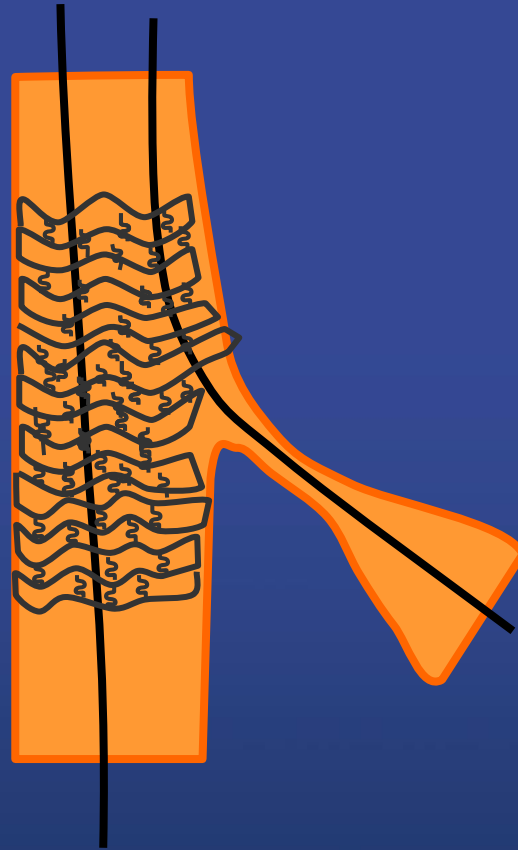

“Internal” or “Reverse” Crush

Final kissing balloon dilatation is mandatory

B. SB stenting with minimal protrusion

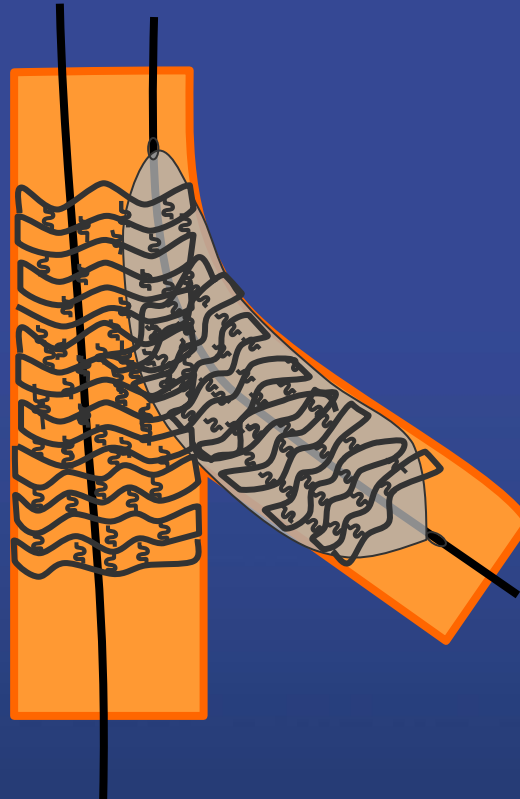

“Internal” or “Reverse” Crush

Final kissing balloon dilatation is mandatory

C. Remove SB balloon & wire,
and inflate MB at high pressure to crush SB stent

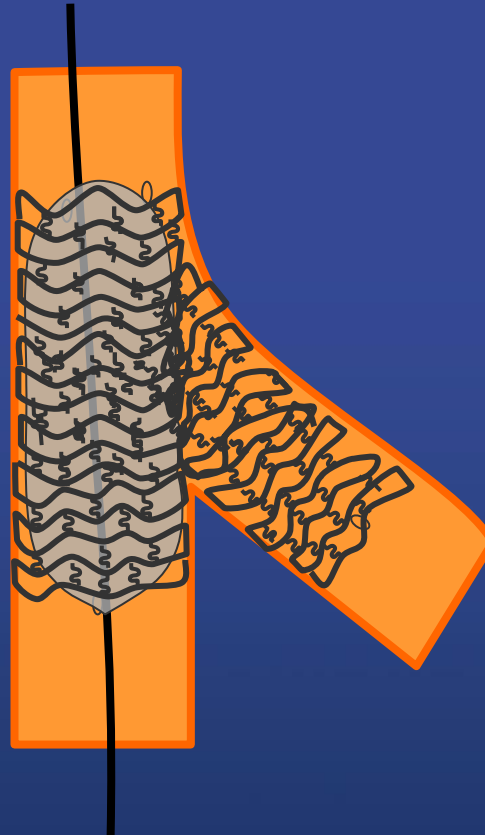

“Internal” or “Reverse” Crush

Final kissing balloon dilatation is mandatory

D. Re-advancement of wire into the side branch

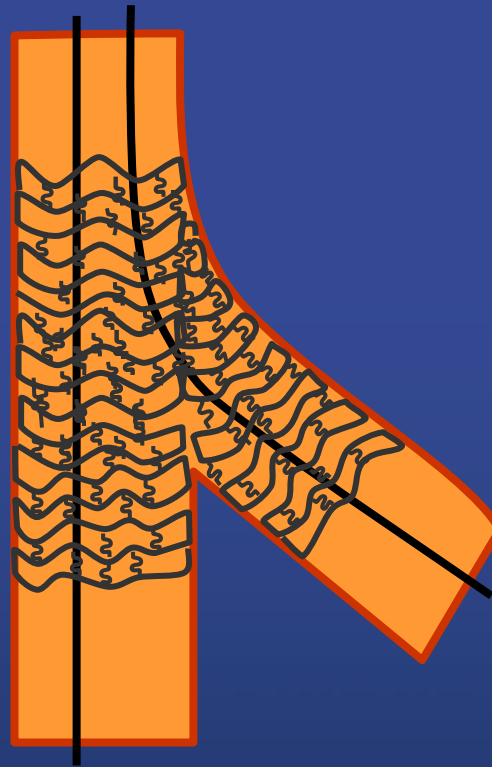

“Internal” or “Reverse” Crush

Final kissing balloon dilatation is mandatory

E. Opening of the side branch ostium

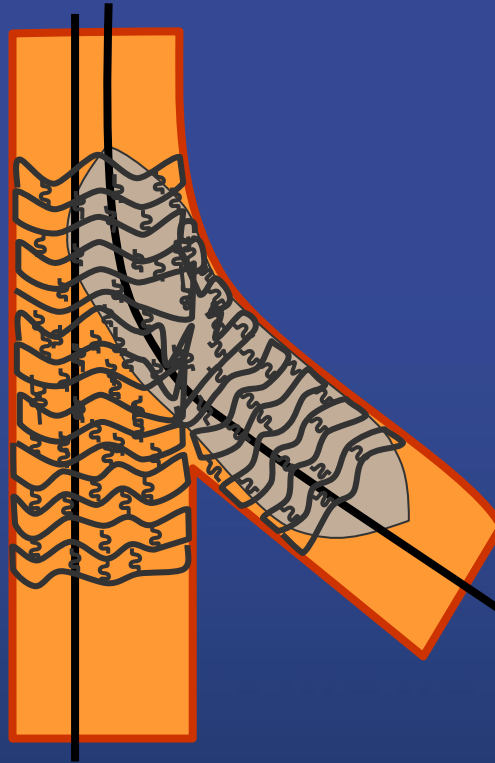

“Internal” or “Reverse” Crush

Final kissing balloon dilatation is mandatory

F. Final kissing balloon inflation

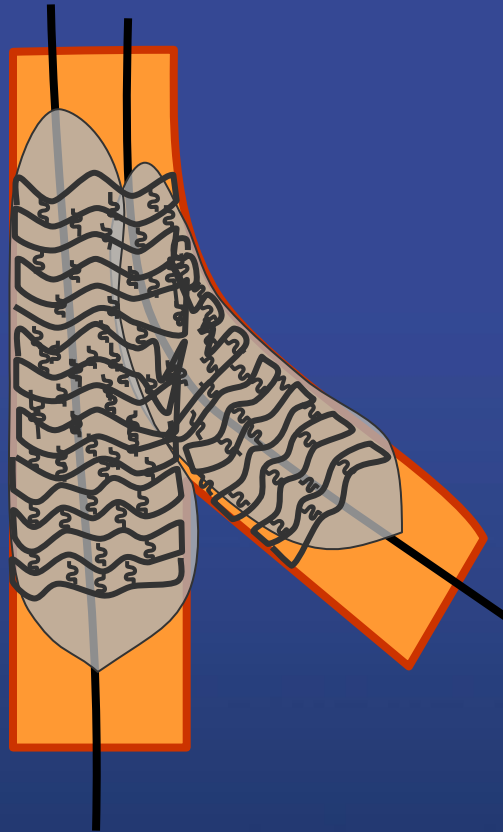

“Internal” or “Reverse” Crush

Final kissing balloon dilatation is mandatory

G. Final result

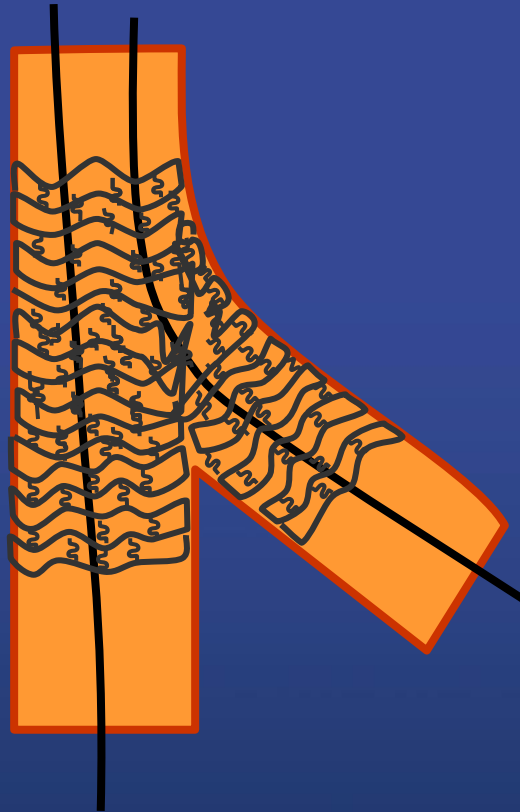

Y (Culotte) Stenting

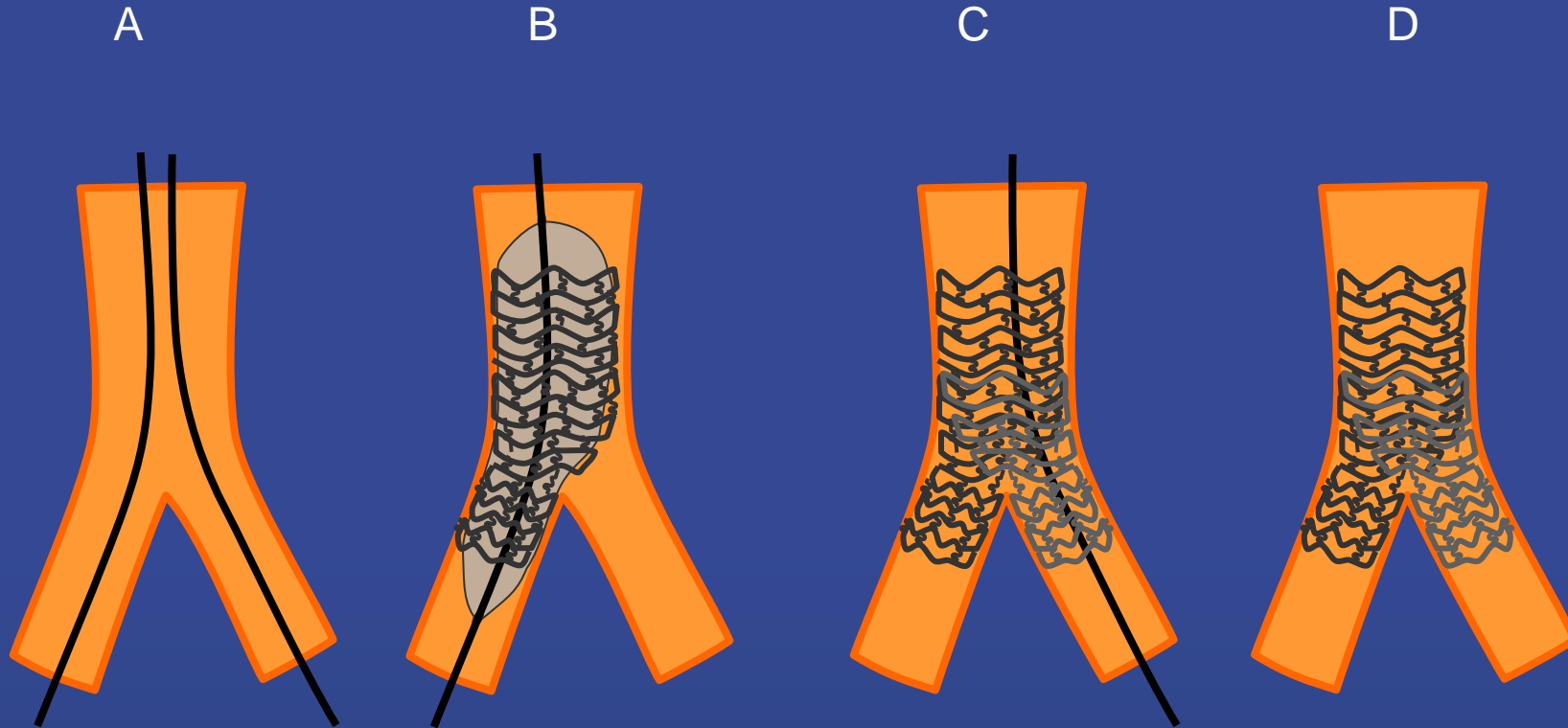

Advantages

Compatible with 6-Fr guider
Independent of bifurcation angle
Predictable scaffolding

Disadvantages

Leaves multiple layers of strut
Potential acute closure of MB

Y (Culotte) Stenting

A. Wire both branches and predilate if needed

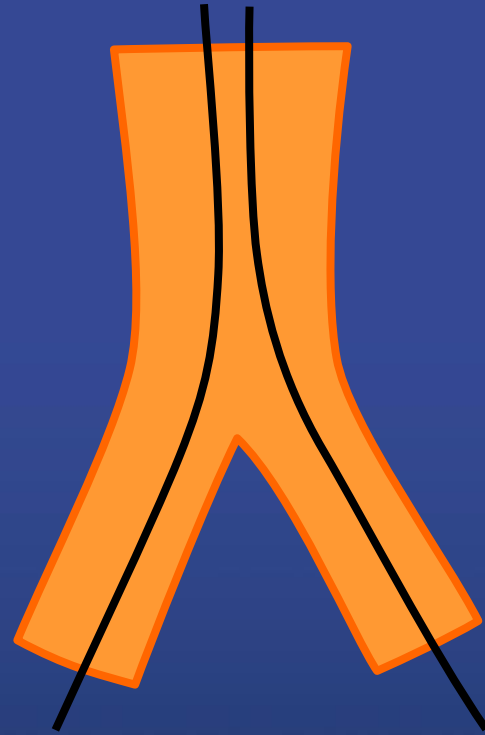

Y (Culotte) Stenting

B. Deploy a stent in the more angulated branch (SB)

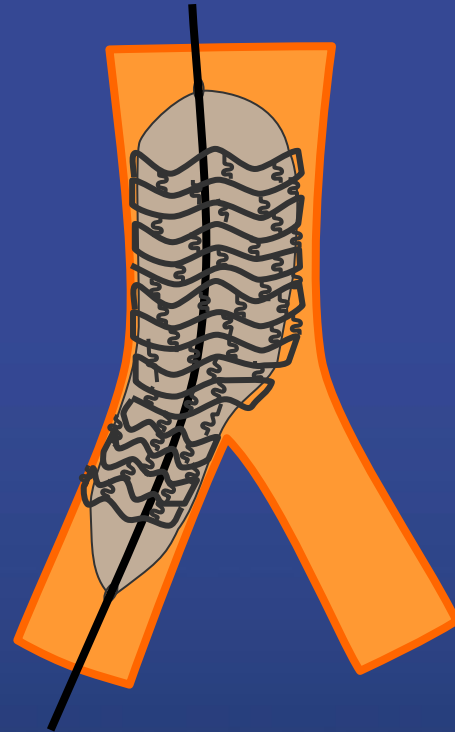

Y (Culotte) Stenting

C. Rewire unstented branch, dilate the stent to unjail the MB, and expand a second stent into the unstented MB

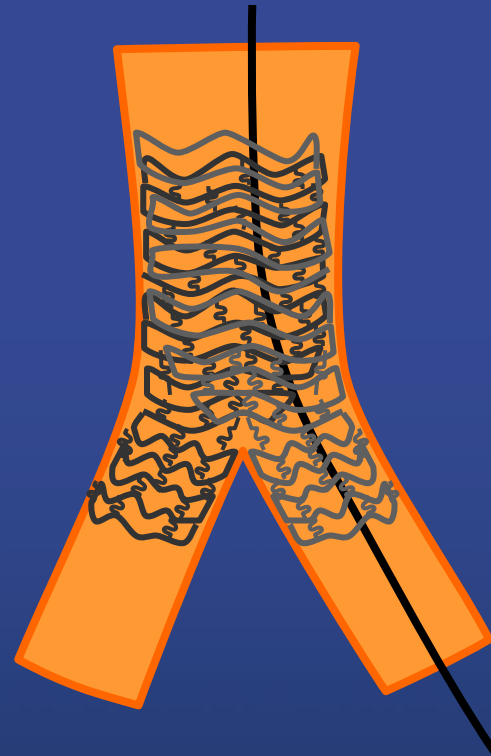

Y (Culotte) Stenting

D. Final result after final kissing balloon

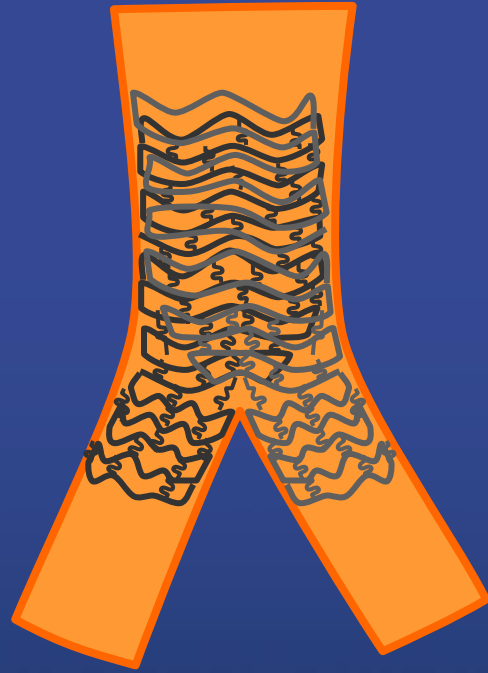

Modified T-Stenting

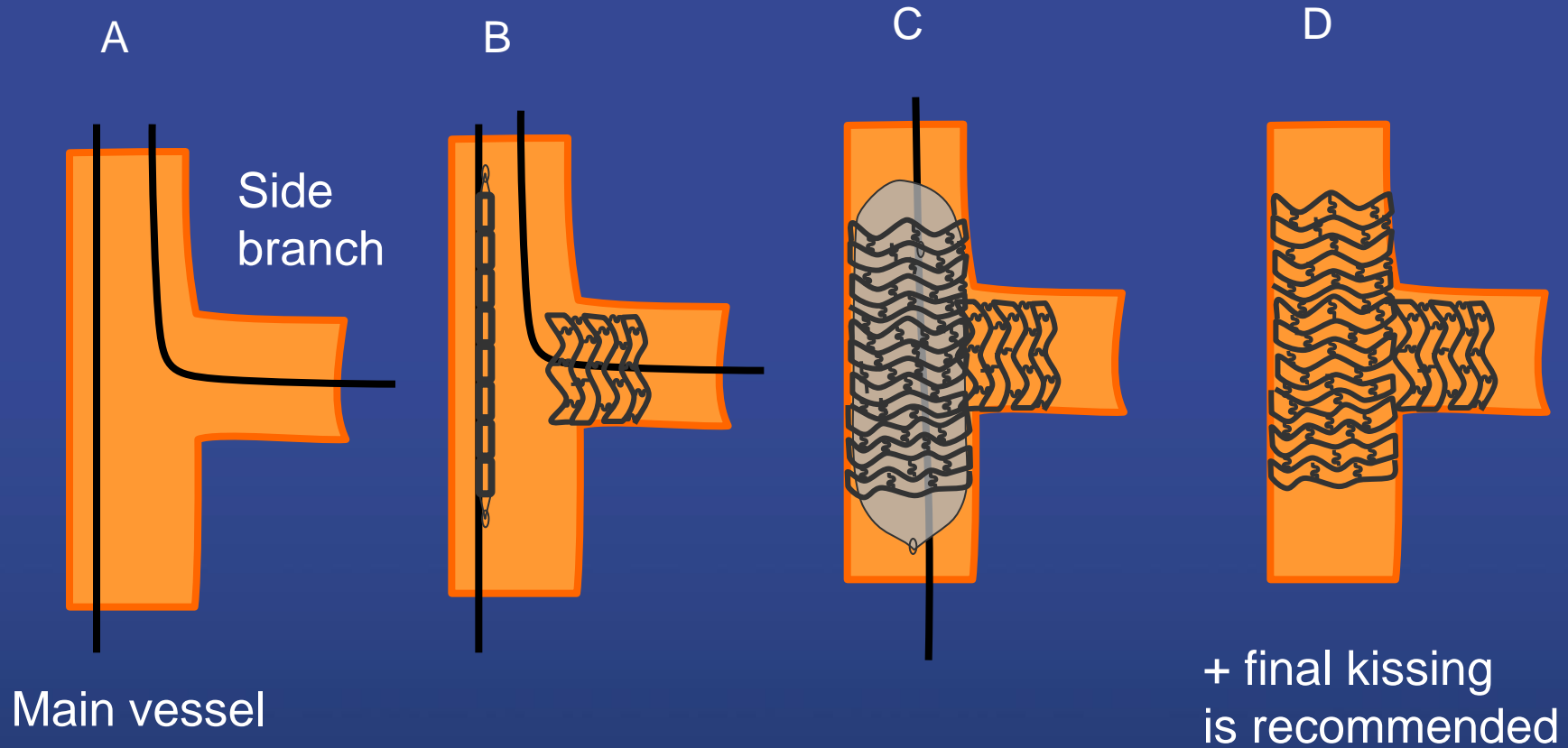

Modified T-Stenting

A. Wire both branches and predilate if needed

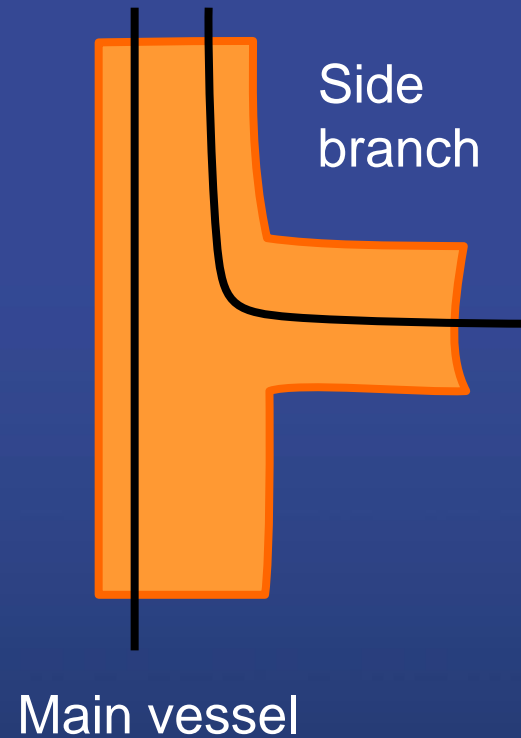

Modified T-Stenting

B. SB stent deployed at nominal pressure

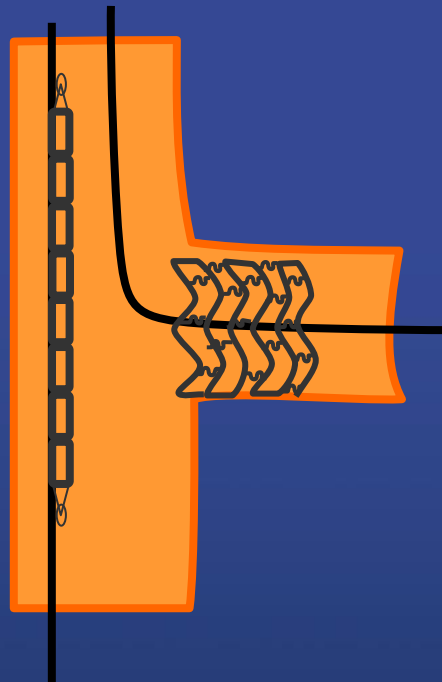

Modified T-Stenting

C. Remove balloon and wire from SB,
And deploy the MB stent at high pressure

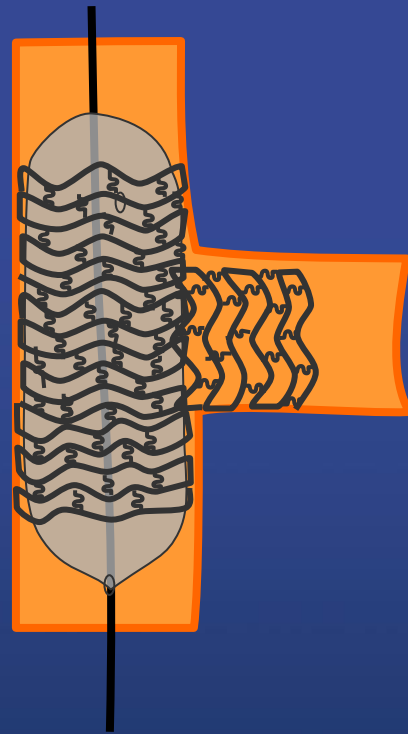

Modified T-Stenting

D. Rewire the SB and high-pressure dilatation, then final kissing inflation is recommended

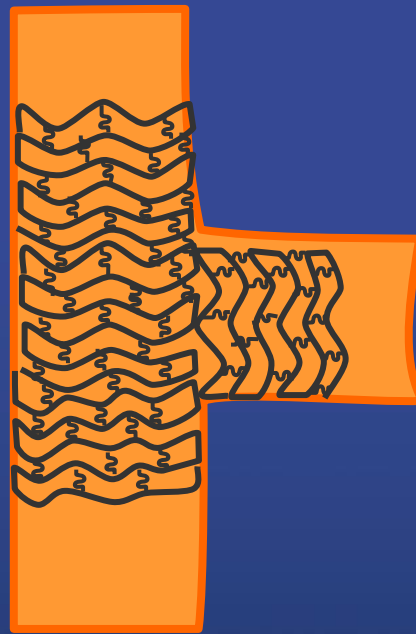

Limitation of Modified T Stenting

Restenosis site of T stenting in SIRIUS bifurcation

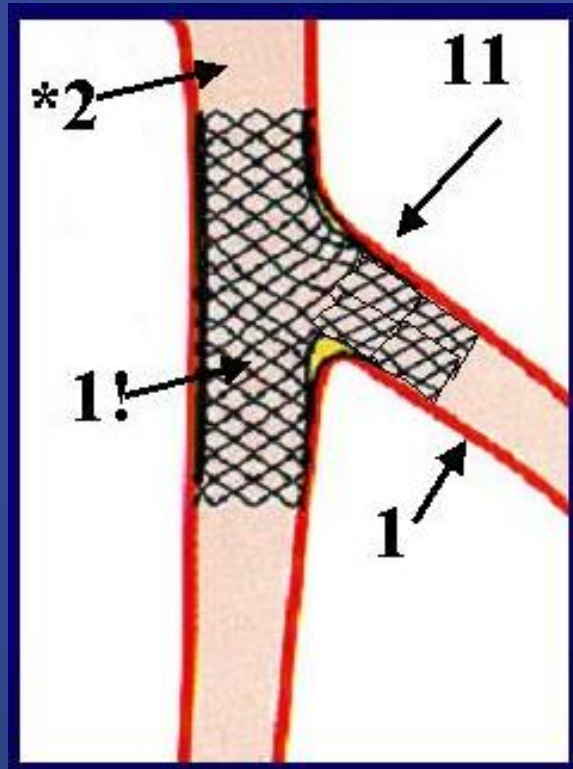

Potential gap without enough drug diffusion

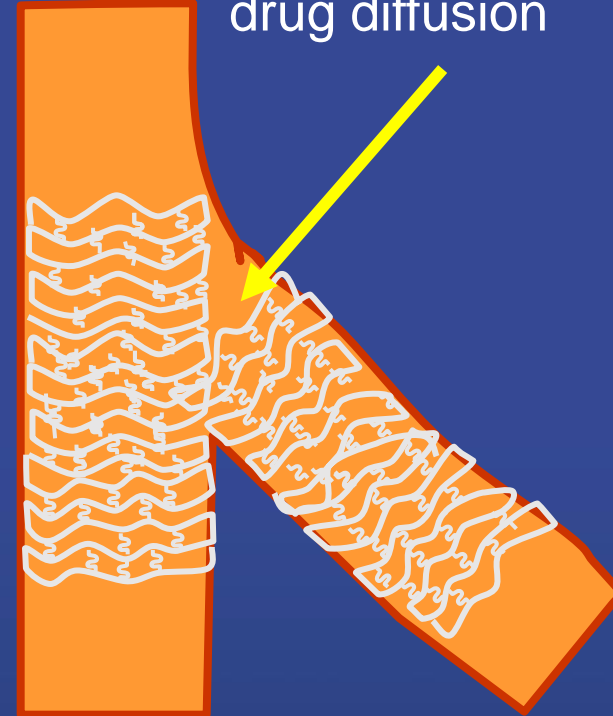

To prevent potential gap at the ostial side branch, the first stent should cover the entire surface of the side branch.

Modified T-Stenting

For Proper Ostial positioning

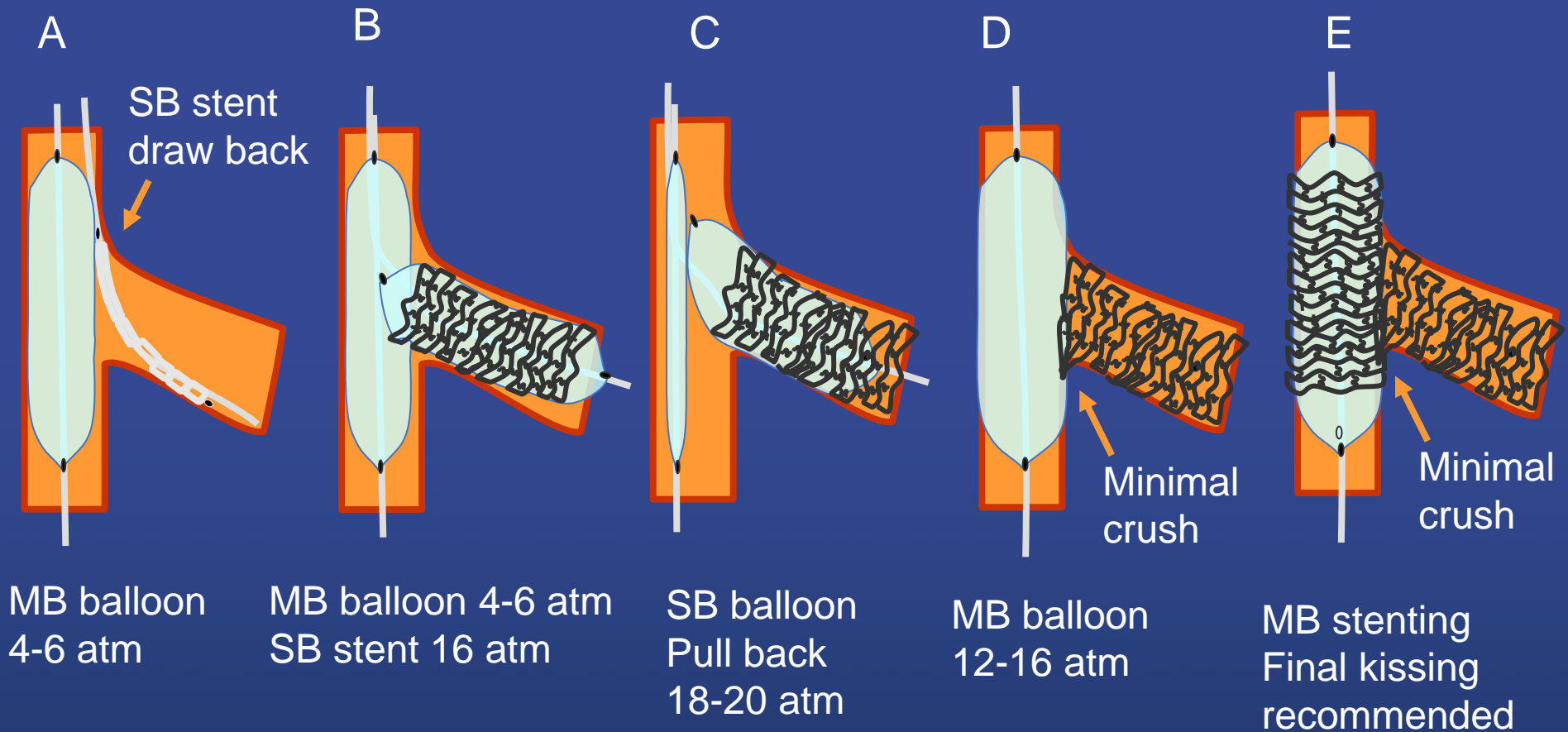

Crush Technique

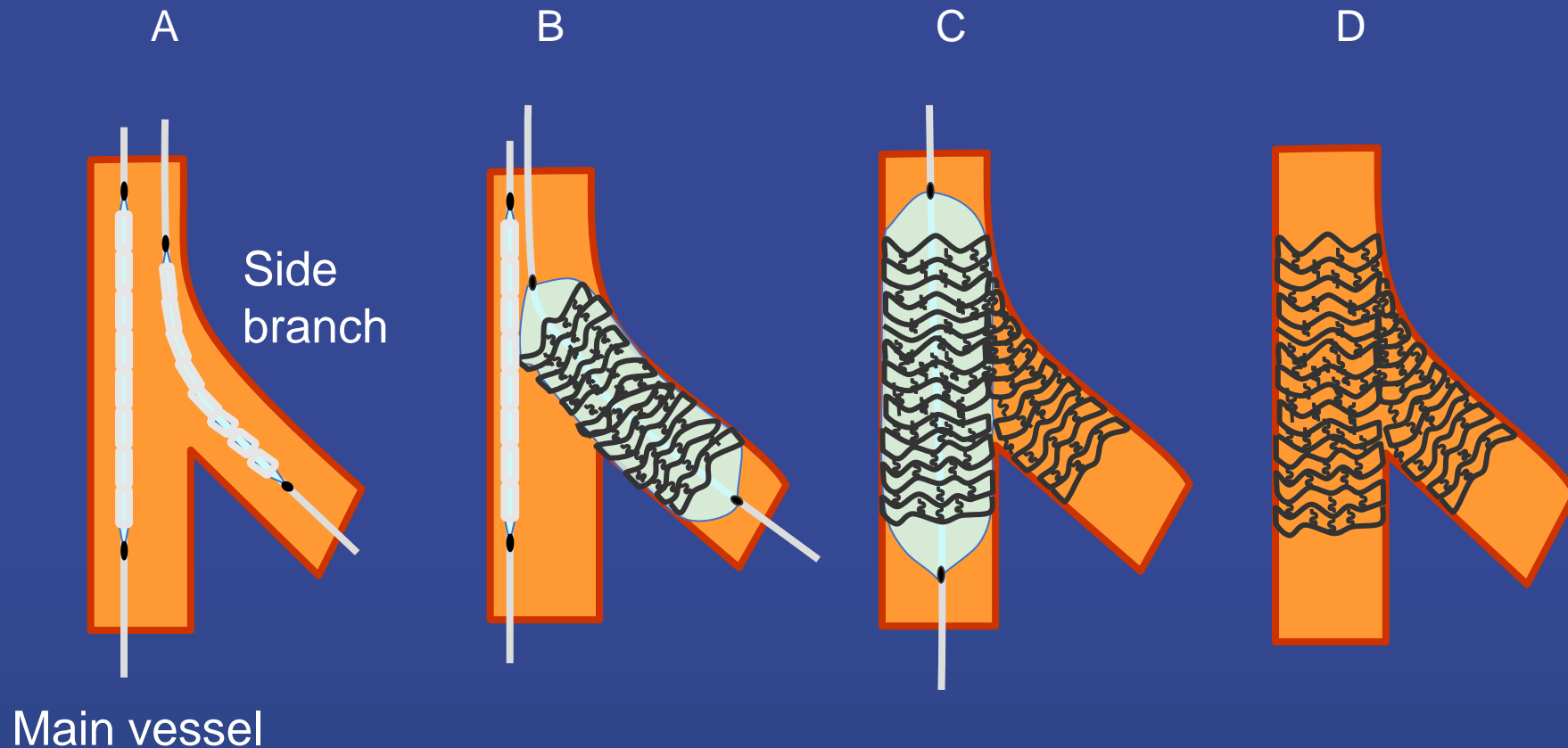

Advantages

- Relatively simple
- Low risk of SB occlusion
- Good coverage of SB ostium

Disadvantages

- Difficult FKI
- Requires 7 or 8-Fr guider
- Leaves multiple layers of strut

Crush Technique

A. Advance 2 stents

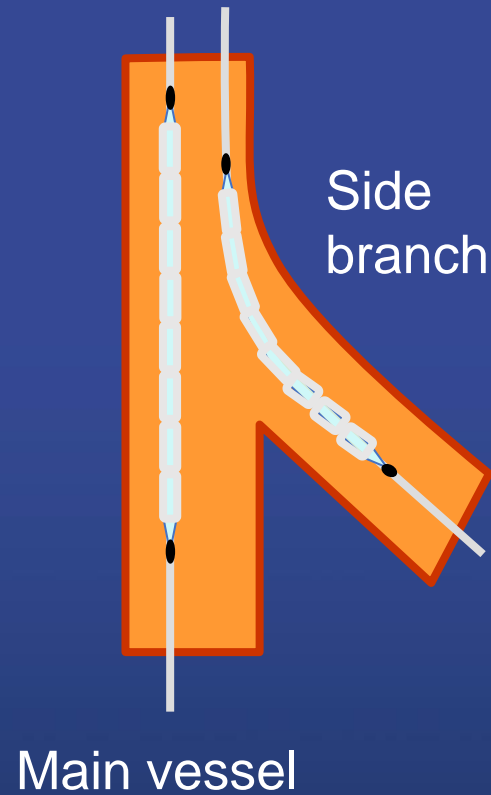

Crush Technique

B. Deploy the SB stent

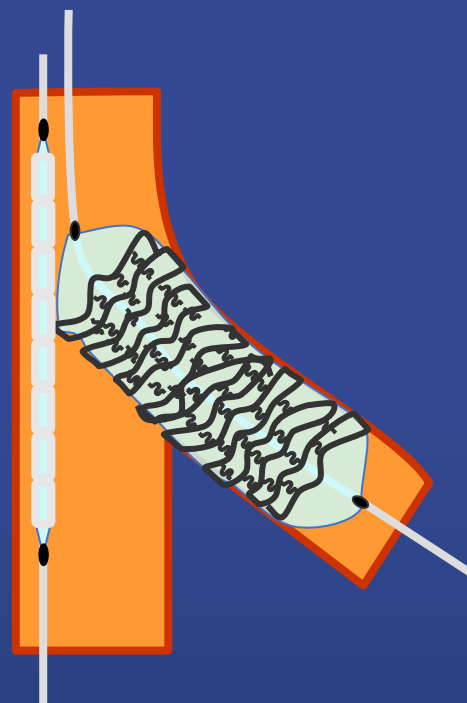

Crush Technique

C. Deploy the main stent,
then rewire SB and perform high-pressure dilatation

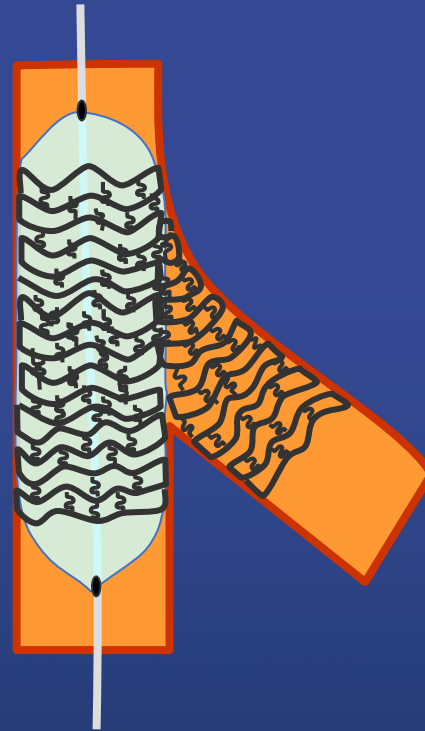

Crush Technique

D. Perform final kissing inflation

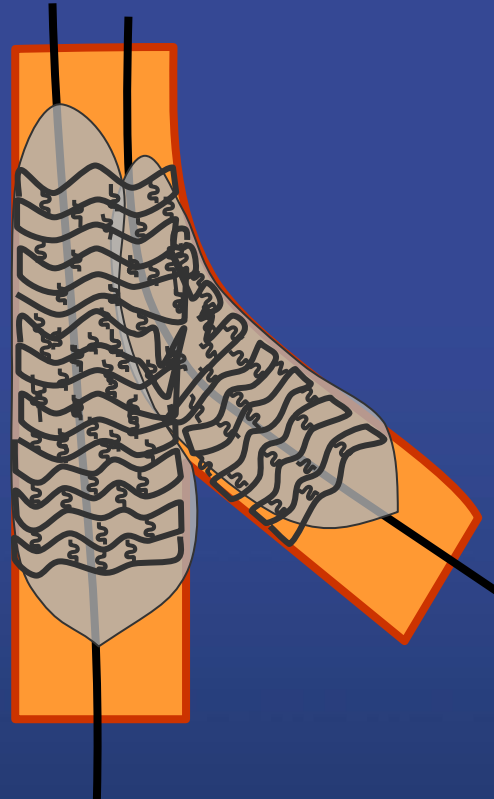

Crush Technique

D. Final result

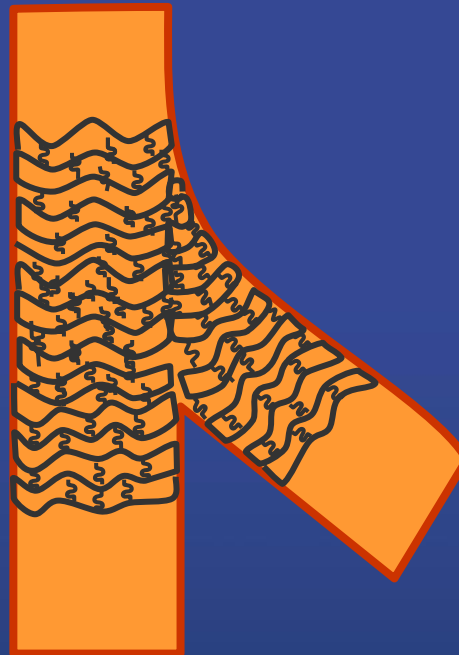

Mini-Crush with balloon

Performed with 6~7Fr guiding catheter

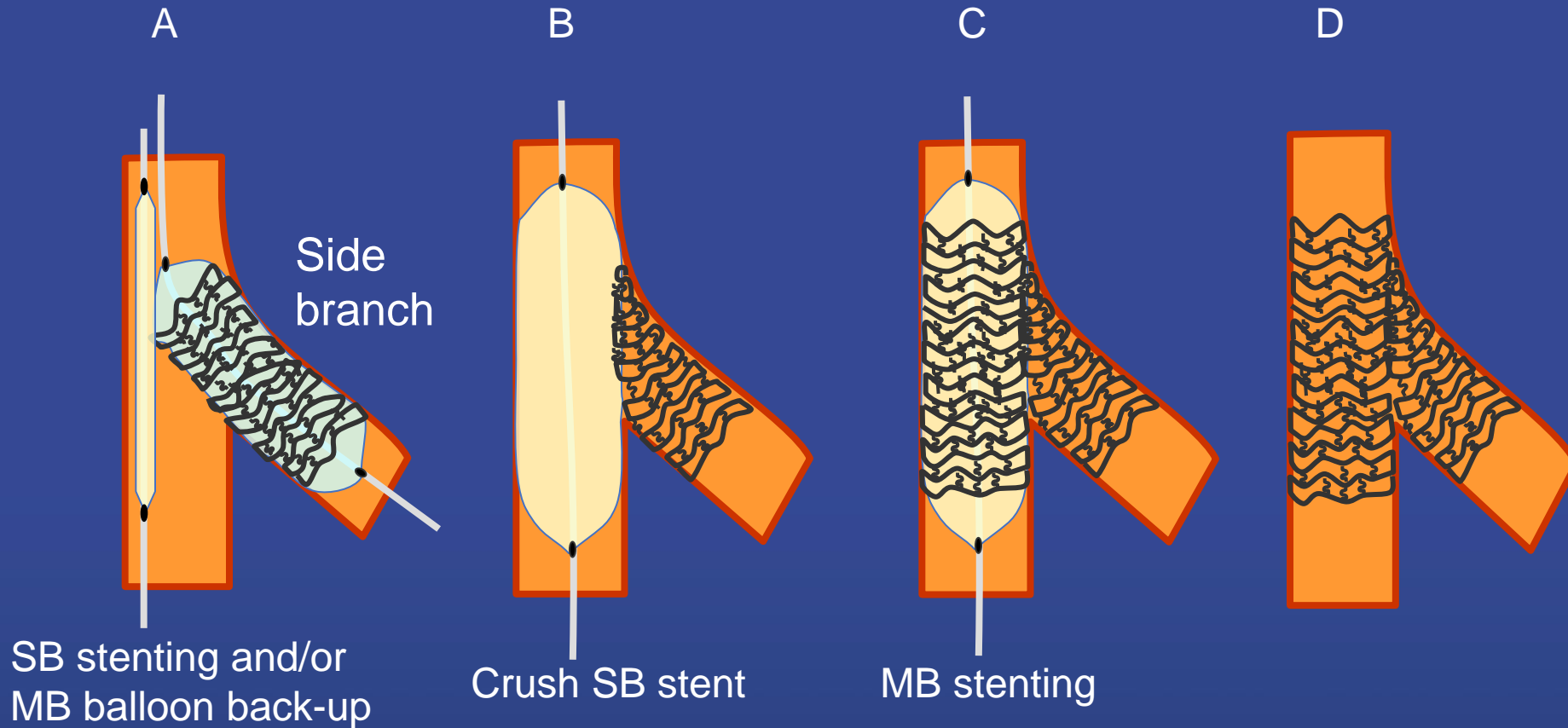

Advantages

- Minimizes multi-layers of struts
- Good scaffolding at SB ostium
- Facilitates FKI
- Compatible with 6-Fr guider

Disadvantages

- Still leaves multiple layers of strut

Mini-Crush with balloon

Performed with 6~7Fr guiding catheter

A. Deploy the SB stent \pm MB balloon backup

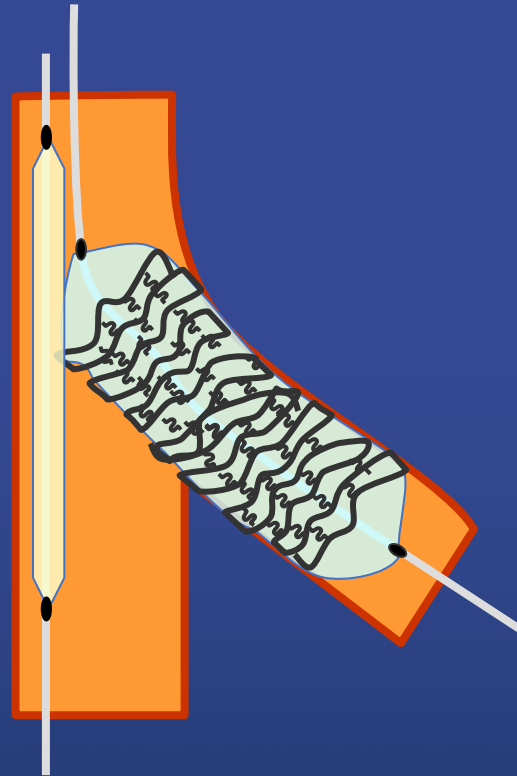

Mini-Crush with balloon

Performed with 6~7Fr guiding catheter

B. Crush SB stent

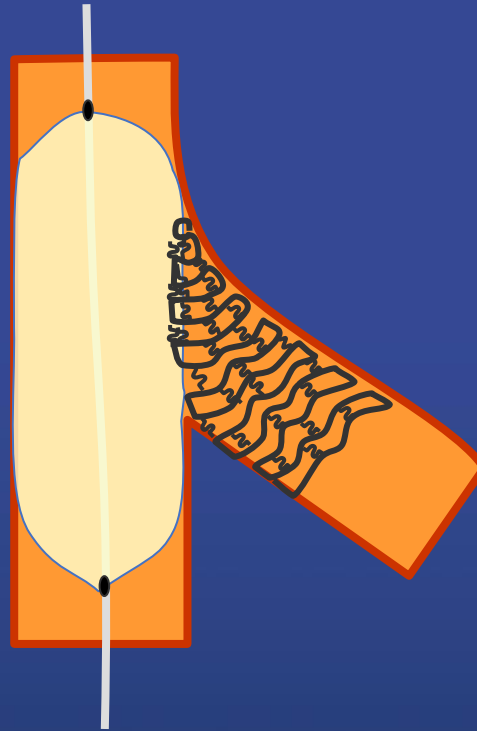

Mini-Crush with balloon

Performed with 6~7Fr guiding catheter

C. Deploy stent in MB,
then rewire SB and perform high-pressure dilatation

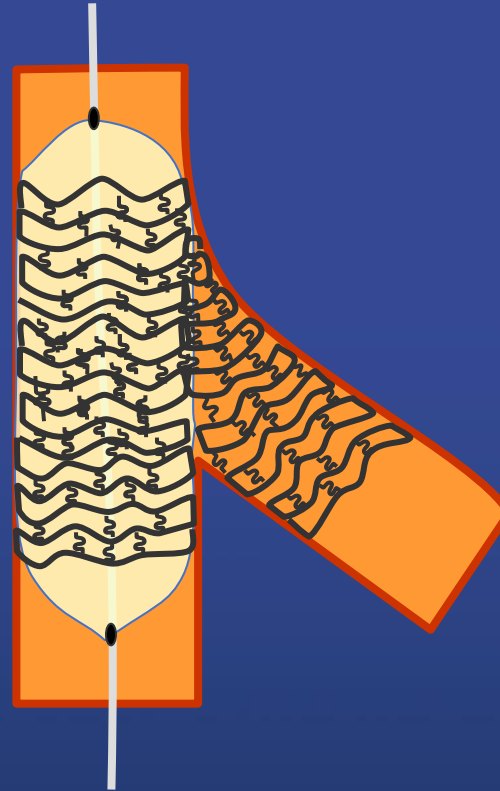

Mini-Crush with balloon

Performed with 6~7Fr guiding catheter

E. Perform final kissing inflation

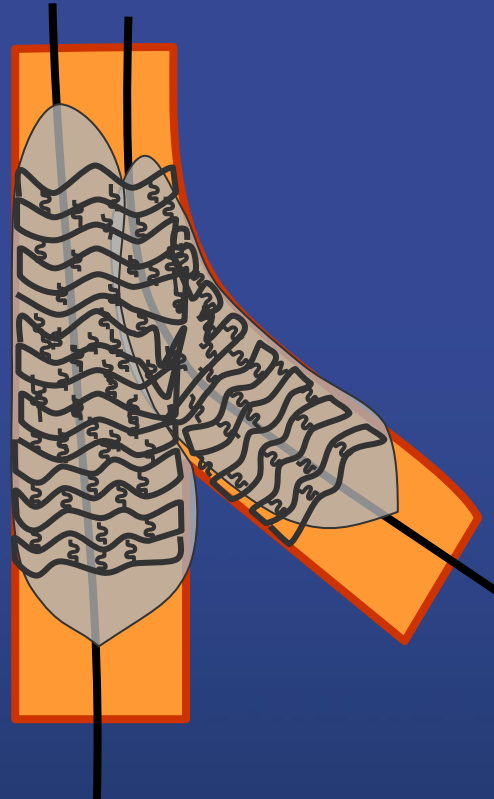

Mini-Crush with balloon

Performed with 6~7Fr guiding catheter

F. Final result

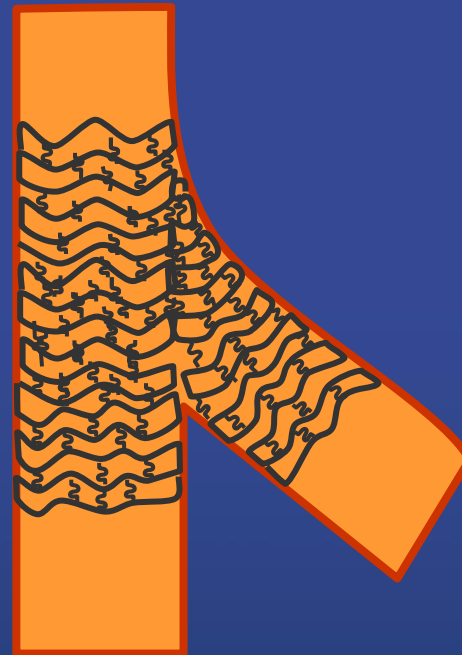

V Stenting

- Bifurcation without stenosis proximal to the bifurcation
- Short LM
- Less angle

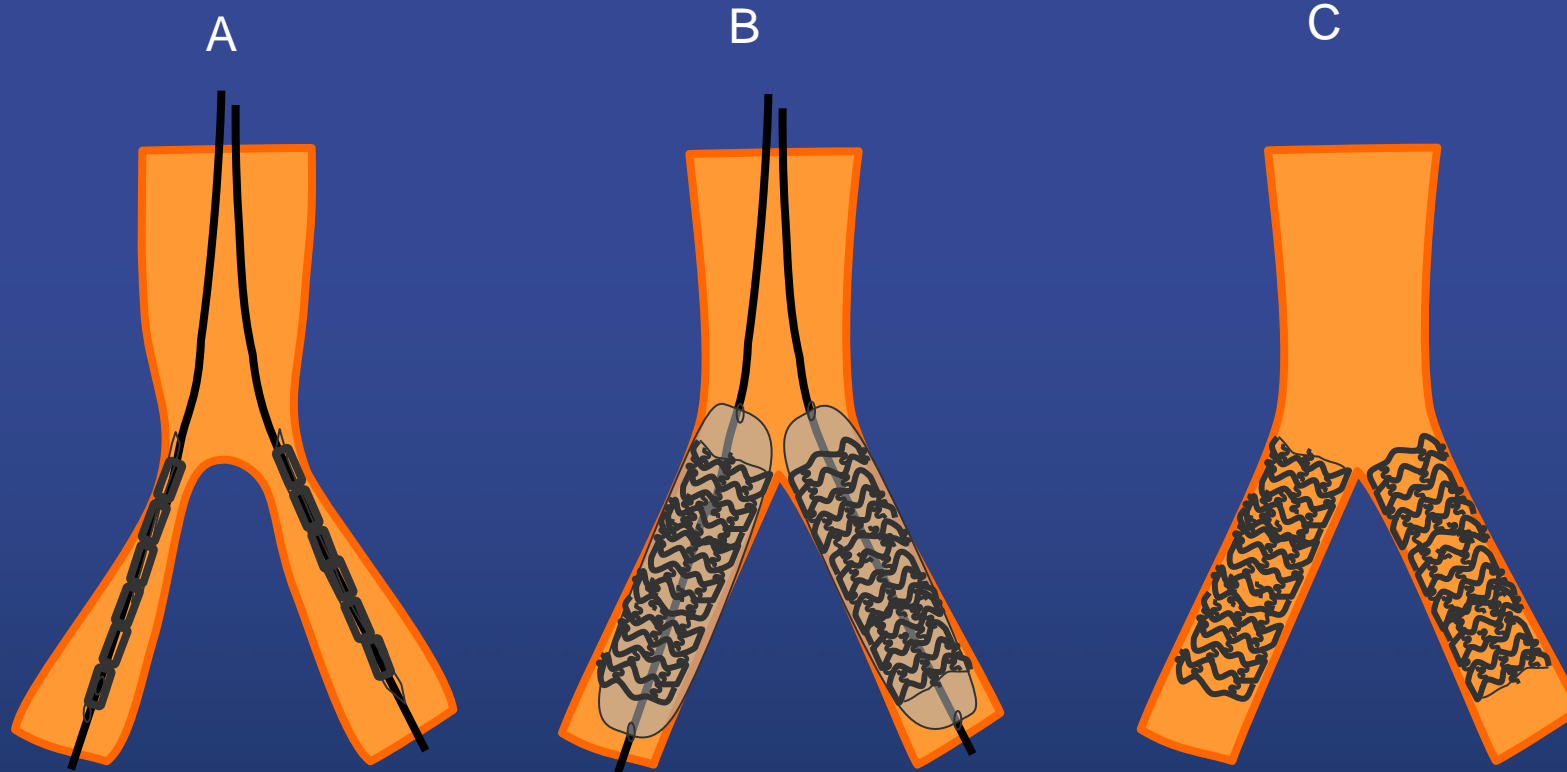

V Stenting

- A. Position 2 parallel stents covering both branches with a slight protrusion into the proximal MB

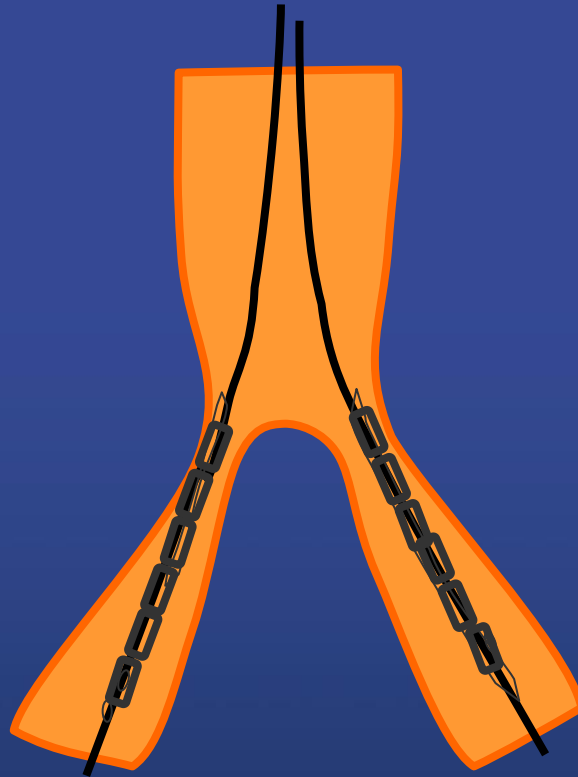

V Stenting

B. Deploy 2 stents individually (or simultaneously)

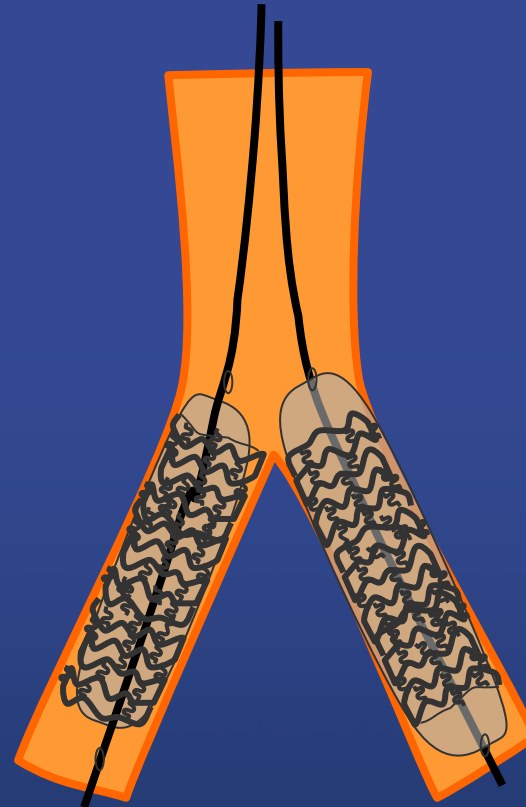

V Stenting

C. Perform high-pressure sequential single stent postdilation,
Then medium pressure final kissing inflation

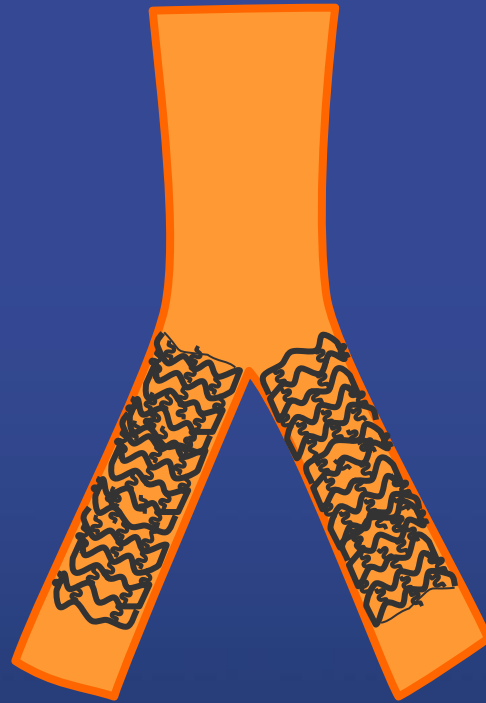

Simultaneous Kissing Stenting

- Large proximal reference
- Bifurcation with stenosis proximal to the bifurcation

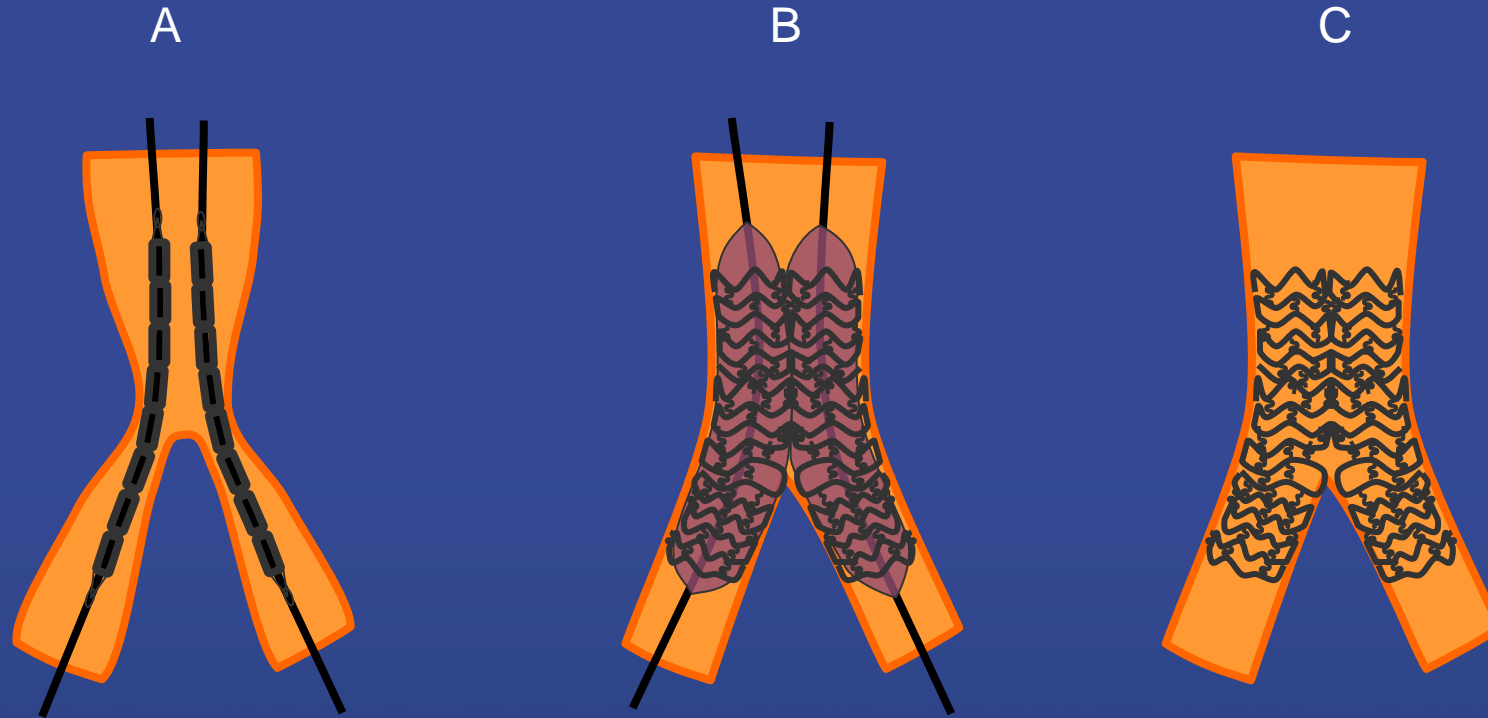

Advantages

No risk of occlusion for both branches
No need to re-cross any stent
Technically easy and quick

Disadvantages

Requires 7- or 8-Fr guider
Leaves long metallic carina
Over-dilatation in proximal MB
Diaphragmatic membrane formation
Difficulty in repeat revascularization

Simultaneous Kissing Stenting

A. Position 2 parallel stents covering both branches with a long double barrel protrusion into the proximal MB

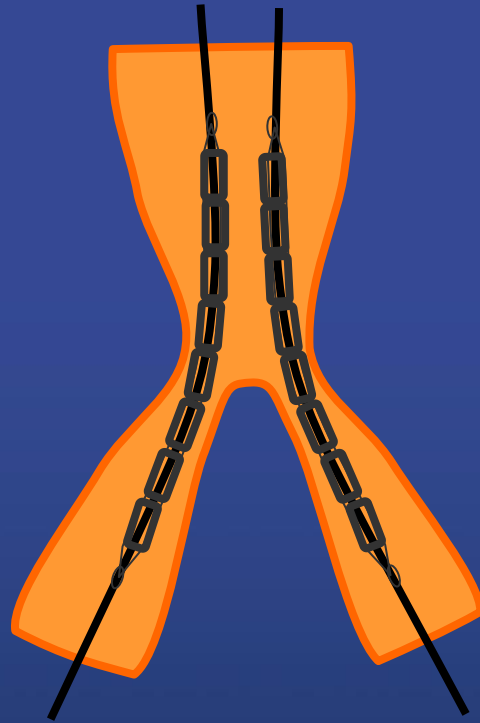

Simultaneous Kissing Stenting

B. Deploy 2 stents

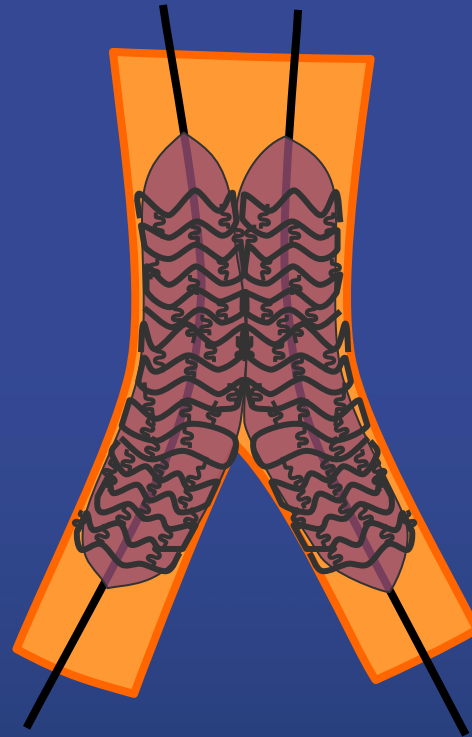

Simultaneous Kissing Stenting

C. Perform final kissing inflation resulting a new metallic carina



IVUS in LM disease

IVUS Use was Associated with Better 10-yr Outcomes after LM PCI

MAIN-COMPARE Registry

Left Main Disease



10-Year
Follow-up



IVUS-guided PCI

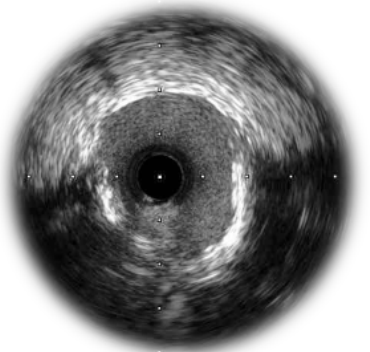

IVUS guidance associated with better outcome in LMCA stenting compared with angiography guidance alone

SCAAR Registry

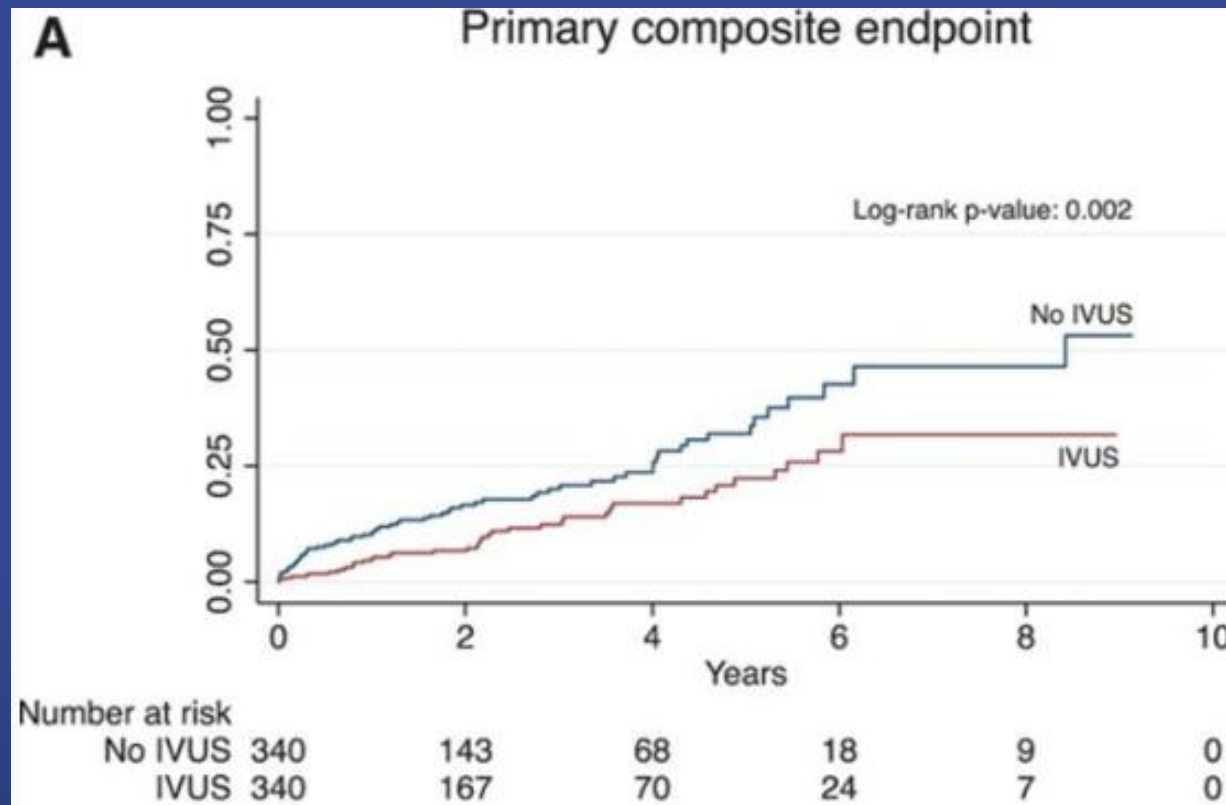

Pooled analysis

:ESTROFA-LM, RENACIMIENTO, Bellvitge, Valdecilla

Effectiveness of IVUS on LM PCI

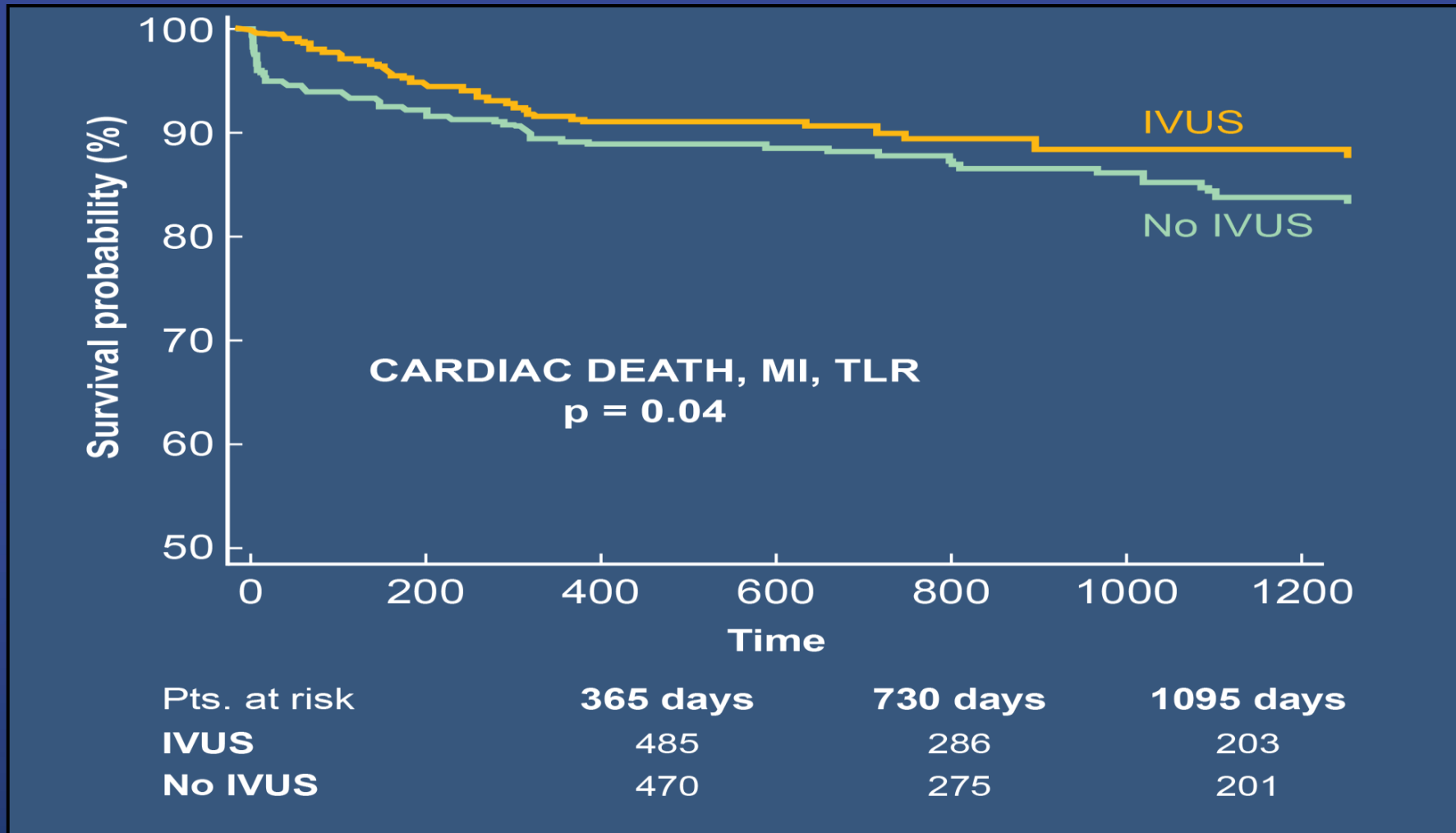



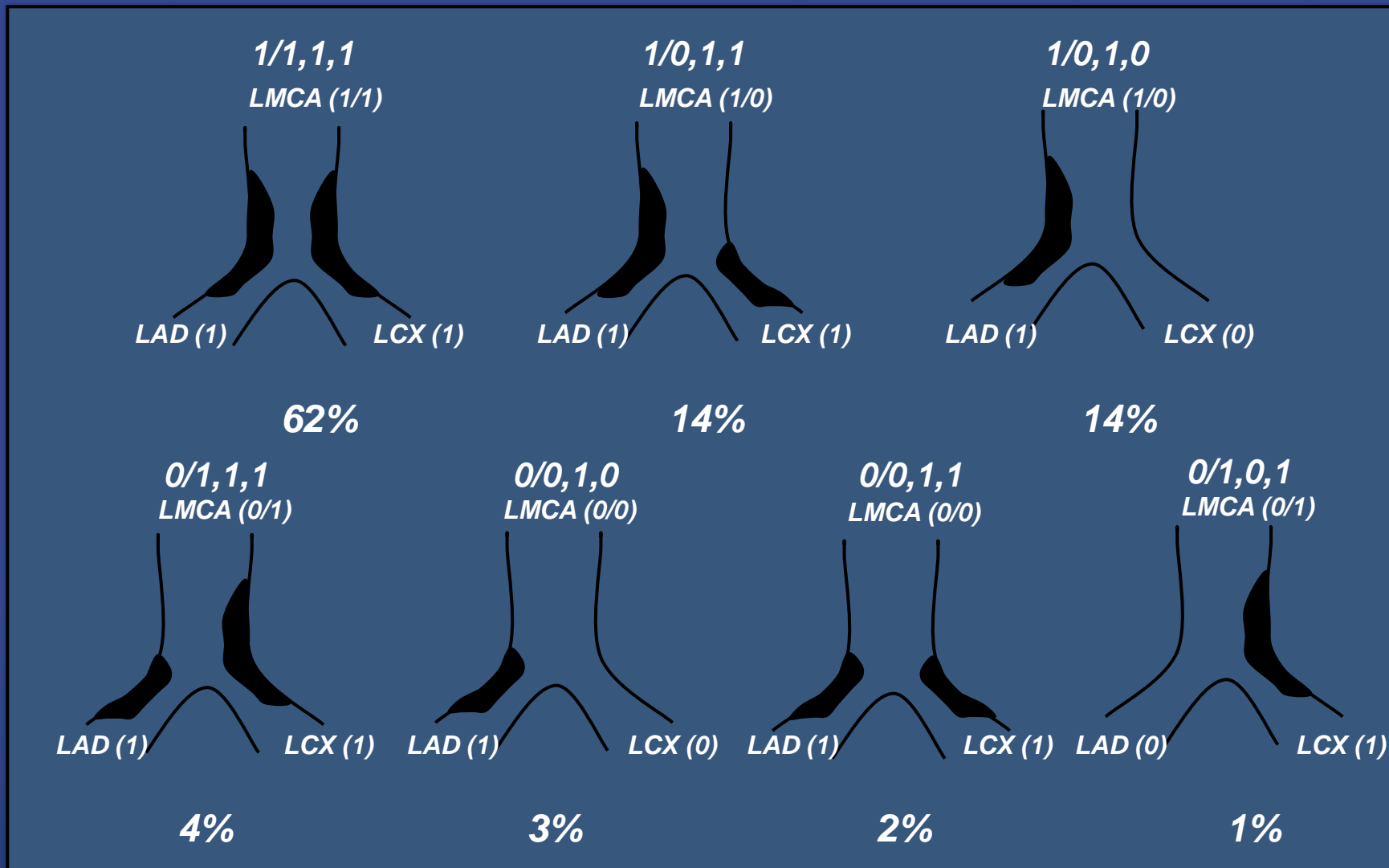

Plaque Distribution by IVUS (n=140)

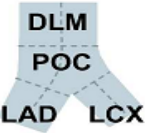

In 90% plaque extends from LMCA-LAD

Oviedo C et al. Circ Cardiovasc Interv 2010;3:105-12.

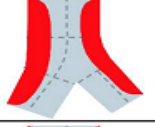
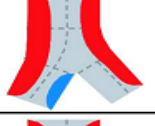
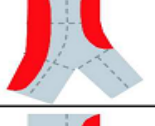
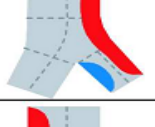
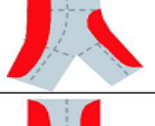
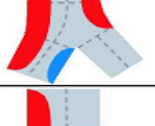
Plaque Distribution by IVUS (n=82)

	N. (%)	LAD ostium, MLA (mm ²)	POC, MLA (mm ²)	DLM, MLA (mm ²)	LCX ostium, MLA (mm ²)
	5 (6%)	4.4±2.0	9.6±4.4	8.1±4.7	3.4±1.6
	26 (32%)	4.2±2.8	5.3±2.6	4.6±1.5	3.9±2.1
	12 (15%)	2.6±1.3	4.5±1.6	4.5±2.1	3.3±2.0
	9 (11%)	4.3±2.5	5.6±3.3	5.7±3.8	7.6±3.6
	9 (11%)	3.2±1.4	6.1±2.0	4.8±2.5	3.9±1.4
	4 (5%)	3.4±1.9	5.2±1.9	5.8±4.7	3.9±2.0
	4 (5%)	2.8±0.7	5.1±2.1	5.1±2.2	6.6±1.7
	5 (6%)	3.4±1.9	5.2±2.6	5.1±3.8	4.6±2.1

In all cases, the LM disease extended into LAD and LCX continuously.

Optimal MSA

on a segmental basis

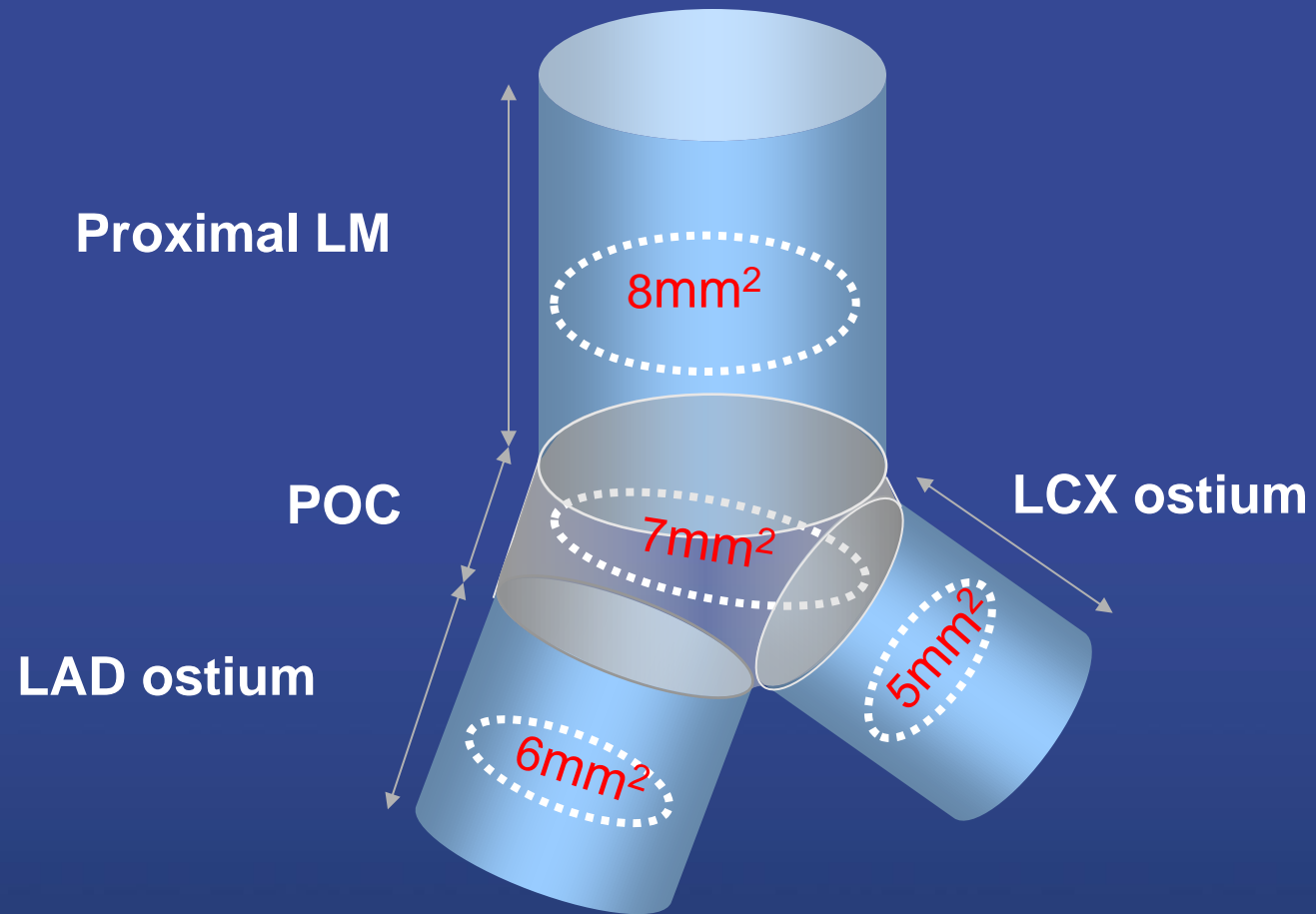

Cut-off for Predicting LM FFR<0.75 : LM MLA 6.0mm²

- Sum of lumen areas of two daughter vessels (Each of LAD and LCx should be 4.0mm²) = 150% of the parent LM
- Murray's Law ($LM r^3 = LAD r^3 + LCx r^3$)

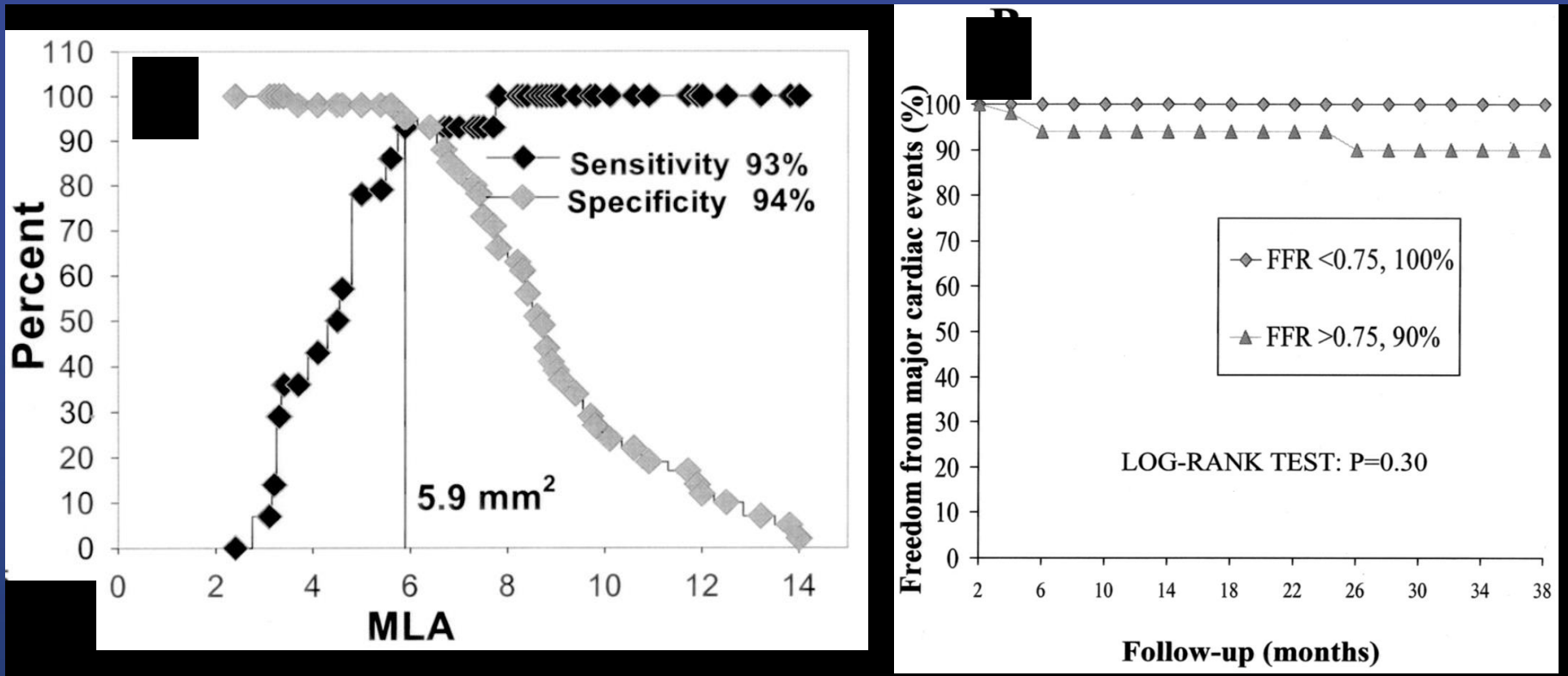

Geometric Abstraction

Old MLA cut-off 6.0mm^2 was obtained from *Murray's law* considering an **MLA 4.0mm^2** as ischemic threshold of both LAD and LCX

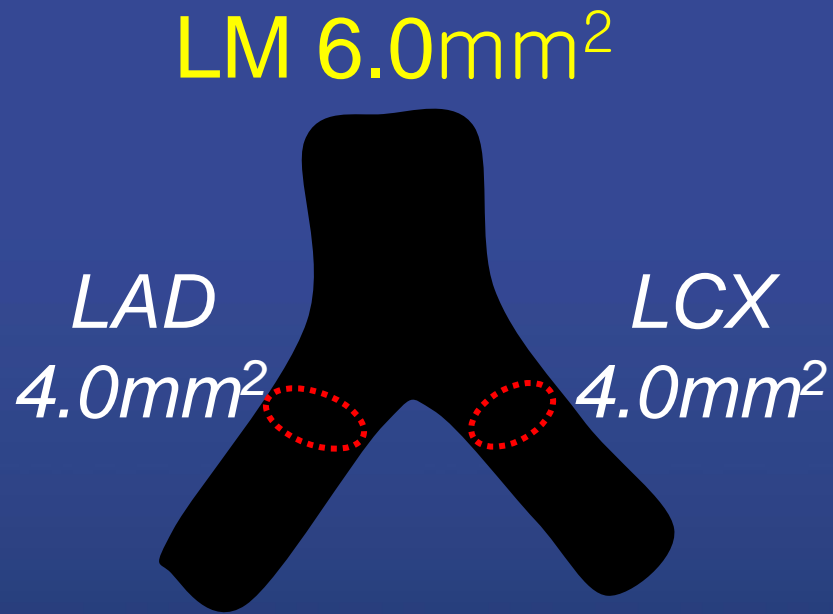

LAD	LCX	LM (Murray's)
4.0	4.0	6.35
4.0	3.9	6.27
4.0	3.8	6.19
4.0	3.7	6.11
4.0	3.6	6.04
4.0	3.5	5.96

De La Torre Hernandez et al. JACC 2011;58:351-8

Jasti et al. Circulation 2004;110:2831-6

False Assumption...

The used cut-off 4.0mm² is too Big!

LAD	LCX	LM (Murray's)
3.0	3.0	4.76
3.0	2.9	4.68
3.0	2.8	4.60
3.0	2.7	4.53
3.0	2.6	4.45
3.0	2.5	4.37

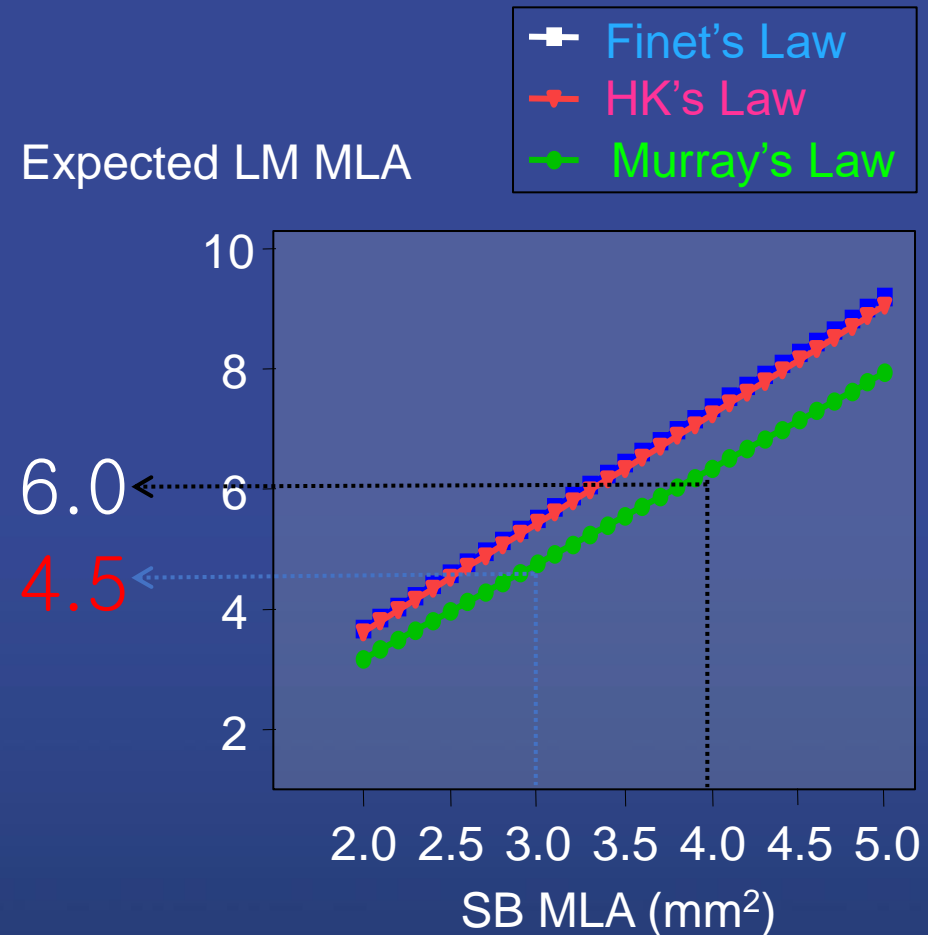

AMC Data (n=112)

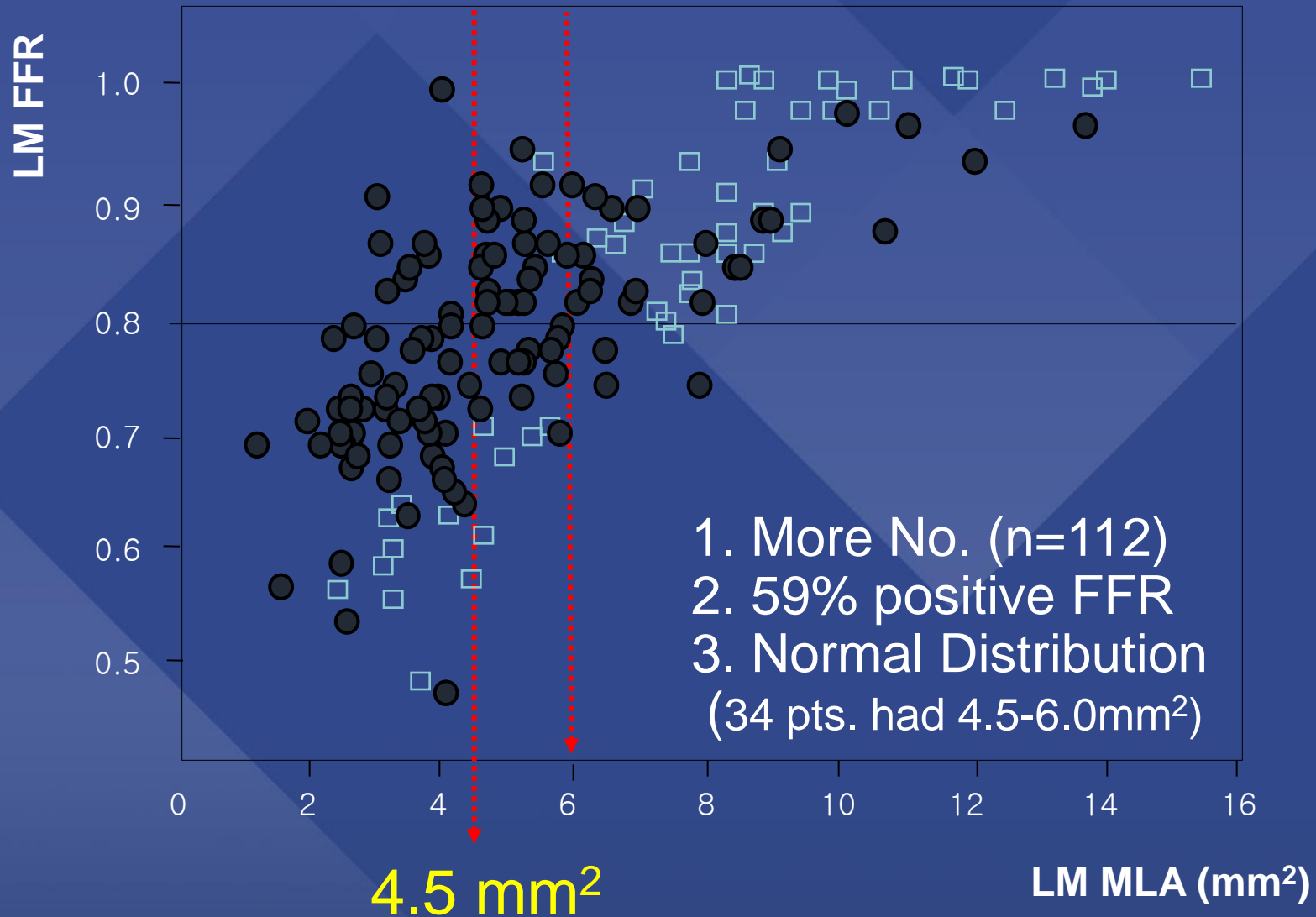

AMC Data (n=112)

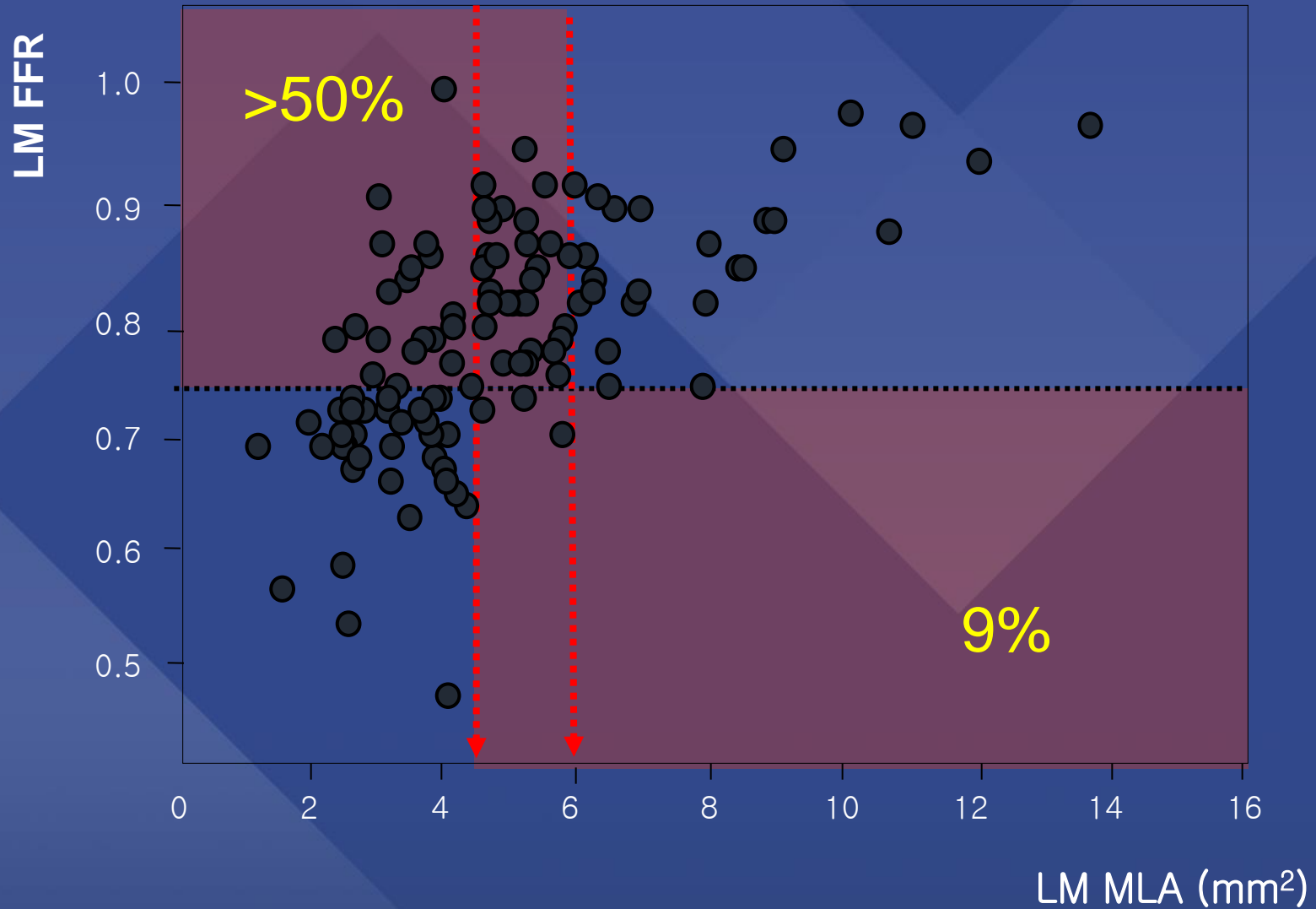

- Old data (MLA 6.0mm²) included downstream SB disease, and 32 of 55 (58%) were distal LM lesions that usually extend to the SB ostia
- Recent data (MLA 4.5mm²) evaluated only pure LM lesions, which more reliably assessed the impact of LM-MLA on functional significance

TABLE 1. Baseline Clinical, Angiographic, and IVUS Characteristics of Patients (n=55)

Age, y	62±11
Diabetes mellitus, n	20
Hypertension, n	50
Smoking, n	39
Prior bypass surgery, n	13
Ostial LM stenosis, n	20
Mid-LM stenosis, n	3
Distal LM stenosis, n	32

New LM MLA 4.5mm²

Matched with FFR <0.80
Ostial and Shaft LM Disease (N=112)

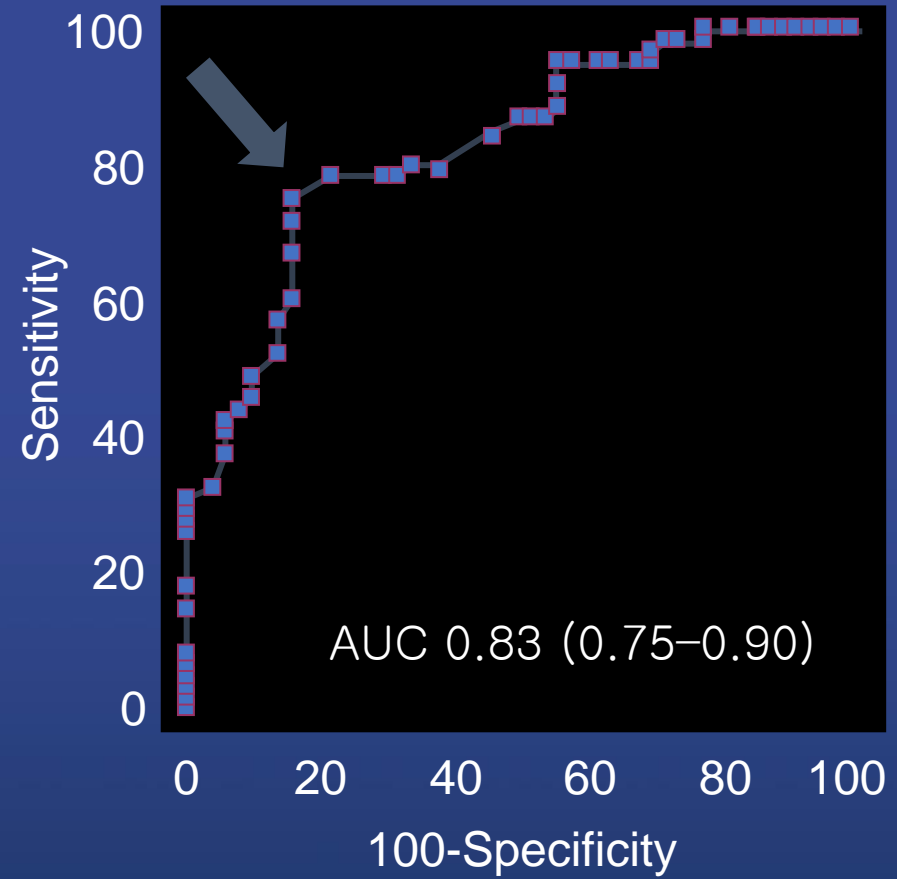

Sensitivity	79%
Specificity	80%
PPV	83%
NPV	76%

Frequency of ISR in LM Lesions

with vs. without Underexpansion

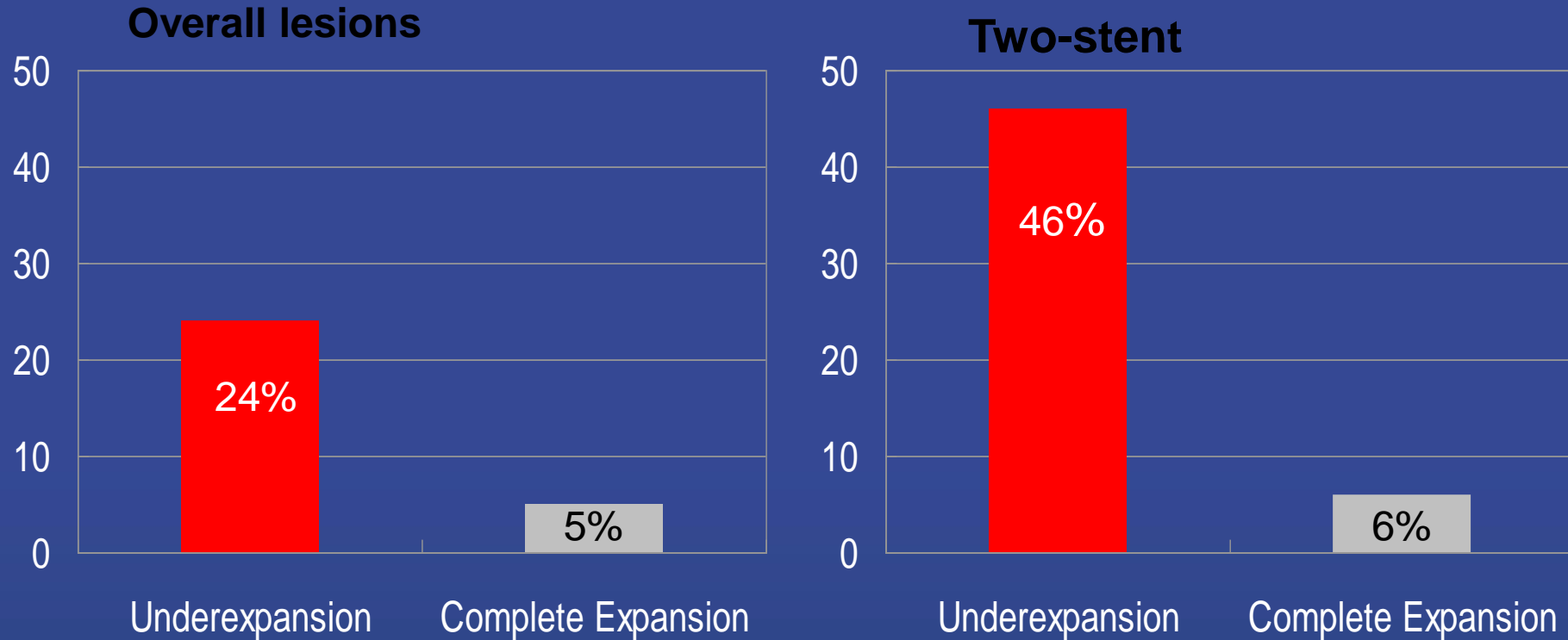

Underexpansion of at least 1 segment

Adequate expansion at all sites

OCT in LM disease

OCT-guidance associated with better outcome in LMCA stenting compared with angiography guidance alone

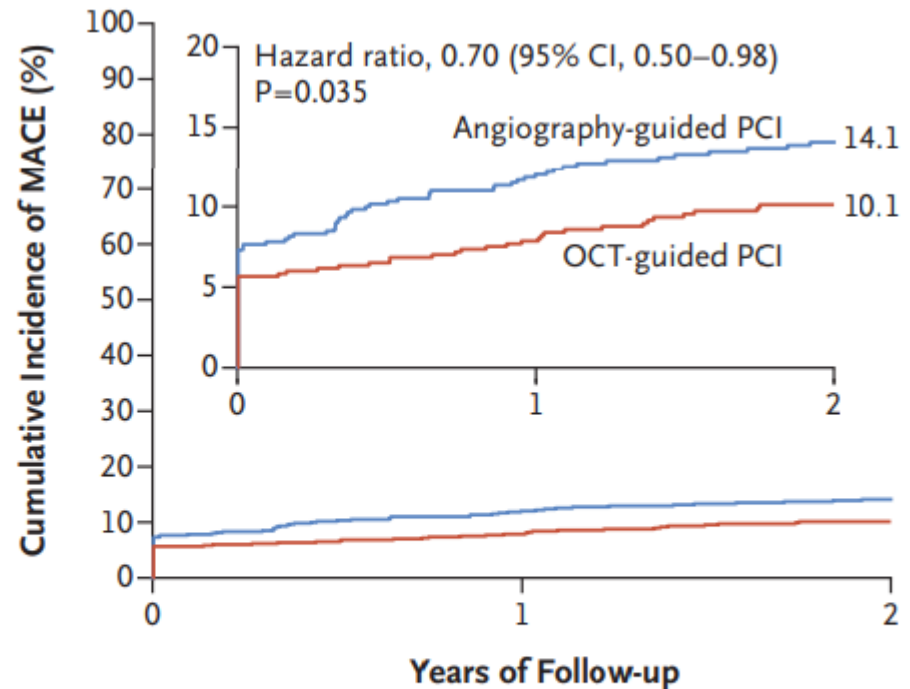

No. at Risk

Angiography-guided PCI	601	509	408
OCT-guided PCI	600	537	439

Subgroup	OCT-Guided PCI (N=600) no. of events/total no. of patients (%)	Angiography-Guided PCI (N=601) no. of events/total no. of patients (%)	Hazard Ratio (95% CI)
All patients	59/600 (10)	83/601 (14)	0.70 (0.50–0.98)
Sex			
Female	9/127 (8)	18/126 (15)	0.49 (0.22–1.08)
Male	50/473 (11)	65/475 (14)	0.76 (0.53–1.10)
Age			
<65 yr	29/249 (12)	39/248 (16)	0.73 (0.45–1.18)
≥65 yr	30/351 (9)	44/353 (13)	0.67 (0.42–1.07)
Diabetes mellitus			
Yes	10/103 (10)	16/97 (17)	0.55 (0.25–1.20)
No	48/490 (10)	66/497 (14)	0.73 (0.5–1.06)
Left main coronary artery as trial bifurcation			
Yes	15/111 (14)	20/116 (19)	0.78 (0.40–1.51)
No	44/489 (9)	63/485 (13)	0.68 (0.46–1.00)
Stent technique			
One-stent	12/209 (6)	26/219 (12)	0.47 (0.24–0.93)
Two-stent	47/388 (13)	57/382 (15)	0.80 (0.55–1.18)
Multivessel			
Yes	12/106 (12)	22/125 (18)	0.63 (0.31–1.28)
No	47/494 (10)	61/476 (13)	0.73 (0.50–1.07)
Acute coronary syndrome or staged PCI from recent AMI			
Yes	31/270 (12)	39/280 (14)	0.81 (0.51–1.30)
No	28/330 (9)	44/321 (14)	0.61 (0.38–0.98)
Calcified lesion			
None-to-minor	35/402 (9)	54/405 (14)	0.64 (0.42–0.98)
Moderate-to-severe	24/198 (13)	29/194 (15)	0.81 (0.47–1.39)
SB lesion length >5 mm by QCA			
Yes	40/425 (10)	63/413 (16)	0.60 (0.40–0.89)
No	19/159 (12)	18/169 (11)	1.13 (0.59–2.16)
SYNTAX score			
<17	17/219 (8)	22/221 (10)	0.77 (0.41–1.45)
17–21	15/189 (8)	27/181 (15)	0.52 (0.27–0.97)
>21	27/191 (14)	34/197 (18)	0.82 (0.49–1.35)

OCT-Guided PCI Better Angiography-Guided PCI Better

OCT-guidance is non-inferior in LMCA stenting compared with IVUS-guidance

Primary Endpoint

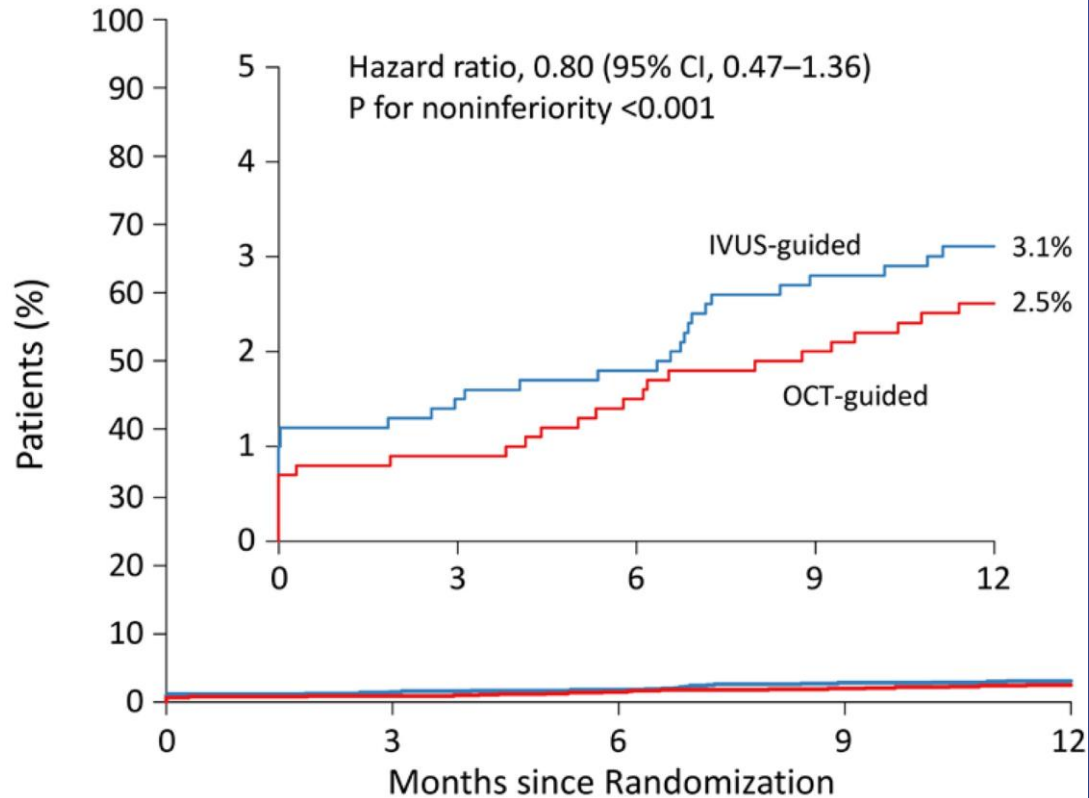

No. at Risk

	0	3	6	9	12
OCT-guided PCI	1005	990	984	979	912
IVUS-guided PCI	1003	985	981	969	893

Subgroup	Percent of Patients	Estimated 1-Yr Event Rate (%)		Hazard Ratios (95% CI)	P-for-Interaction
		OCT-guided	IVUS-guided		
Age					0.419
< 65	48.2	2.3	2.1	1.07 (0.45 to 2.51)	
≥ 65	51.8	2.8	4.0	0.68 (0.35 to 1.34)	
Sex					0.212
Female	21.6	2.3	5.1	0.46 (0.16 to 1.31)	
Male	78.4	2.6	2.6	0.99 (0.53 to 1.85)	
Diabetes mellitus					0.222
Yes	33.4	4.4	3.8	1.14 (0.54 to 2.43)	
No	66.6	1.6	2.8	0.59 (0.28 to 1.25)	
Acute coronary syndrome					0.710
Yes	23.4	3.0	4.3	0.69 (0.26 to 1.81)	
No	76.6	2.4	2.7	0.86 (0.46 to 1.61)	
Left ventricular ejection fraction					0.847
≤ 50%	11.2	6.3	8.1	0.78 (0.26 to 2.38)	
> 50%	88.8	2.0	2.9	0.69 (0.35 to 1.34)	
Left main disease					0.868
Yes	13.2	5.3	6.8	0.78 (0.28 to 2.16)	
No	86.9	2.2	2.5	0.87 (0.47 to 1.61)	
Bifurcation disease					0.901
Yes	52.6	3.1	3.7	0.83 (0.43 to 1.61)	
No	47.4	1.9	2.4	0.78 (0.32 to 1.87)	
Diffuse long coronary artery lesion					0.077
Yes	58.2	3.3	2.9	1.15 (0.60 to 2.22)	
No	41.8	1.4	3.4	0.41 (0.16 to 1.05)	
Severely calcified lesion					0.149
Yes	7.6	7.9	8.1	1.36 (0.60 to 3.07)	
No	92.4	2.1	2.7	0.61 (0.31 to 1.23)	
Multivessel disease					0.547
Yes	61.6	3.2	4.2	0.75 (0.42 to 1.36)	
No	38.4	1.5	1.4	1.13 (0.35 to 3.71)	
SYNTAX score					0.096
Low	79.0	1.5	2.9	0.52 (0.26 to 1.04)	
Intermediate	15.6	5.7	3.5	1.63 (0.57 to 4.70)	
High	5.4	9.9	5.3	1.93 (0.46 to 8.06)	

0.1 1 10
OCT-guided PCI better IVUS-guided PCI better

FFR in LM disease

FFR guided and angio guided provisional stenting of LM DKCRUSH-VI trial

- primary endpoint : 1 yr composite of MACE

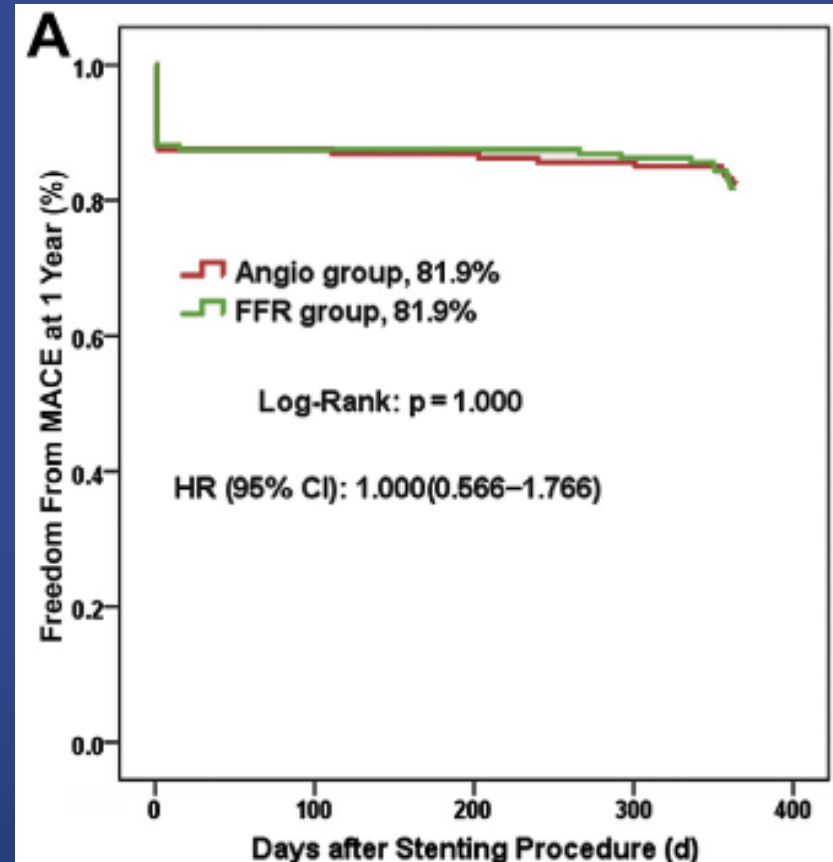

Angiographic and FFR guidance of provisional SB stenting of LM bifurcation lesions provided similar 1-year clinical outcome.

FFR guided PCI in Equivocal LMCA

- In 213 patients with an equivocal LMCA stenosis
- FFR ≥ 0.80 : Medication (n=138) vs. FFR < 0.80 : CABG (n=75)

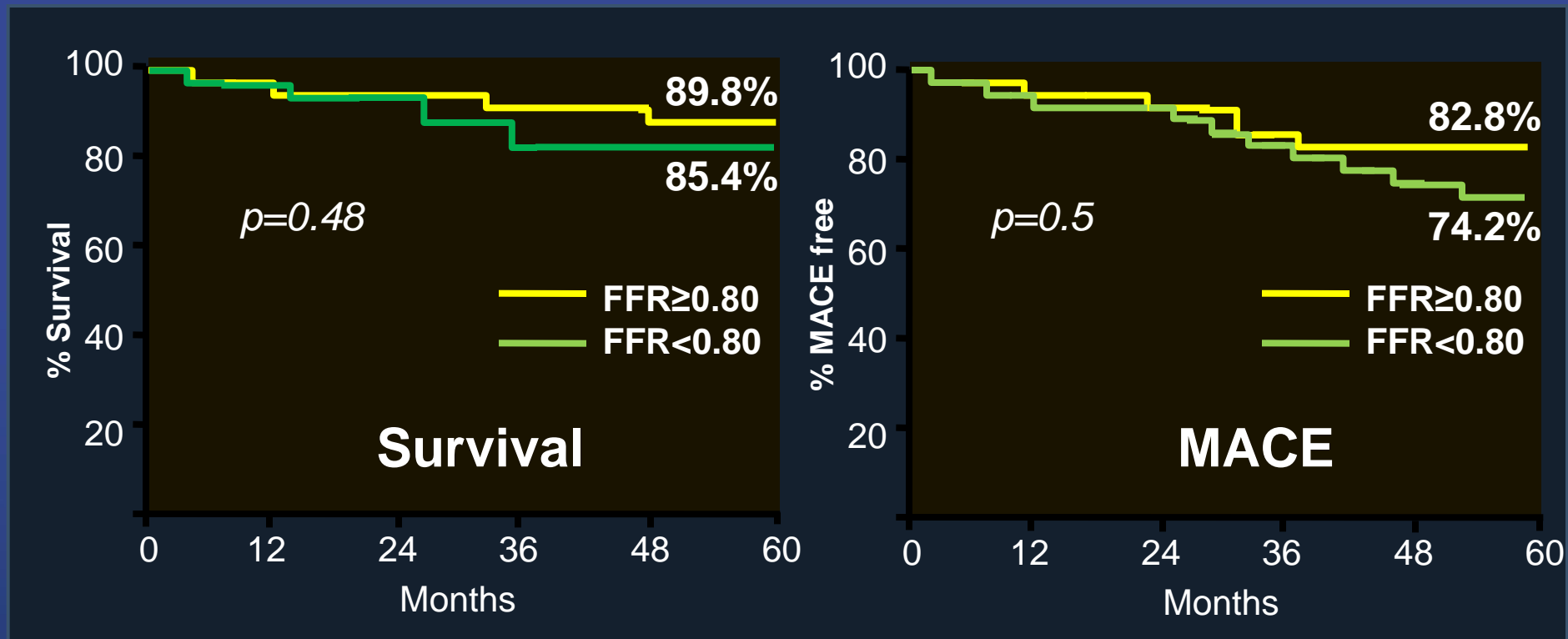

An FFR-guided strategy showed the favorable outcome.

Use of IVUS vs. FFR in SB Assessment After LM Cross-over

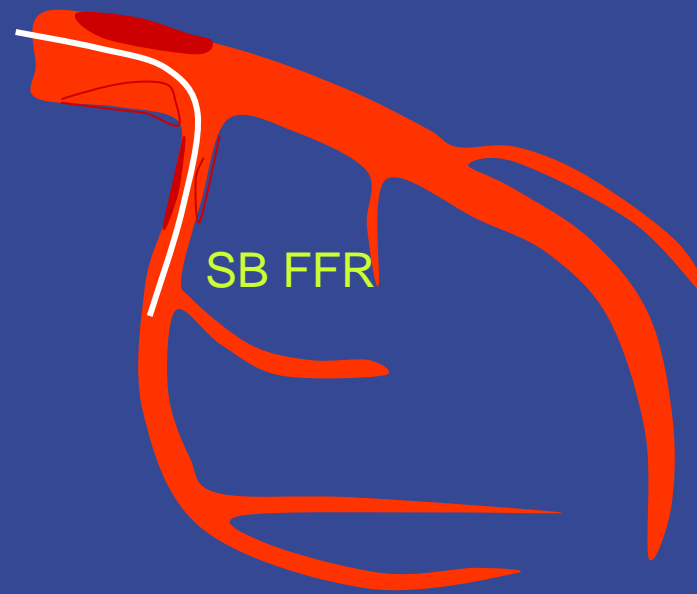

	SB-pullback IVUS	SB FFR
Advantage	<ul style="list-style-type: none">Confirm the anatomical compromise and MLA lossMechanism of SB jailing	<ul style="list-style-type: none">Confirm the functional SB compromise
Pitfalls	<ul style="list-style-type: none">MLA-FFR mismatchNo MLA criteriaLow feasibility	<ul style="list-style-type: none">Minority - not feasible

Functional Compromise of LCX after LM Cross-Over Stenting

Preprocedural MLA and plaque burden
of poststenting LCX FFR < 0.80

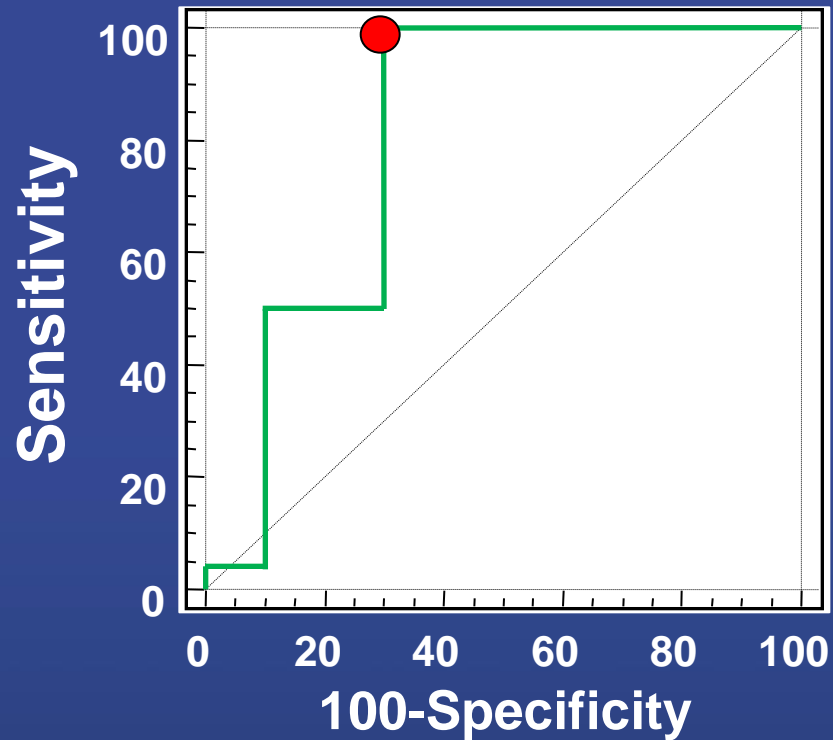

MLA 3.7 mm²

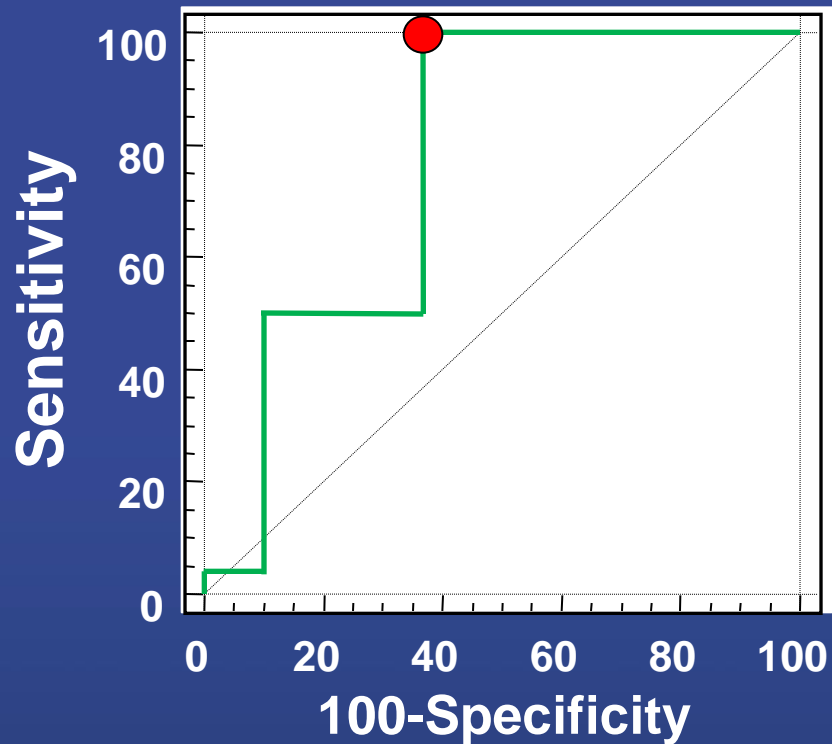

Plaque burden 56%

Functional LCX Compromise

In LMCA Bifurcations (LCX ostial DS<50%)

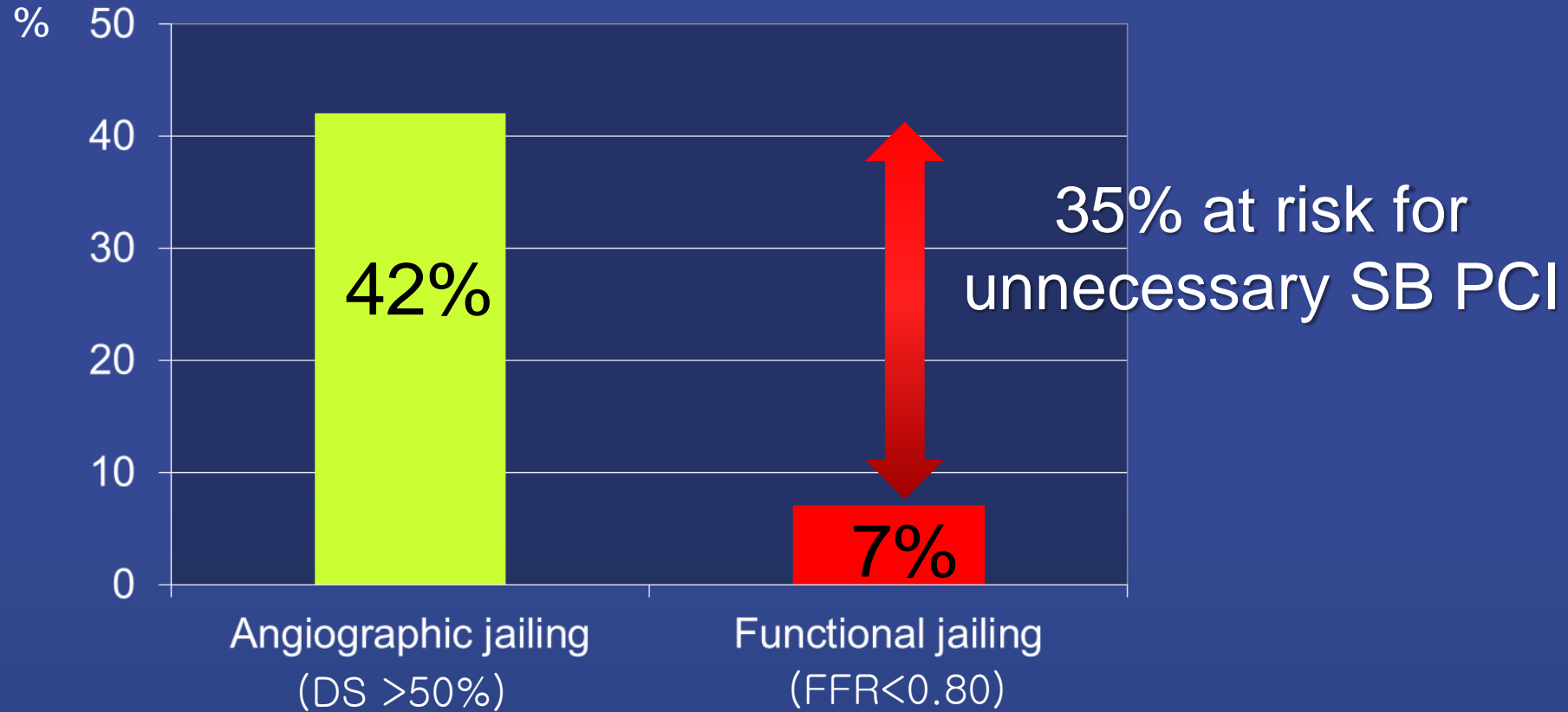

When Pre-PCI LCX Ostial DS < 50%,
Just Do Single Stent!

LMCA Bifurcation

Post-stenting LCX Stenosis

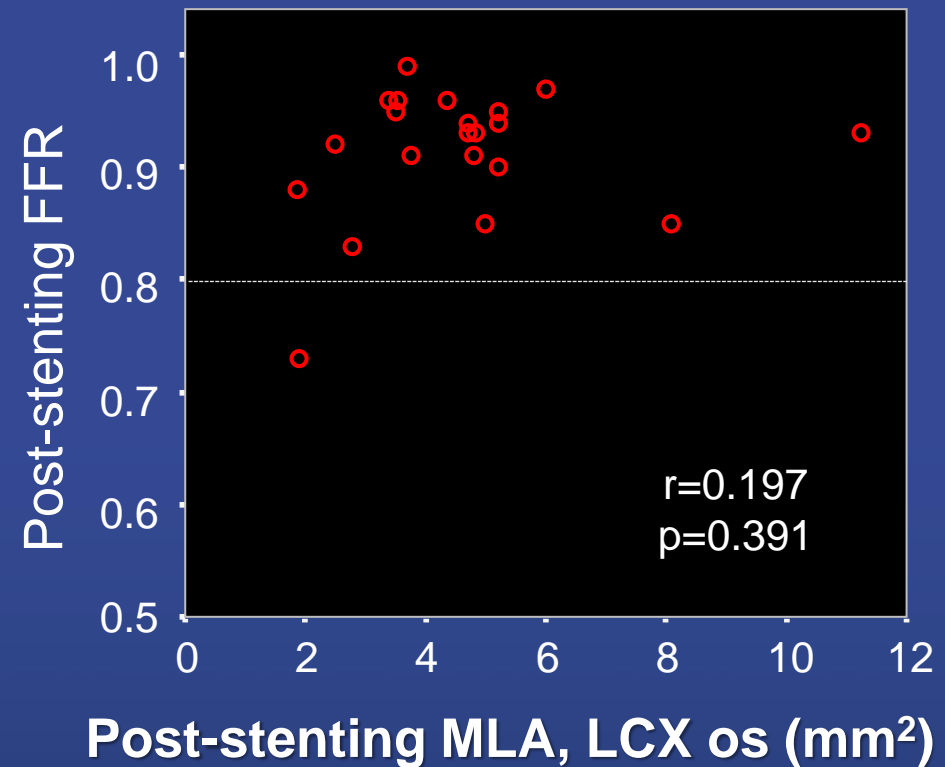
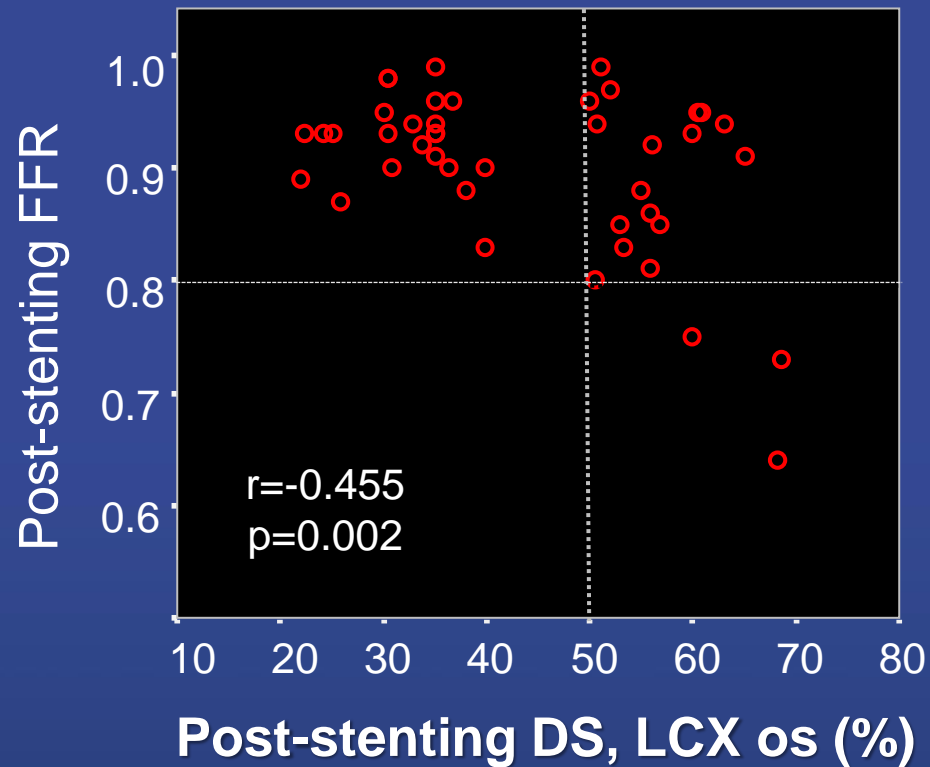

Why Mismatch?

- Lesion eccentricity of SB
- Negative remodeling of ostium
- Various size of myocardium
- Strut artifacts
- Focal carina shift

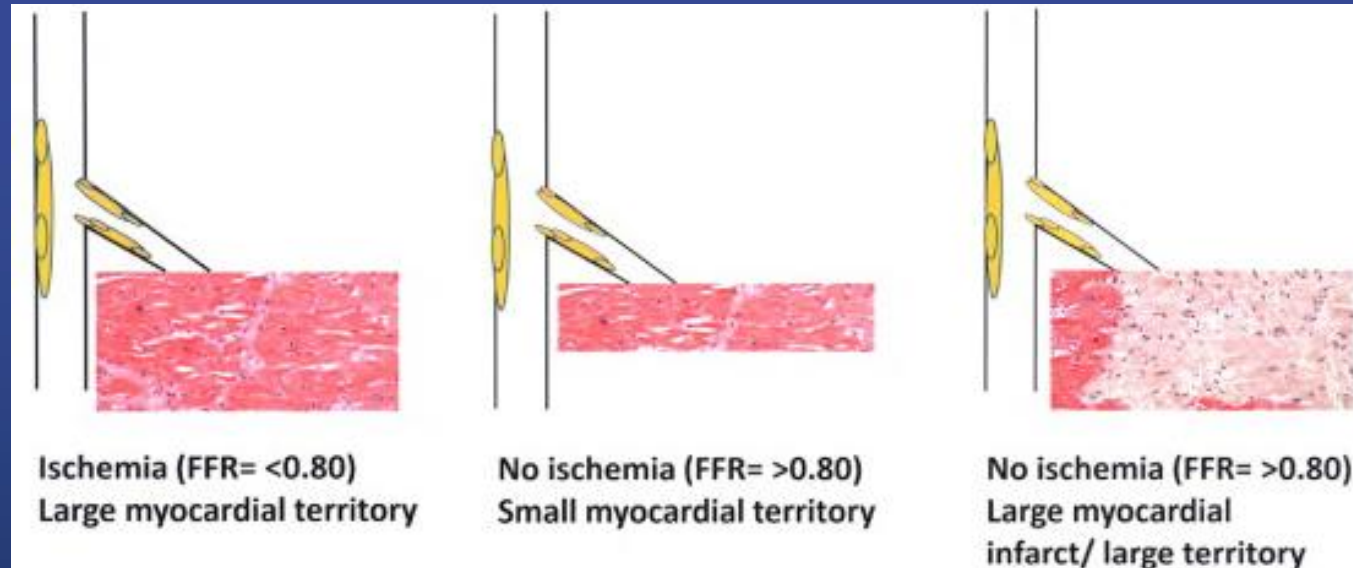

PCI vs. CABG for Left Main Disease

Extended Follow-Up of the **BEST** trial : Primary Composite Endpoint

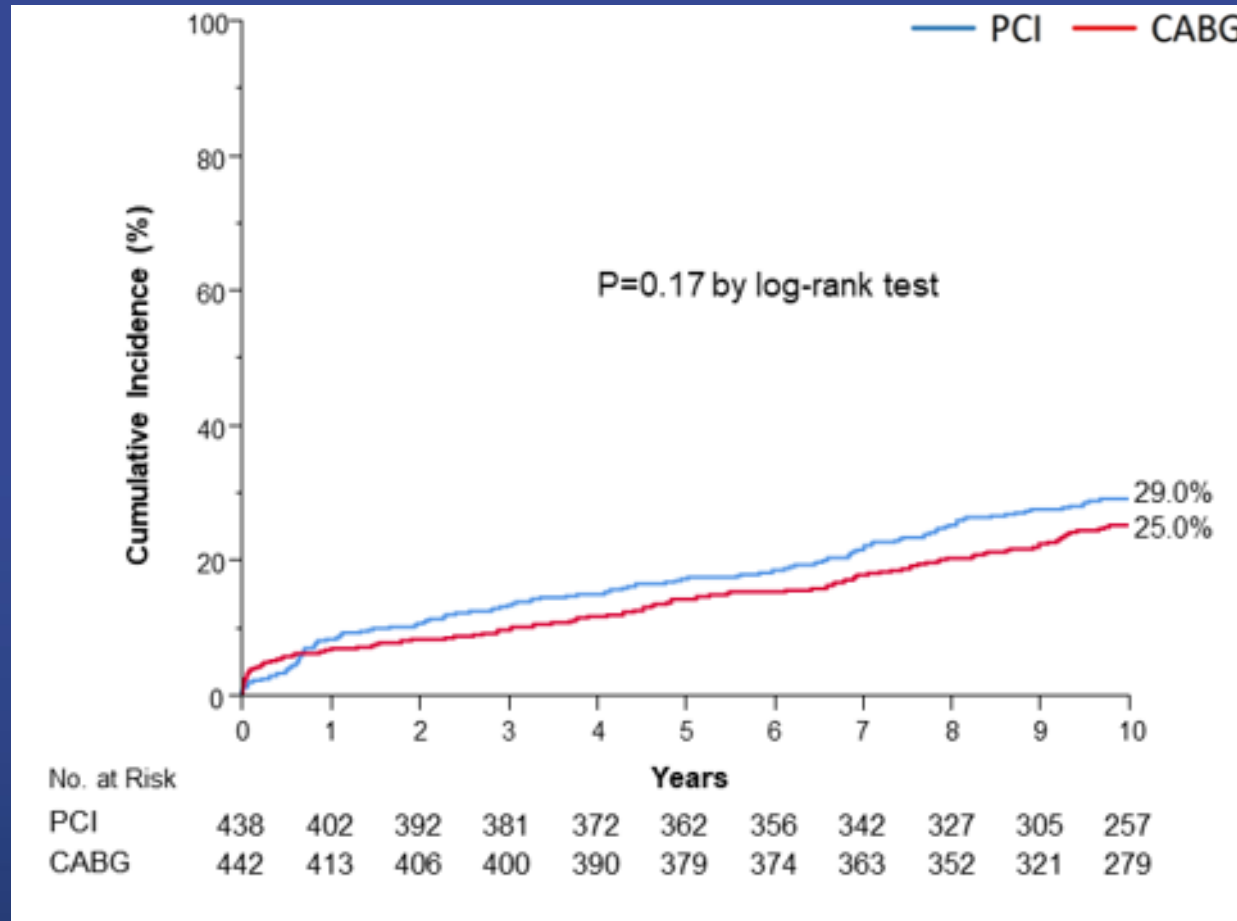

PCI vs. CABG for Left Main Disease

Extended Follow-Up of the **BEST** trial : Death, Stroke, or MI

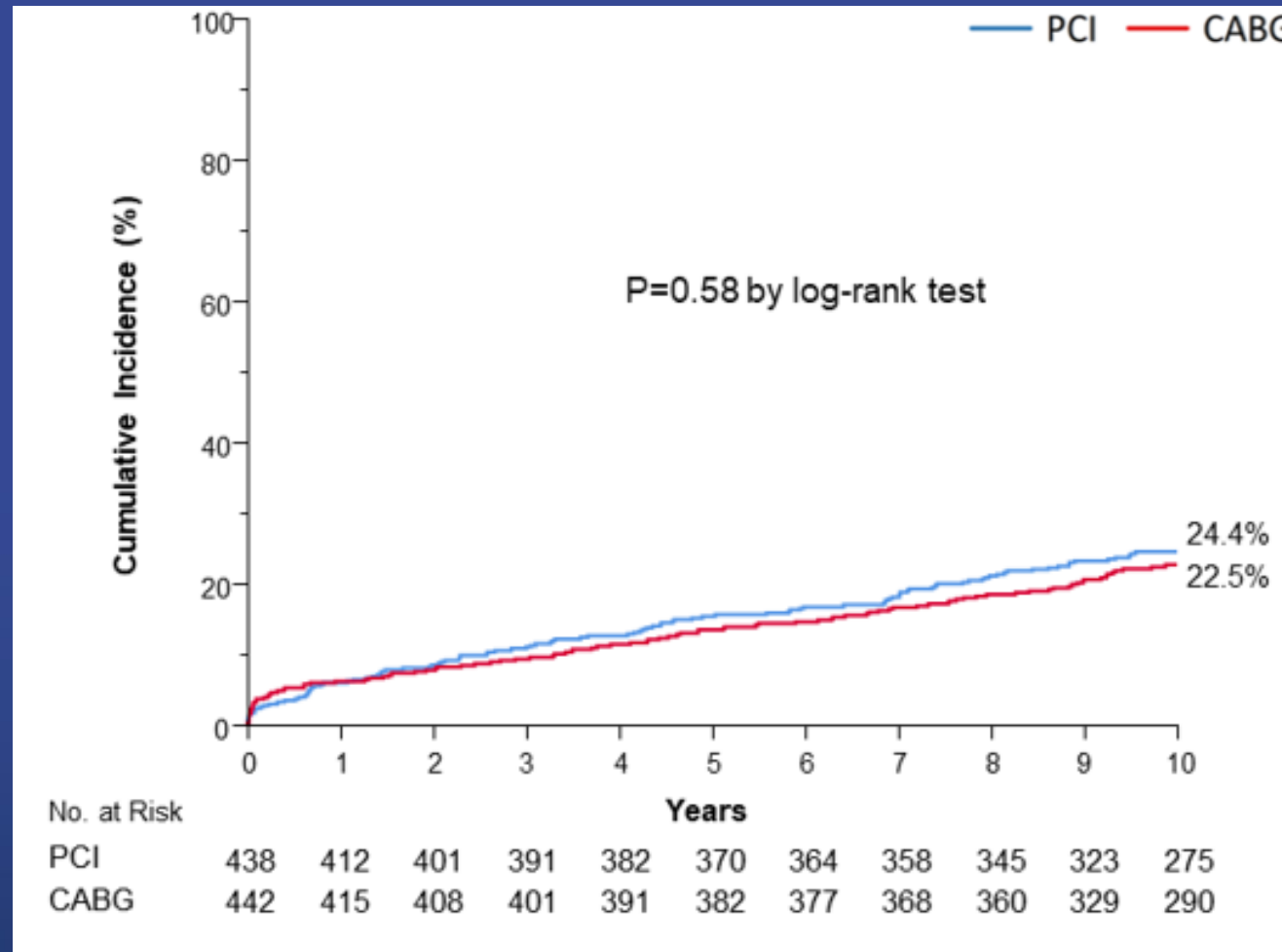

PCI vs. CABG for Left Main Disease

Extended Follow-Up of the **BEST** trial : All-cause death

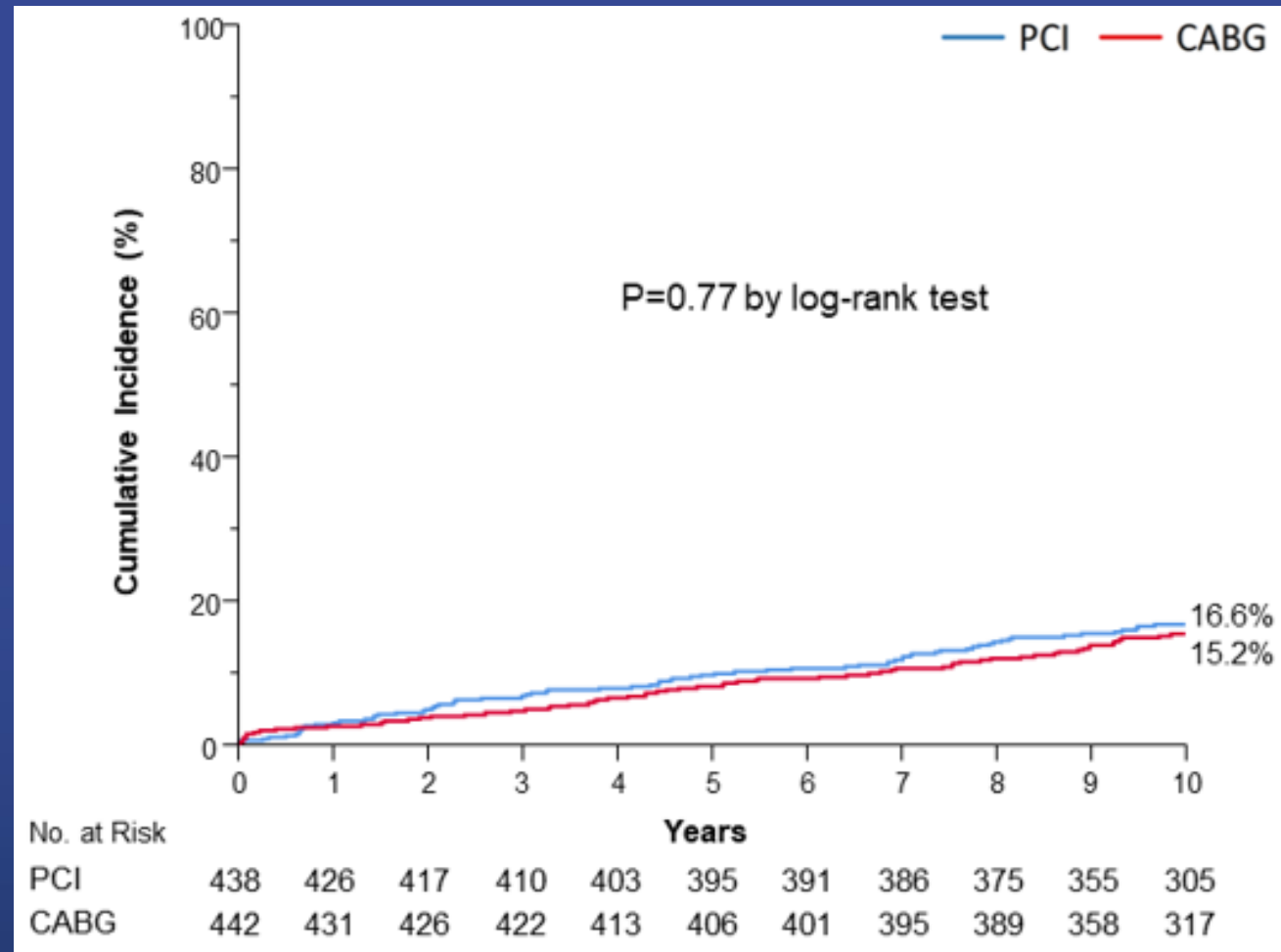

PCI vs. CABG for Left Main Disease

Extended Follow-Up of the **BEST** trial : Repeat Revascularization

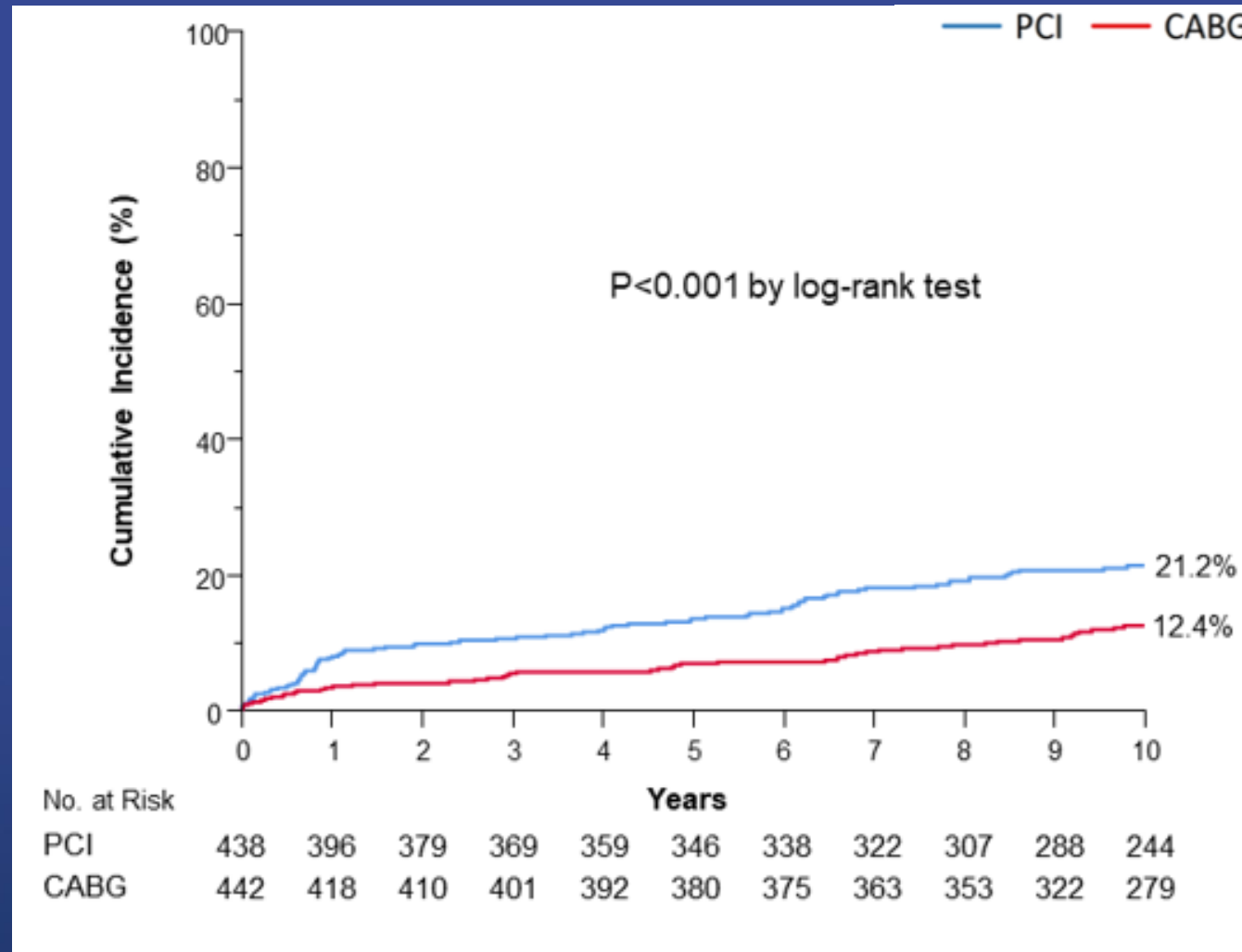

JM Ahn et al. Circulation 2022 sep 19

PCI vs. CABG for Left Main Disease

Extended Follow-Up of the **BEST** trial : Repeat Revascularization

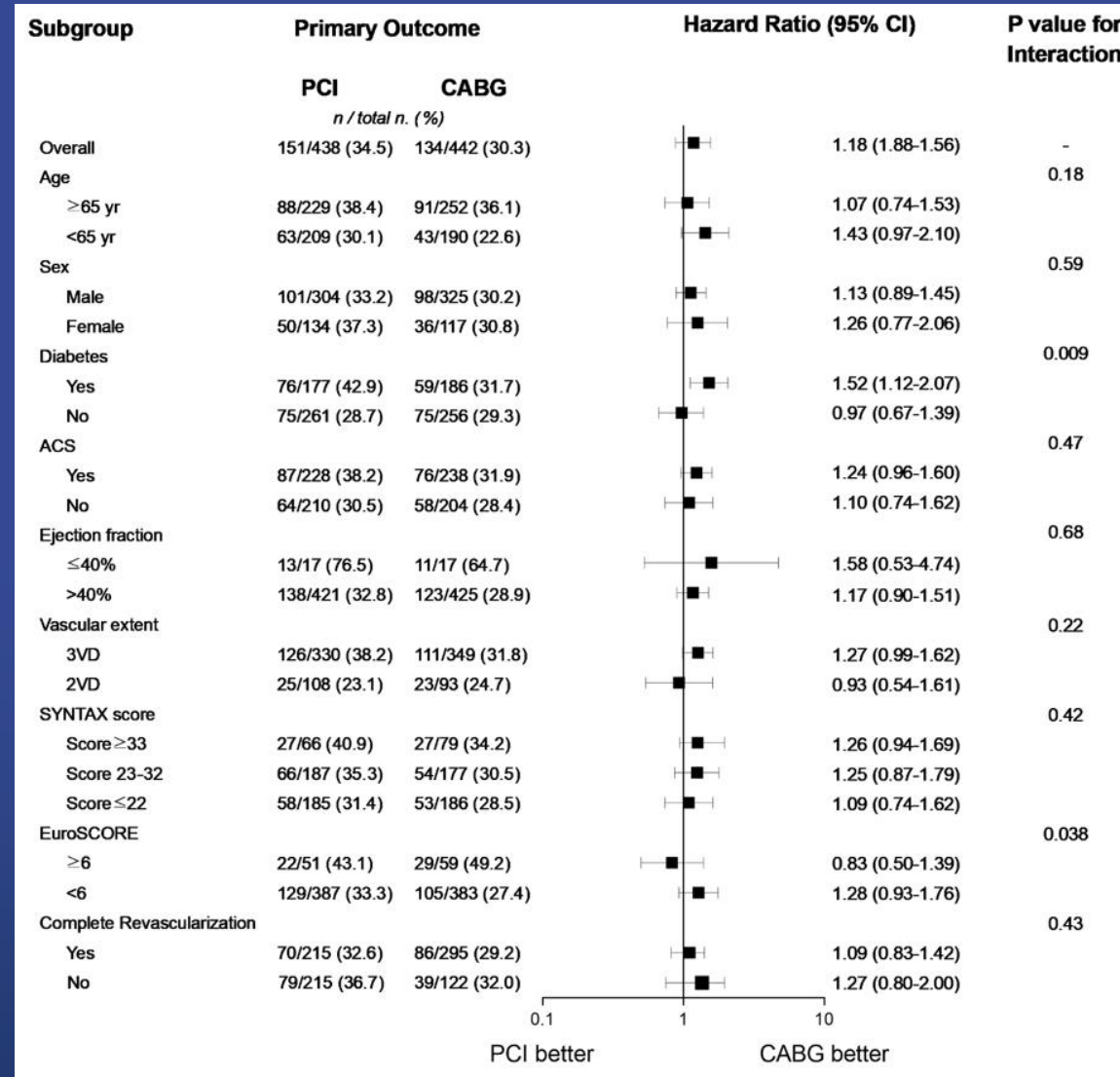

JM Ahn et al. Circulation 2022 sep 19

ISR

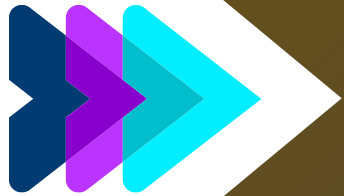

WOLVERINE™

Cutting Balloon™ Dilatation Device

In-Service Presentation

Indications and Intended Use

The WOLVERINE™ Cutting Balloon Device is indicated for use in patients with coronary vessel disease who are acceptable candidates for coronary artery bypass graft surgery, should it be urgently needed, for the purpose of improving myocardial perfusion.

In addition, the target lesion should possess the following characteristics:

- Discrete (< 15 mm in length), or tubular (10 mm to 20 mm in length)
- Reference vessel diameter (RVD) of 2.00 mm to 4.00 mm
- Readily accessible to the device
- Light to moderate tortuosity of proximal vessel segment
- Nonangulated lesion segment (< 45°)
- Smooth angiographic contour
- Absence of angiographically visible thrombus

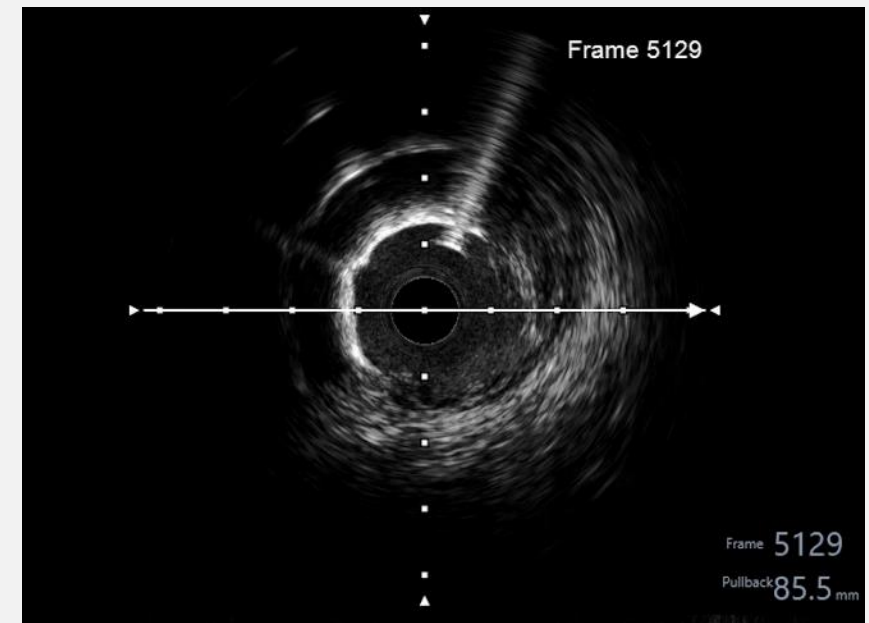

WOLVERINE™ FDA US IFU Updates

November 2021

Boston
Scientific

INTENDED USE/INDICATIONS FOR USE

The Wolverine Cutting Balloon Device is indicated for dilatation of stenoses in coronary arteries for the purpose of improving myocardial perfusion in those circumstances where a high pressure balloon resistant lesion is encountered. In addition, the target lesion should possess the following characteristics:

- Discrete (< 15 mm in length), or tubular (10 mm to 20 mm in length)
- Reference vessel diameter (RVD) of 2.00 mm to 4.00 mm
- Readily accessible to the device
- Light to moderate tortuosity of proximal vessel segment
- Nonangulated lesion segment (< 45°)
- Smooth angiographic contour
- Absence of angiographically visible thrombus and/or calcification

Changes

- Removed “and/or calcification” in target lesion characteristics bullet points
- Emergency surgical backup now a clinical consideration
- Additional cleanup and formatting for clarity

Rationale

- Align Instruction for Use with modern product usage
 - Cutting Balloon was first introduced before stents were approved for coronary use
 - Modern use of cutting balloon has since changed
- Supported by extensive literature, clinical data and real-world experience
- FDA approved changes in Nov 2021

Product Design

Traditional balloon angioplasty can result in complications like:

VESSEL
DISSECTION

POOR
LUMINAL GAIN

LESION
RECOIL

BALLOON
SLIPPAGE

POOR STENT
APPOSITION

The WOLVERINE™ Advantage

The unique design of the WOLVERINE Cutting Balloon is designed with **proprietary atherotomes** on a **low pressure non-compliant balloon** to directly address each of these complications

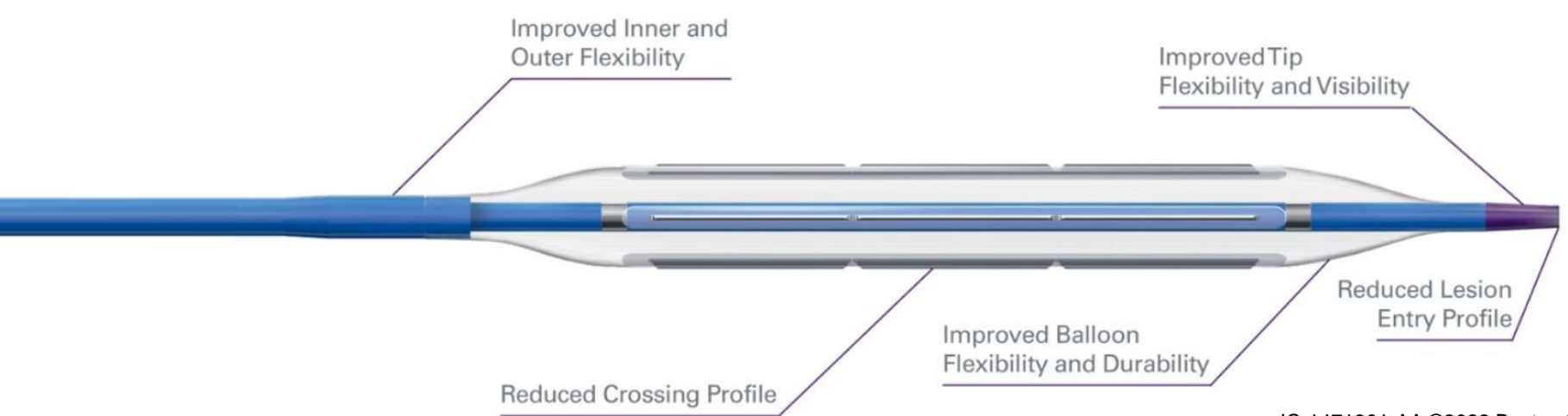

Balloon Matrix and Inflation Pressures

Monorail Balloon Catheter with working lengths of 6, 10 and 15 mm

For vessels with reference diameter of 2.0 – 4.0 mm

		BALLOON BODY LENGTH		
		6 mm	10 mm	15 mm
BALLOON DIAMETER (mm)	2.00	3 Atherotomes		
	2.25			
	2.50		5F Compatible GUIDEZILLA II 6F	
	2.75			
	3.00			
	3.25			
BALLOON DIAMETER (mm)	3.50	4 Atherotomes	6F Compatible GUIDEZILLA II 7F	
	3.75			
	4.00			

INFLATION PRESSURE RATING

Nominal = 6 ATM

Rated Burst = 12 ATM

Sizing Considerations



WOLVERINE™ utilizes the NC EMERGE™ Catheter Platform, yet the balloon was designed to have a lower nominal pressure resulting in a different compliance

Growth Chart Example (3.0 mm)

Wolverine™ Coronary Cutting Balloon™
MONORAIL™
 Microsurgical Dilatation Device

atm - kPa Pressure		3.00mm Balloon O.D.
3.0 - 304		2.88
4.0 - 405		2.94
5.0 - 507		2.99
6.0 - 608	NOMINAL	3.06
7.0 - 709		3.10
8.0 - 811		3.15
9.0 - 912		3.18
10.0 - 1013		3.22
11.0 - 1115		3.25
12.0 - 1216	RATED*	3.28

***Rated Burst Pressure. DO NOT EXCEED.**

Sizing Considerations:

WOLVERINE grows roughly a quarter size when going from nominal (6 ATM) to rated burst pressure (12 ATM)

Physician consensus is to measure the normal distal reference with IVUS and then downsize WOLVERINE a half size from that measurement

Oversizing at nominal pressure will cause atherotomes to be “pillowed” by the balloon and may not provide adequate forces to modify calcium

Oversizing at rated burst pressure may lead to vessel stretching and trauma due to balloon growth (not atherotomes)

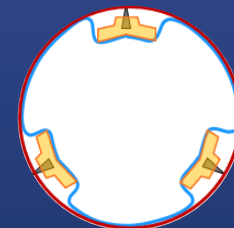
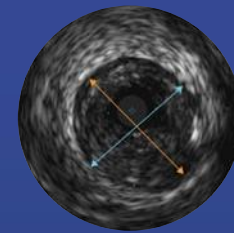

Oversizing Example
 Blue = Balloon
 Red = Vessel



Device Preparation and Use Instructions

Device Preparation

Important: WOLVERINE™ preparation uses a wet negative prep procedure. Customary balloon preparation methods do not apply!

1

Sizing

- The Wolverine IFU states that the inflated diameter of the device should approximate a ratio of 1.1:1 in relation to the average diameter of the reference vessel. Oversizing increases risk of perforation. **As stated earlier, sizing a quarter to half size down may be needed if using higher inflation pressures.**

2

Unpacking

- Using sterile technique, remove the device in its protective hoop from its package and place onto a sterile field.
 - Do not remove the device from its protective hoop.
 - Do not remove the balloon protector from the device tip.

3

Attach Stopcock & Prepare Inflation Device

- Connect a three-way stopcock to the balloon port.
 - Turn stopcock lever OFF to the balloon.
 - Prepare an inflation device with 5 cc of contrast solution (mixture must be at least 50:50 contrast medium and sterile saline).



Device Preparation

4

Attach Inflation Device & Purge

- Attach the inflation device to stopcock.
 - Assure luer connections are properly aligned to avoid stripping the luer thread causing subsequent leakage and use care when connecting the device to avoid damage (e.g., shaft kink).
 - Purge stopcock by flushing 1-2 cc of contrast medium through the middle port.



5

Pull Full Negative

- Turn the stopcock lever towards the middle port or open to the balloon and immediately withdraw inflation device plunger to full negative and place the inflation device in a locked position. This will maintain a constant vacuum on the device.



6

Remove Device from Hoop

- When the device is ready to be inserted into the body, remove the device from its protective hoop. Use care when removing the device to avoid damage (e.g., shaft kink).



Device Preparation

7

Remove Balloon Protector

- Using straight force (not a twisting motion), pull the balloon protector distally from the device tip. For WOLVERINE MR Cutting Balloon Devices, remove the mandrel distally after removing the balloon protector.
 - Caution: If unusual resistance is felt during removal of the balloon protector or mandrel, do not use the device and replace with another.

8

Coiling & Securing with CLIPIT Clip

- The WOLVERINE MR Cutting Balloon Device may be coiled once and secured using the CLIPIT Clip provided in the device package.
 - Only the proximal shaft should be inserted into the CLIPIT Clip; the clip is not intended for the distal end of the device.
 - Remove the CLIPIT Clip prior to inserting the device into the patient's body.

9

Flush Guidewire Lumen

- Flush the guidewire lumen of the device with heparinized saline. For WOLVERINE MR Cutting Balloon Device flush through the distal tip of the device.

10

Sterility

- Maintain device on a sterile table until ready to use.



Inflation & Removal Instructions

Inflation

- 1 Go Slow**
 - Under fluoroscopy, slowly inflate the device (1 ATM/5 sec) to 6 ATM (nominal size).
 - Do not inflate the device above 12 ATM (rated burst pressure).
 - If difficulty is experienced during balloon inflation, do not continue inflation; deflate and remove the device.
- 2 Treat Distal then Proximal**
 - When using the device on long lesion segments, treat distal portion first and then proximal lesion segment second. Repeat coronary arteriography after each use to evaluate results.

Tips and Tricks

Prior to advancing the catheter, it may help to increase pressure to 1 atm and then pull negative to aid in loosening the packaged balloon crimp and provide added flexibility

Removal

- 1 Deflate & Pull Negative**
 - Deflate the device by dialing down on the inflation/deflation device, then pull a negative vacuum. Maintain vacuum on the device and verify full deflation under fluoroscopy.
- 2 Confirm Successful Result**
 - Repeat coronary arteriography to confirm successful result.
- 3 Withdraw**
 - Withdraw the device into the guiding catheter. While withdrawing the deflated device and guidewire from the guide catheter through the hemostasis valve, tighten the hemostasis valve.

Tips and Tricks

Deflating slowly by dialing down pressure methodically to optimize balloon re-wrap



WOLVERINE[™]
Cutting Balloon[™] Dilatation Device

Clinical Use Scenarios

WOLVERINE™

The right tool for vessel preparation device

Proper Solution to Help Prepare Lesions Prior to Stenting

WOLVERINE is right tool at helping treat a wide range of lesions:

- Cuts fibrotic plaque to limit recoil
- Cracks thin concentric and eccentric calcium
- Prepare small vessels prior to Drug Coated Balloon
- Address In-Stent Restenosis
- Limit balloon slippage in coronary ostium and bifurcation lesions

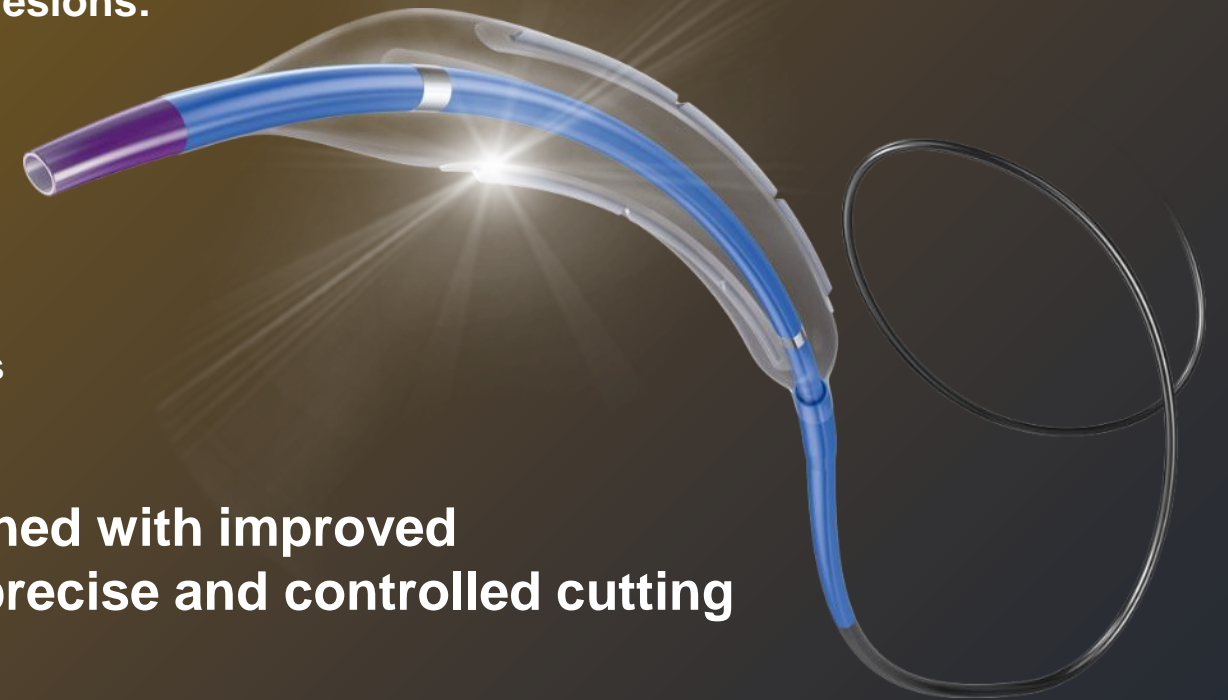

➤ **Cutting balloon angioplasty device designed with improved crossability and deliverability, to deliver precise and controlled cutting action**

Clinical Use Scenarios

	Small Vessel Lesions REDUCE RESTENOSIS	Ostial and Bifurcation Lesions PLAQUE SHIFT	Fibrotic Lesions CHANGE LESION COMPLIANCE	Calcified Lesions CRACK CALCIUM TO ALLOW EXPANSION
LESION CHALLENGES	<ul style="list-style-type: none"> • High rates of restenosis • Tendency to dissect • Abrupt closure¹ 	<ul style="list-style-type: none"> • Recoil • Plaque Shift • Side Branch Compromise 	<ul style="list-style-type: none"> • High concentration of elastin and muscle fibers • High risk of vessel recoil 	<ul style="list-style-type: none"> • Calcium deposits in plaque that prevent lumen gain • Varying degrees of burden and arcs
CUTTING BALLOON OBJECTIVES	<ul style="list-style-type: none"> • Use as stand-alone therapy • DCB or Stent? 	<ul style="list-style-type: none"> • Dilates while reducing elastic recoil² • More plaque compression • Minimal plaque shift • Less vessel stretching³ 	<ul style="list-style-type: none"> • Atherotomes score through fibrotic plaque⁴ • Reduce hoop strain and limit recoil • Lumen Gain 	<ul style="list-style-type: none"> • Use as stand-alone therapy in eccentric and thin concentric calcium • Possible additive therapy with atherectomy • Lumen Gain

WOLVERINE™ Mechanism of Action

Porcine Artery Models

ACUTE

14-DAY

CUTTING
BALLOON

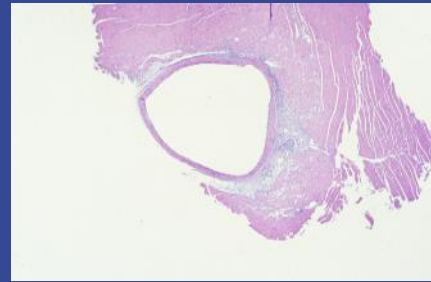
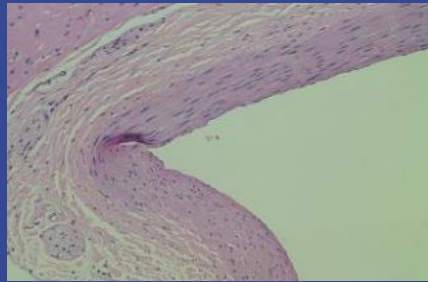

POBA

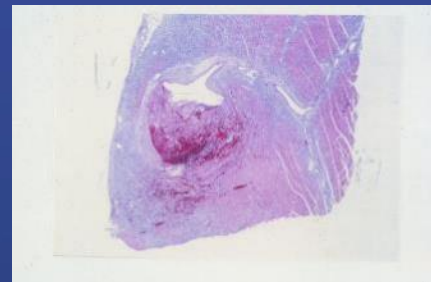
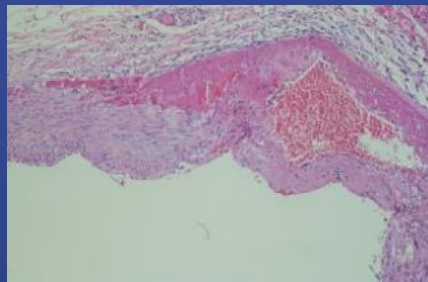

Acutely there is **over stretch*** and visible trauma to the vessel wall with POBA

At 14-days the vessel has **recoiled with POBA** and stayed open with cutting balloon

*This level of over-stretch was done for investigational purposes only

Reliable Option

- **25+ Year Track Record:** WOLVERINE has been used for over 25 years, and has a long track record of safety with real-world patients and clinical trials
- **Atherotome Height:** Approximately the same height as 1st generation stents or a human hair
- **Penetration Depth:** Even when placed in healthy tissue, WOLVERINE's atherotomes typically only penetrate partially into the media

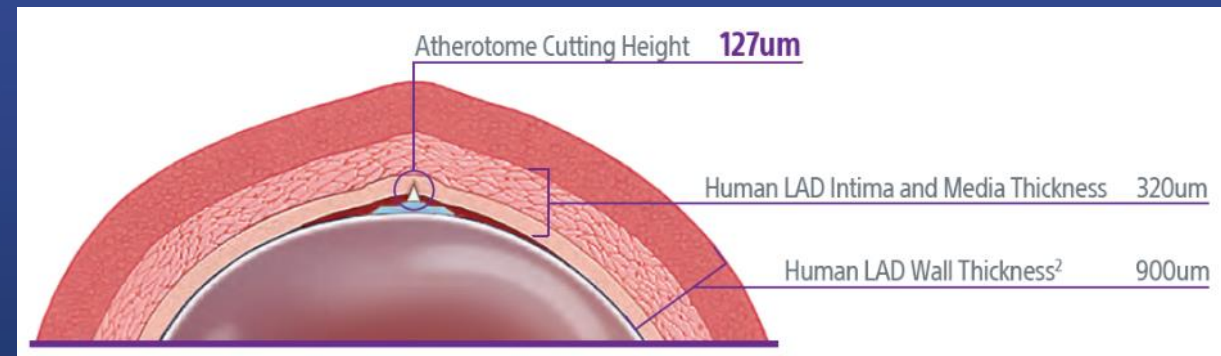



WOLVERINE[™]
Cutting Balloon[™] Dilatation Device

Calcium Modification

Calcium Needs to be Properly Treated

Calcium is a growing problem that can negatively impact PCIs if left untreated

Calcium is prevalent in patients undergoing PCI

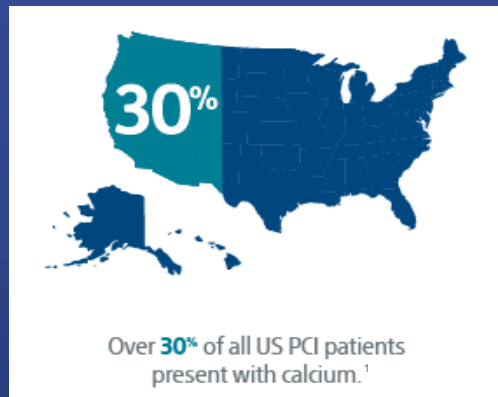

Calcium leads to worse clinical outcomes

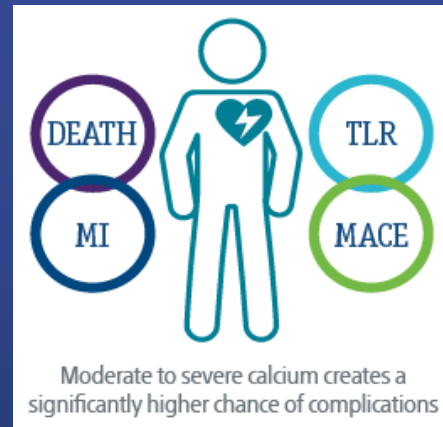

Calcium can inhibit optimal stenting

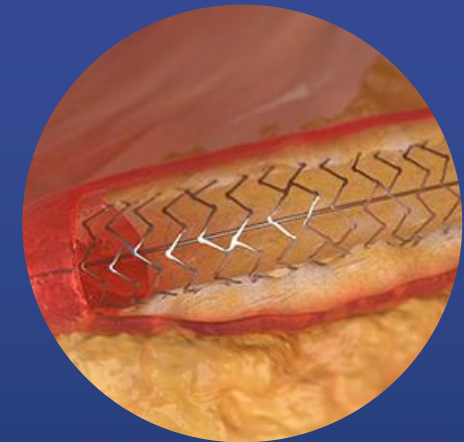

Calcium Morphology

CONCENTRIC



360° Calcium Arc
Smooth Surface

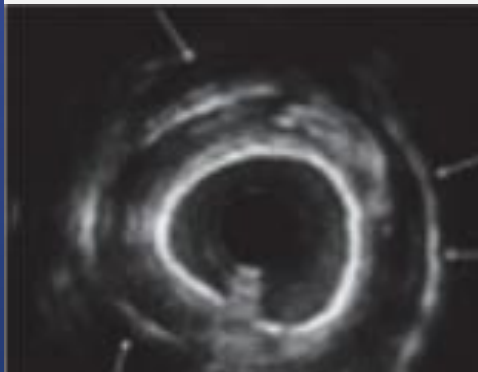

ECCENTRIC



180 – 270° Calcium Arc
Irregular Surface



NODULE



90 – 180° Calcium Arc
Luminal protrusion and
irregular leading edge

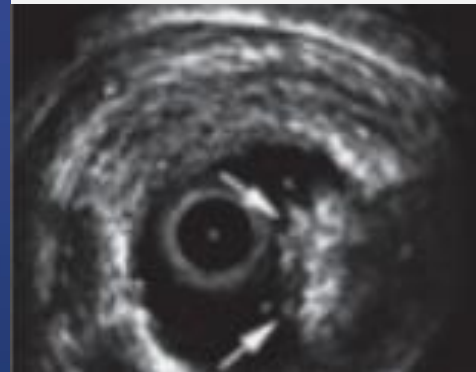

PSEUDO-NODULE

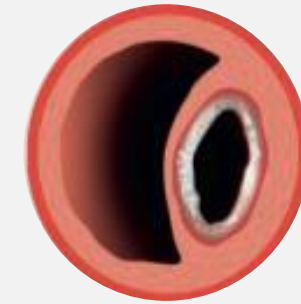

Extra-plaque
during CTO-PCI



The Right Tools Make a Difference



➤ **Controlled Mechanism of Action**

Atherotomes anchor to calcium and produce controlled, longitudinal fractures

➤ **Strategic Atherotome Placement**

Enables up to 4 points of contact with calcium, improving the probability of modification with a single balloon

➤ **Focused Force to Amplify Impact**

Pressure at atherotomes amplified to precisely fracture calcium at lower balloon inflation pressures

WOLVERINE™
Cutting Balloon™ Dilatation Device

Calcific Lesion Modification Strategy

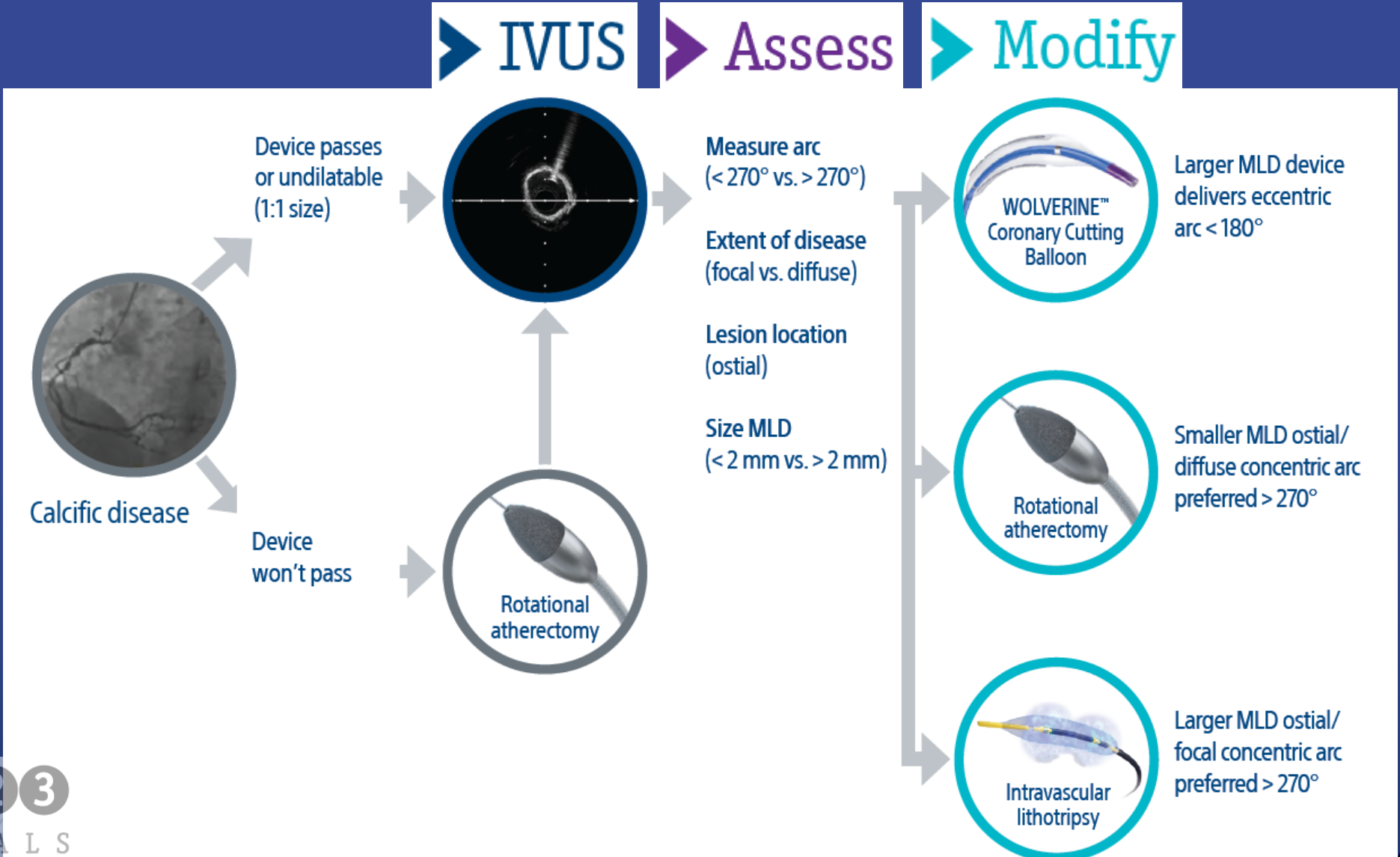

Assess Calcium FIRST with IVUS

Thickness

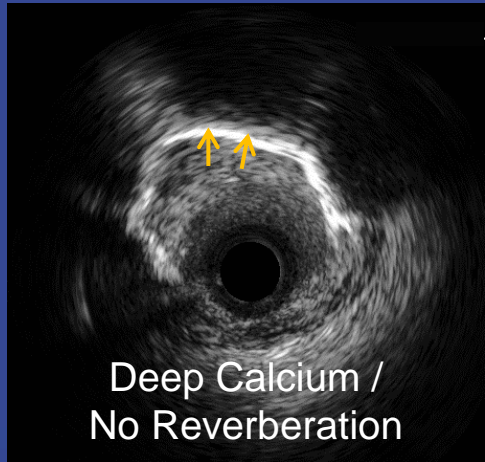

Angle

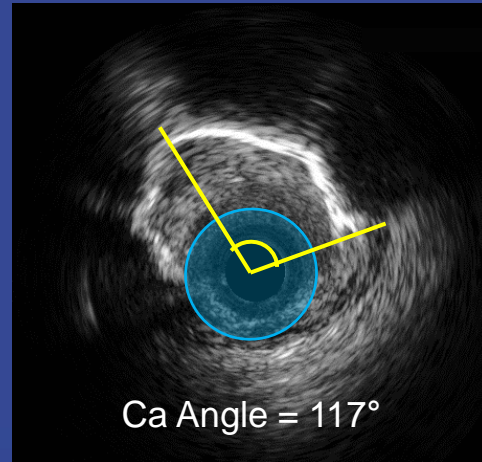

Length

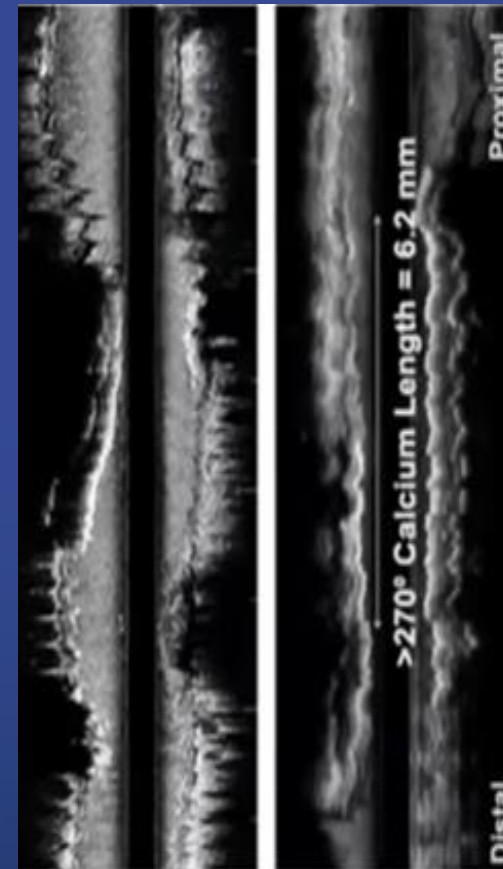

Nodule

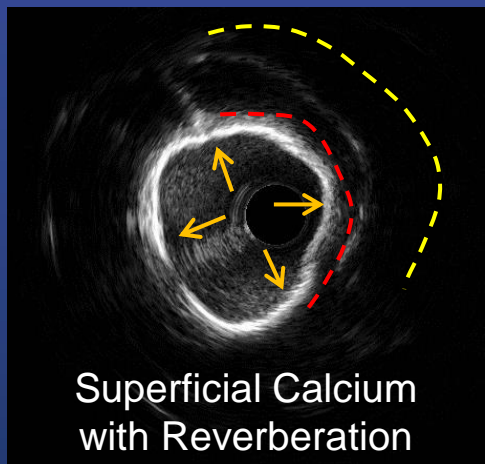
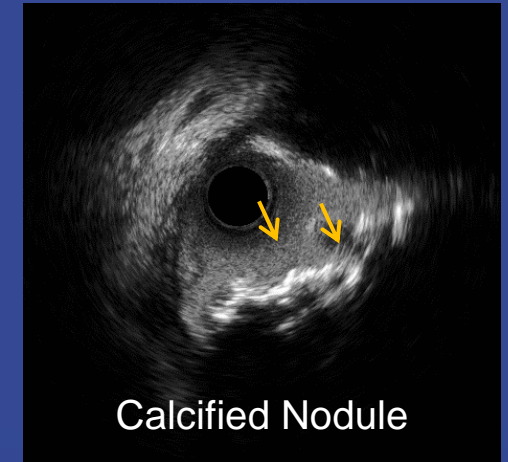

LONGITUDINAL
VIEW

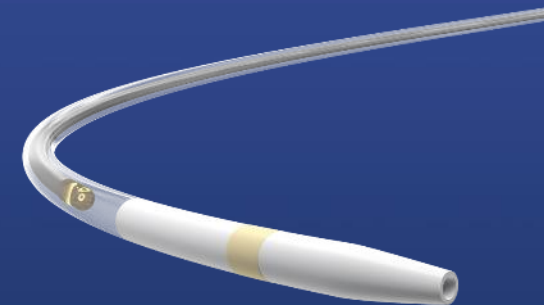

Proven Mechanism of Action

Effective. Safe. Versatile.

Wolverine's innovative design safely and efficiently cracks calcium³

1

Atherotome Amplified Force.¹

The atherotomes anchor into the plaque and amplify pressures generated by the balloon. This creates controlled, longitudinal cracks in the calcium.¹

2

Safely Cracks Calcium.

Due to its unique design, Wolverine can modify calcium at lower pressures than POBA.³ Atherotomes penetrate a small distance into the vessel wall, even in healthy tissue.⁴

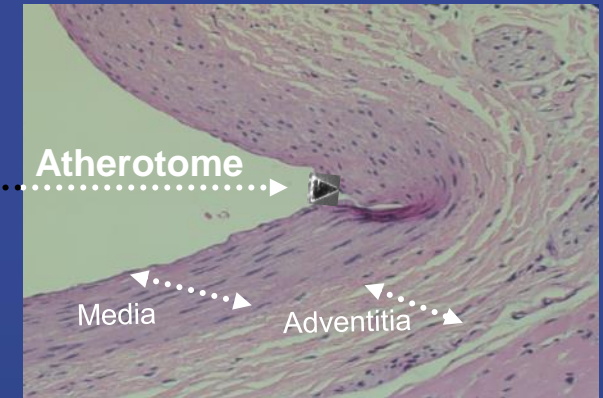
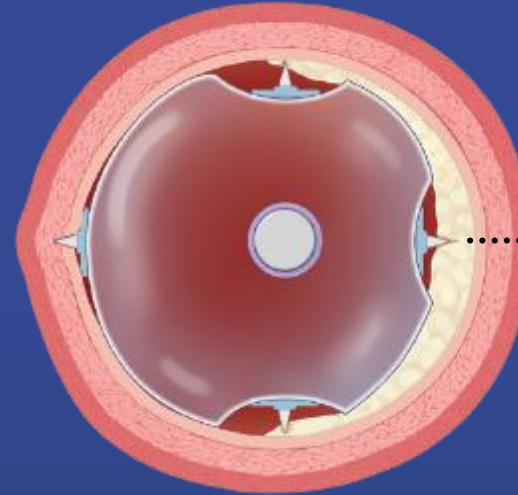

Pre-clinical Swine Coronary artery post Cutting Balloon¹

Atherotome Cutting Height	127 μm
Human LAD Media Thickness ²	320 μm
Human LAD Wall Thickness ²	900 μm

¹ Xiaodong Zhu et al; Circ Rep 2021; 3: 1 – 8 doi: 10.1253/circrep.CR-20-0070. Results of computer models are not predictive of clinical performance. Clinical results may vary.

² Bonan, J InvasivCardiol, 1999; 11: 230

³ Mangieri, A. Cutting Balloon to Optimize Predilatation for Stent Implantation: The COPS Randomized Trial, TCT 2022

⁴ Data on file. Photos taken by Boston Scientific. Results of internal bench studies are not representative of clinical performance. Clinical results may vary.

Treating Calcium with WOLVERINE™

Calcification Model Stress Distributions

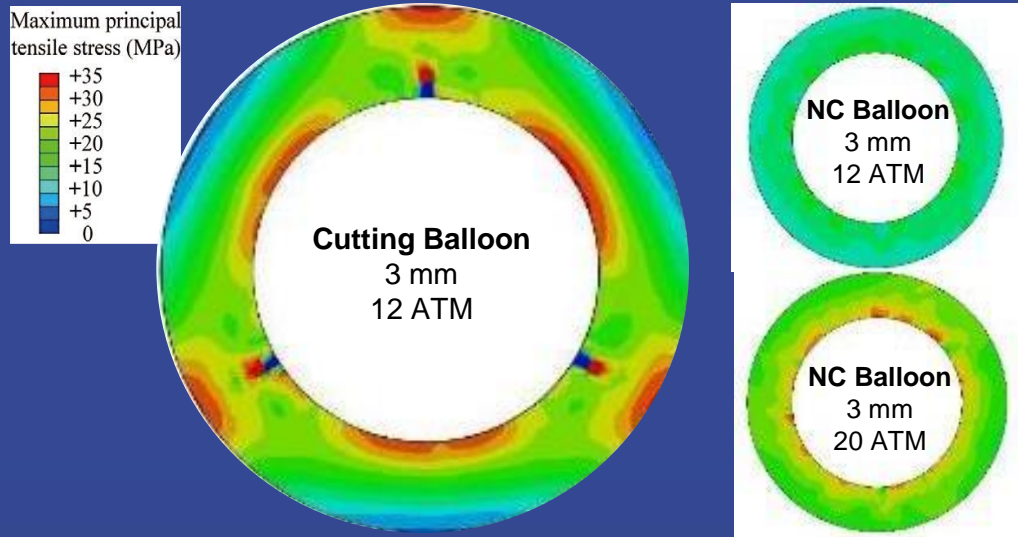

- WOLVERINE™ atherotomes amplified balloon peak tensile strength **3X** vs NC Balloon
- Force is focused at atherotomes for controlled even calcium cracking
- **Balloon dilation force is enhanced** between the anchored atherotomes

Peak Value of Maximum Principle Tensile Stress (MPa)

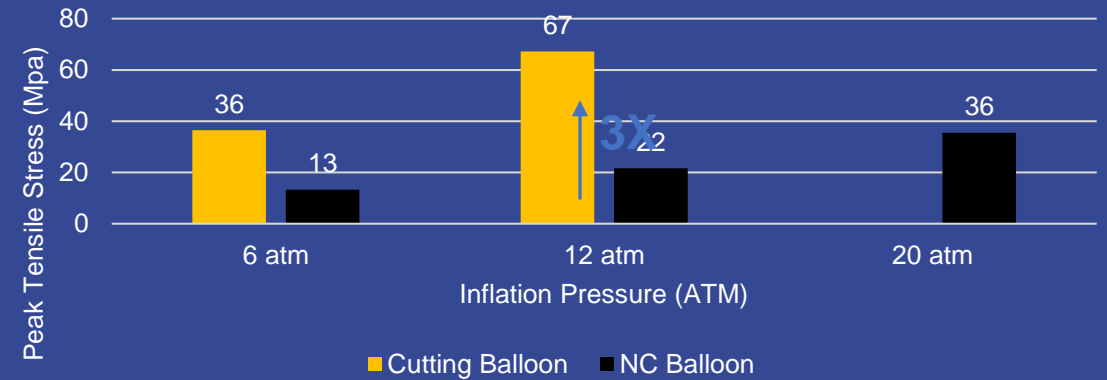

Average Fracture Pressure (ATM) 400 µm 360° Lesion

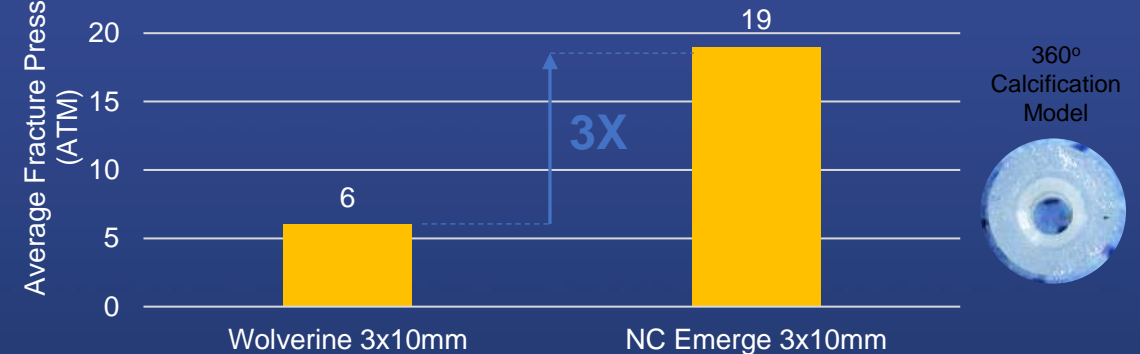

Kiyotaka IWASAKI. Euro PCR 2019; Influences of thickness and circumferential angles of calcification on the capability of fracturing calcification of the cutting balloon: an experimental investigation. Inflated up to 20 ATM until calcification model cracked in 37C water bath. Results of bench models are not predictive of clinical performance. Clinical results may vary.

Demonstrated Efficacy in both Concentric and Eccentric Calcium

BEFORE

AFTER

ECCENTRIC
LESION

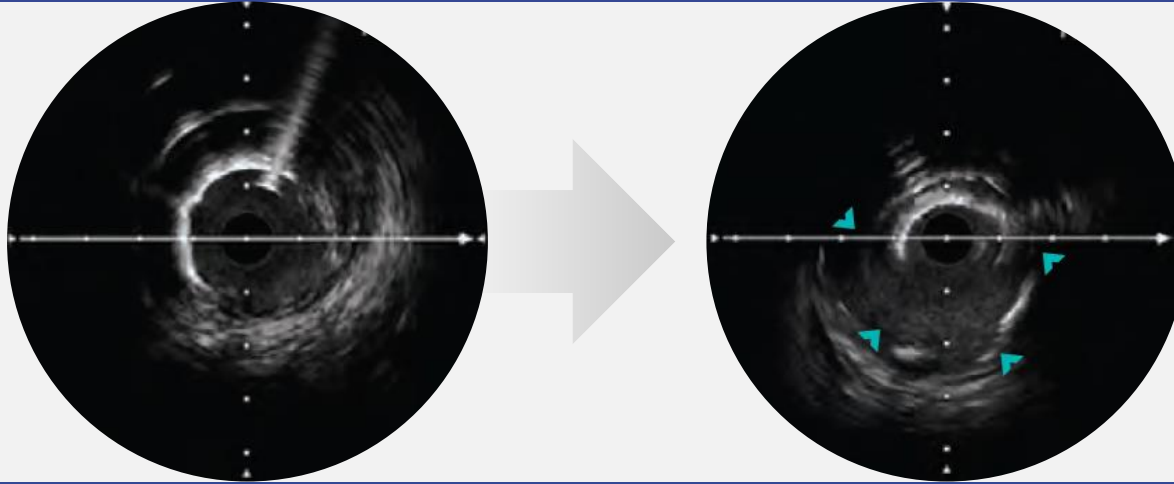

CONCENTRIC
LESION

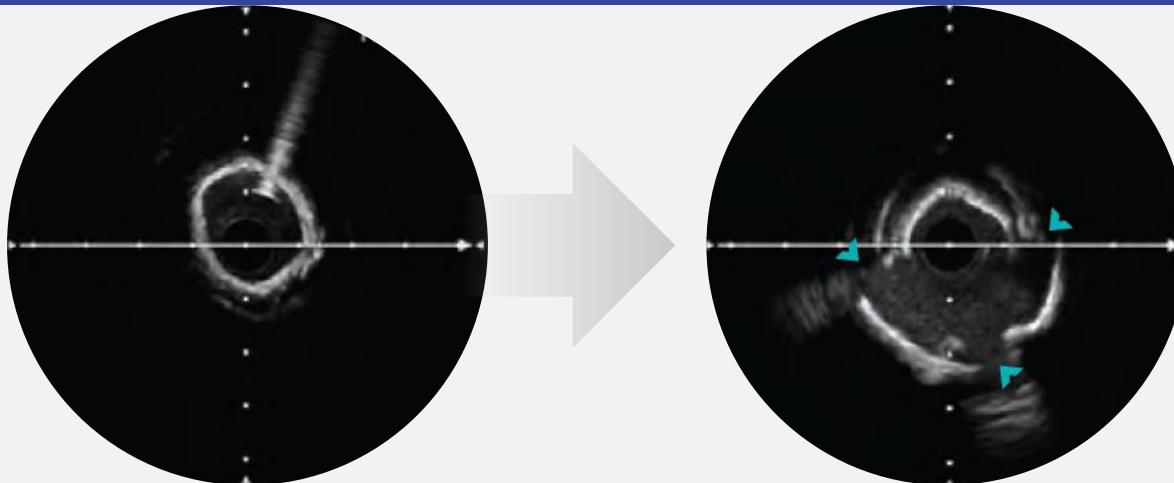

WOLVERINE™ has clinically demonstrated effectiveness in calcium ranging from 0° to 360° with a proven mechanism of action.¹

WOLVERINE™ Cracking Power in Action!

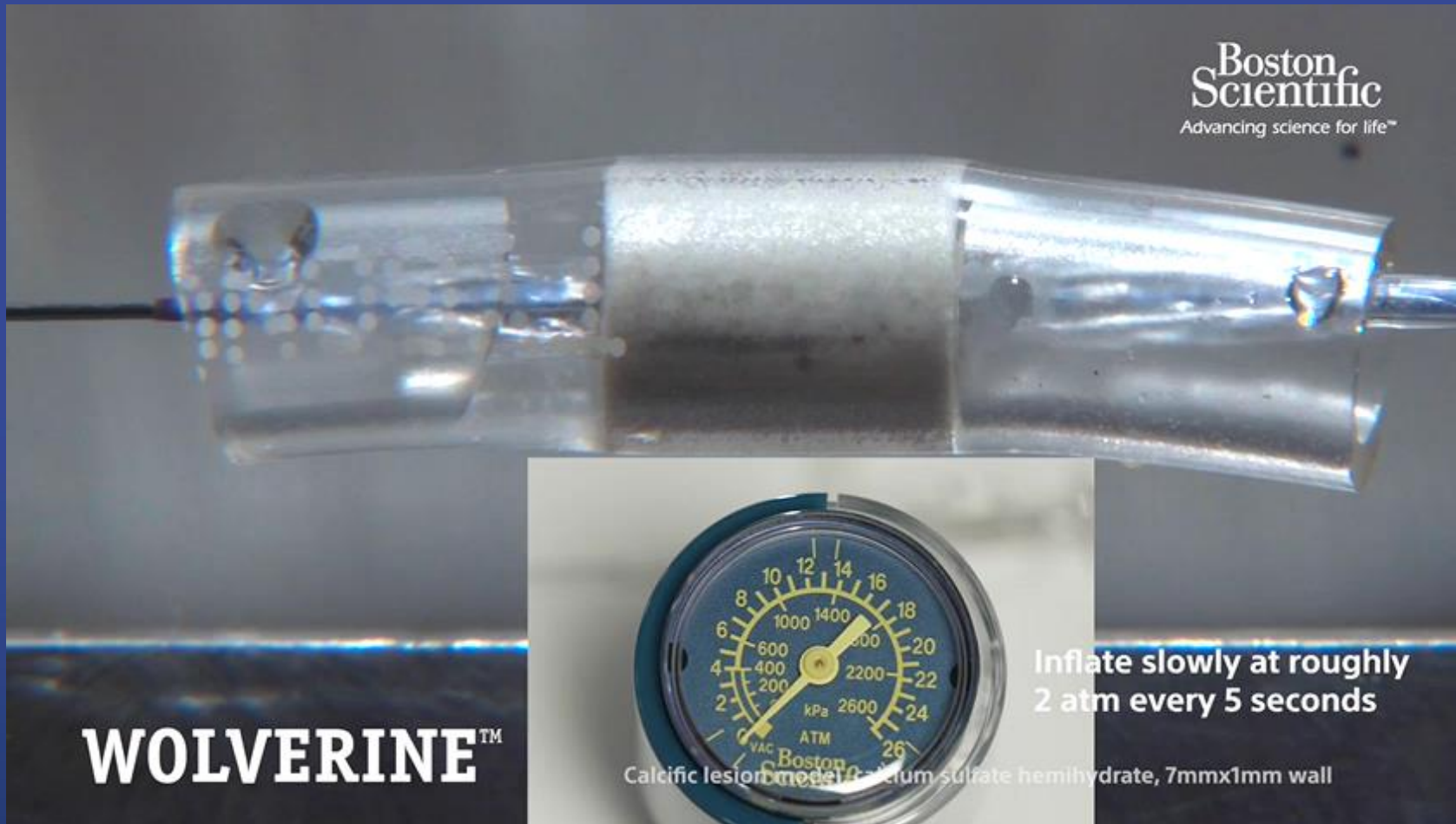

The COPS Trial

Cutting balloon to Optimize Predilatation for Stenting



Primary Investigators

Dr. Antonio Mangieri, Dr. Antonio Columbo

Three hospitals in Italy

Maria Cecilia Hospital, Humanitas Rozzano, Clinica Mediterranea

Study Design

- Prospective, randomized, multicenter open-label trial which enrolled 100 patients with significant calcified lesions evaluated at IVUS

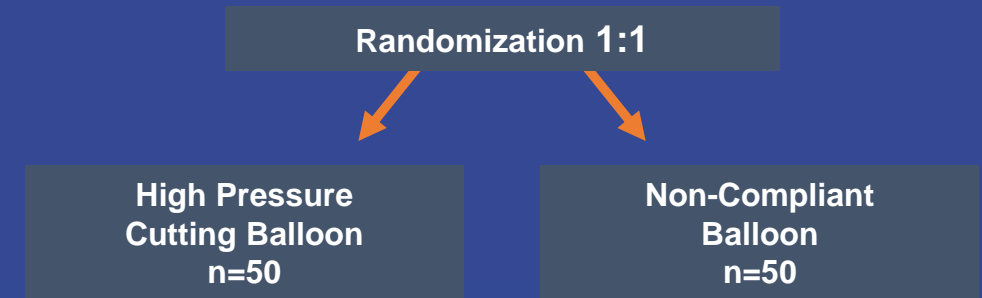

Primary Endpoint

- Minimal Stent Area (MSA) at Calcium Site

Secondary Endpoint

- Eccentricity Index : $(LD \text{ max} - LD \text{ min}) / LD \text{ max}$
- MSA
- Device Failure
- Safety: Procedural Complications & One-Year MACE

The COPS Trial: Results

Study contained a range calcium 100 – 360° and 29.4% avg of deep calcium

	Overall	CB (n=44)	NCB (n=43)	P value
Lesion Type				
Type B1	25 (28.7)	14 (32.5)	11 (25)	
Type B2/C	62 (71.2)	29 (67.4)	33 (75)	
Calcium distribution				0.482
Mixed Calcium	34 (40)	15 (34.8)	19 (45.2)	
Deep Calcium	25 (29.4)	15 (34.8)	10 (23.8)	
Superficial Calcium	26 (30.5)	13 (30.2)	13 (30.9)	
Arch of calcium (degrees)	266±84	274±84	258±85	0.373
Calcium length (mm)	12±6.6	11.9±7.3	12.5±6	0.667
Lesion length (mm)	24.3±9.7	23.5±9.6	25.1±9.8	0.442
Minimal lumen area (mm ²)	3.2±0.9	3.4±1.1	3±0.7	0.02
QCA evaluation				
Reference vessel diameter (mm)	3.4±0.4	3.51±0.3	3.39±0.4	0.112
Percentage of stenosis (%)	81.2±8.1	79.4±7.6	82.7±8.3	0.97

WOLVERINE is clinically proven to provide superior MSA at the calcium site compared to POBA

	CB (n=44)	NCB (n=43)	P value
Final MSA (mm²)	7.1±1.7	6.5±2.1	0.116
Minimal Stent Diameter	2.7±0.4	2.5±0.4	0.064
Maximal Stent Diameter	3.2±0.4	3.1±0.4	0.189
Final MSA at calcium site	8.1±2	7.3±2.1	0.035
Minimal stent diameter at calcium site	2.9±0.7	2.7±0.4	0.016
Maximal stent diameter at calcium site	3.5±0.5	3.3±0.4	0.132
Eccentricity index at calcium site	0.84±0.7	0.8±0.8	0.013

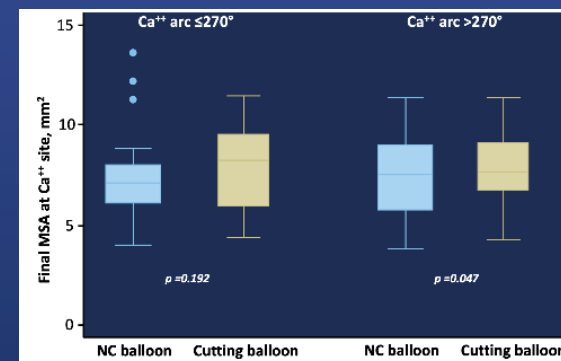

The benefit was magnified in presence of severe calcifications

The COPS Trial: Safety

WOLVERINE™ use in calcium is safe, with no significant differences in procedural complications and 1-year MACE

	Overall	CB (n=44)	NCB (n=43)	P value
Device failure	3 (3.4)	3 (6.8)	0 (0)	0.517
Additional use of rotational atherectomy	1 (1.1)	1 (2.2)	0 (0)	0.79
Ellis type 1 vessel rupture	2 (2.2)	2 (4.4)	0 (0)	0.189
Implantation of a covered stent	1 (1.1)	1 (2.2)	0 (0)	0.65
Final TIMI flow >3	87 (100)	44 (100)	43 (100)	0.854
One year Follow-up				
Deaths	3 (3.4)	1 (1.1)	2 (4.6)	0.342
Cardiac deaths	1 (1.1)	0 (0)	1 (2.3)	0.887
Stroke	0 (0)	0 (0)	0 (0)	0.91
MI	0 (0)	0 (0)	0 (0)	0.96
TLR	3 (3.4)	1 (1.1)	2 (4.6)	0.49

WOLVERINE provided excellent procedural success with limited need for atherectomy (n=1) despite a high rate of severe calcium in the study

WOLVERINE is both a safe and effective option for modifying severely calcified lesions

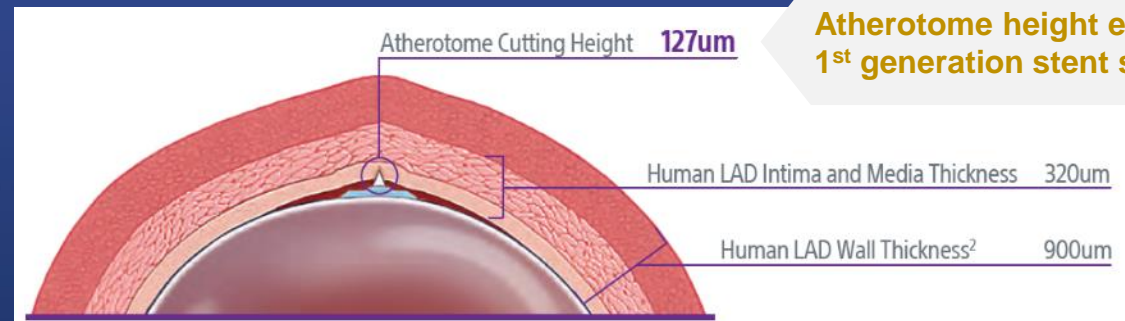

Atherotome height equivalent to 1st generation stent strut thickness

The COPS Trial: Key Learnings

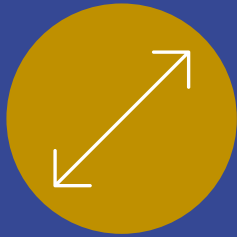

WOLVERINE™ resulted in a **significantly larger minimal stent area** at the calcified segment.



This difference was especially apparent in cases with **severe calcification**.



Stents had significantly **more uniform expansion** after vessel preparation with WOLVERINE.



WOLVERINE is safe for calcium treatment, even when inflated past rated burst pressure.



WOLVERINE[™]
Cutting Balloon[™] Dilatation Device

Competitive Product Comparisons

WOLVERINE vs FLEXTOME

	WOLVERINE™	FLEXTOME™
Manufacturer	Boston Scientific	Boston Scientific
Guide Cath Compatibility	5F, 6F	5F, 6F
Size Matrix: Diameter (mm)	2, 2.25, 2.5, 2.75, 3, 3.25, 3.5, 3.75, 4	2, 2.25, 2.5, 2.75, 3, 3.25, 3.5, 3.75, 4
Size Matrix: Length (mm)	6, 10, 15	6, 10, 15
Pressures (ATM)	NOM: 6 RBP: 12	NOM: 6 RBP: 12
Catheter Length (cm)	143	142
Balloon Compliance	Non-Compliant	Non-Compliant
Balloon Platform	NC EMERGE	NC Quantum MAVERICK
Tip Entry Profile	0.017"	0.020"
Proximal shaft Distal shaft	1.8Fr / 0.59mm 2.6Fr / 0.86mm	2.0Fr / 0.67mm 2.7Fr / 0.90mm
Plaque Mod Method	3 or 4 evenly spaced atherotomes	3 or 4 evenly spaced atherotomes

Atherotome Changes

- Reduce non-functional blade height (portion in the cast pad) to improve profile
- Reduce cast pad height and width to improve profile

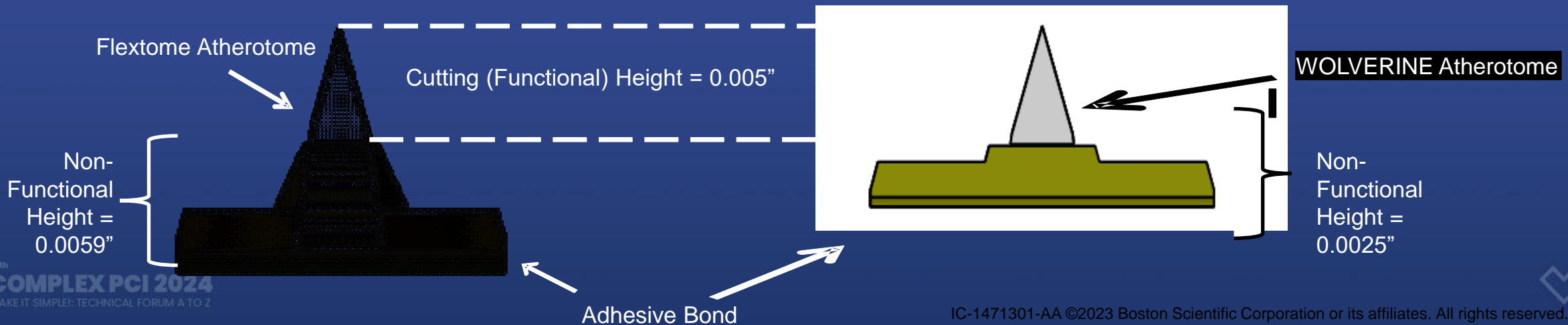
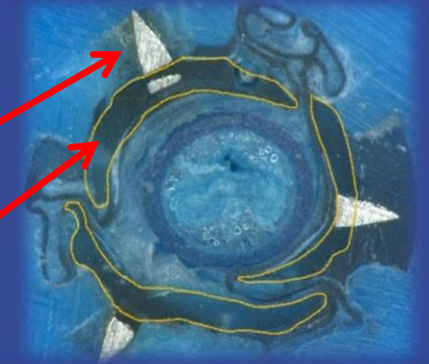
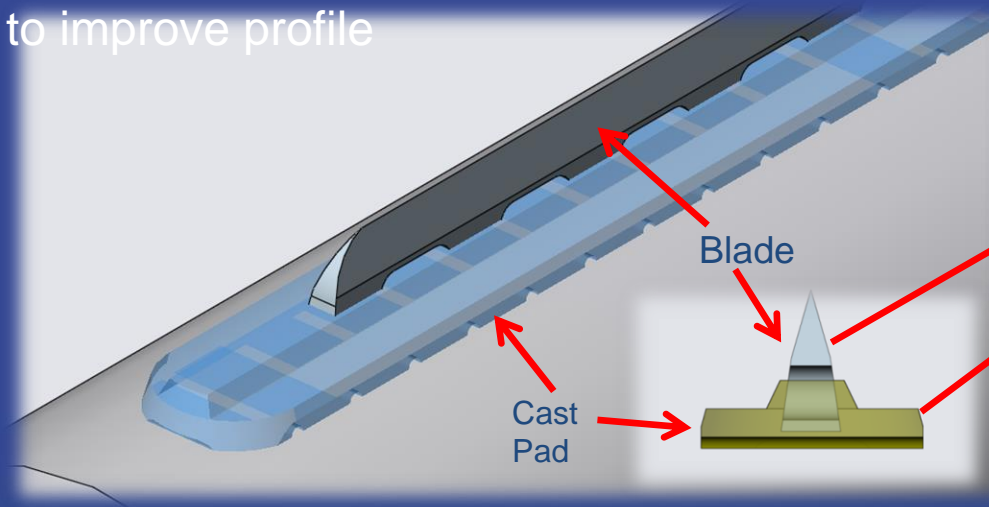

The Atherotome Advantage

WOLVERINE™ Cutting Balloon™ Device Atherotome

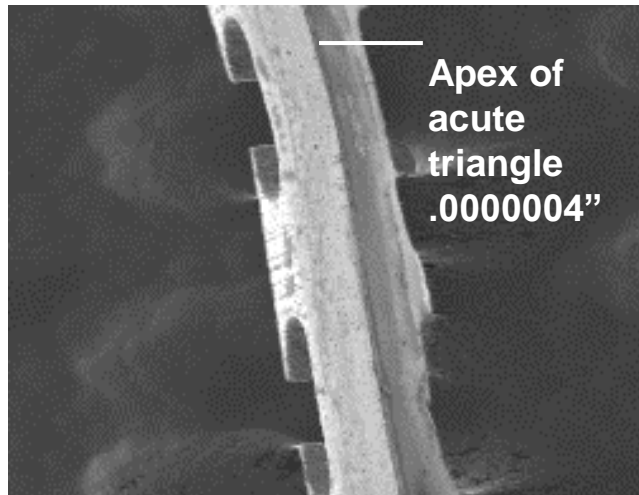

WOLVERINE Atherotome Advantage:

- Amplify balloon inflation pressures in calcium
- Create microsurgical incisions in fibrotic plaque

These two applications help to prepare vessels and limit recoil.

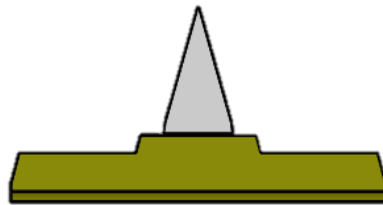

CUTTING BALLOON
CROSS SECTION

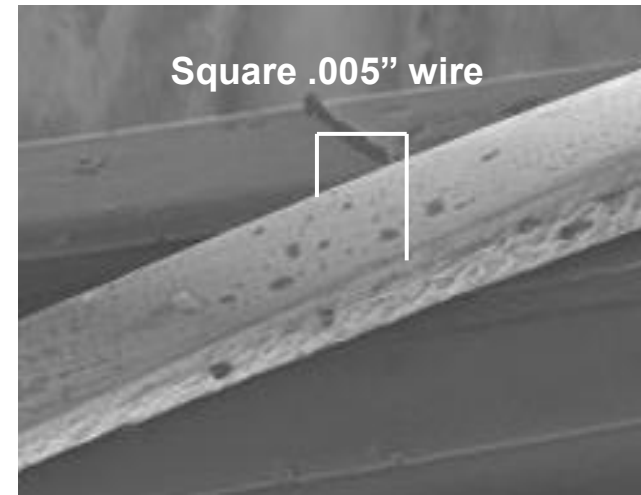

Scoring Balloon Design:

- Flat scoring design provides a blunt force spread over a greater area.
- May explain why published data shows other scoring balloons to not generate as high of acute gain than cutting balloon.

Matsukawa, et al, Cardiovascular Intervention and Therapeutics (2019) 34:325 - 334



SCORING BALLOON
CROSS SECTION

Competitive Specifications

WOLVERINE™ is compatible with smaller guide catheter and offer the broad size matrix to treat according to the type of lesions

	WOLVERINE™	Product A	Product B	Product C
Guide Cath Compatibility	5F, 6F	6F	6F	5F
Size Matrix: Diameter (mm)	2, 2.25, 2.5, 2.75, 3, 3.25, 3.5, 3.75, 4	2, 2.5, 3, 3.5	2, 2.25, 2.5, 2.75, 3, 3.25, 3.5, 4	2, 2.5, 3, 3.5, 4
Size Matrix: Length (mm)	6, 10, 15	6, 10, 15	13	10, 15, 20
Pressures (ATM)	NOM: 6 RBP: 12	NOM: 8 RBP: 16-20	NOM: 6 RBP: 14	NOM: 12 RBP: 20
Catheter Length (cm)	143	137	142	139
Balloon Compliance	Non-Compliant	Semi-Compliant	Semi-Compliant	Non-Compliant
Plaque Mod Method	3 or 4 evenly spaced atherotomes	Wire wrapped balloon	3 scoring elements	Single scoring wire

Clinical Study: Cutting Balloon vs. Scoring Balloon in Severely Calcified Patients

Plaque modification using a cutting balloon is more effective for stenting of heavily calcified lesion than other scoring balloons

Primary Investigator

- Ryuichi Matsukawa, Fukuoka Red Cross Hospital, Fukuoka, Japan

Study Design

- Retrospective analysis of 156 patients treated for calcified coronary artery disease with either Cutting Balloon (n=30), NSE Scoring Balloon (n=39) or Scoreflex Scoring Balloon (n=87) from April 2015 – December 2017

Notable Patient Characteristics

- Patients in all groups had similar characteristics including age, gender, lesion location, Minimum Lumen Diameter, reference vessel diameter and balloon to artery ratio
- However, the cutting balloon patients had a significantly higher rate of severe calcification (83.3%) than NSE (59%) or Scoreflex (44.8%)

Summary of Key Results



30% HIGHER ACUTE GAIN

Despite a significantly higher percentage of severe calcium, cutting balloon resulted in a statistically significant higher acute gain than scoring balloon.

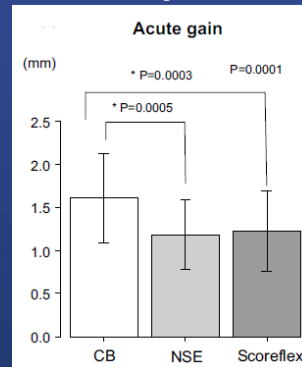

BETTER LUMEN SYMMETRY

Cutting balloon also had a superior effect on stent symmetry index, meaning that the stent lumen was more symmetrical than with scoring balloon.

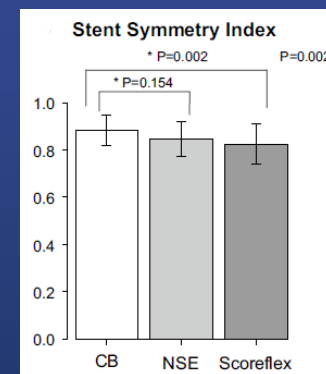

ACHIEVED AT LOWER PRESSURES

This 30% higher acute gain was achieved with cutting balloon despite using a statistically significant lower inflation pressure than scoring balloon.

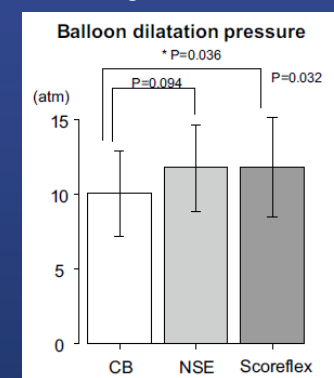



WOLVERINE[™]
Cutting Balloon[™] Dilatation Device

Brief Summary

WOLVERINE™ Brief Summary

PRECAUTIONS

The device should be used only by physicians trained in the performance of PTCA.

If difficulty is experienced during balloon inflation, do not continue; remove the device and do not attempt to use it.

Infusion of any medium through the guidewire lumen other than heparinized saline may compromise device performance.

Do not attempt to reposition a partially inflated balloon.

Do not use a guidewire having a diameter greater than 0.014 in (0.36 mm).

Potential ADVERSE EVENTS

Potential adverse events include, but are not limited to, the following:

- Abrupt closure
- Acute myocardial infarction
- Angina or unstable angina
- Arrhythmias, including ventricular fibrillation
- Arteriovenous fistula
- Cardiac tamponade/pericardial effusion
- Cardiogenic shock
- Cerebrovascular accident/stroke
- Coronary aneurysm
- Coronary artery bypass graft surgery
- Coronary artery spasm
- Coronary vessel dissection, perforation, rupture, or injury, possibly requiring surgical repair or intervention
- Death
- Drug reactions, including allergic reaction to contrast medium
- Embolism
- Hemodynamic compromise
- Hemorrhage or hematoma
- Hypo/hypertension
- Infection
- Minor vessel trauma
- Myocardial ischemia
- Percutaneous re-intervention
- Pseudoaneurysm (at vascular access site)
- Pyrogenic reaction
- Renal failure
- Respiratory insufficiency
- Restenosis of the dilated vessel
- Side branch occlusion
- Slow flow/no reflow
- Thrombosis
- Total occlusion of the coronary artery or bypass graft
- Transient ischemic attack
- Vasovagal reaction
- Ventricular irritability/dysfunction
- Vessel trauma requiring surgical repair or intervention
- Volume overload

WOLVERINE™ Brief Summary

CAUTION: Rx only. Prior to use, please see the complete “Directions for Use” for more information on Indications, Contraindications, Warnings, Precautions, Adverse Events, and Operator’s Instructions.

INTENDED USE / INDICATIONS FOR USE

The Wolverine Cutting Balloon Device is indicated for use in patients with coronary vessel disease who are acceptable candidates for coronary artery bypass graft surgery, should it be urgently needed, for the purpose of improving myocardial perfusion. In addition, the target lesion should possess the following characteristics:

- Discrete (< 15 mm in length), or tubular (10 mm to 20 mm in length)
- Reference vessel diameter (RVD) of 2.00 mm to 4.00 mm
- Readily accessible to the device
- Light to moderate tortuosity of proximal vessel segment
- Nonangulated lesion segment (< 45°)
- Smooth angiographic contour
- Absence of angiographically visible thrombus

CONTRAINDICATIONS

The WOLVERINE Cutting Balloon Device is contraindicated for use in:

Delivery through the side cell of a previously placed stent as the deflated Cutting Balloon could become entangled in the stent.
Coronary artery spasm in the absence of a significant stenosis.

WARNINGS

- Exercise extreme care when treating a lesion distal to a stent. When treating lesions at a bifurcation, the device can be used prior to placing a stent, but should not be taken through the side cell of a stent to treat the side branch of a lesion at a bifurcation.
- The atherotomy process, because of its mechanism of action, may pose a greater risk of perforation than that observed with conventional Percutaneous Transluminal Coronary Angioplasty (PTCA). To reduce the potential for vessel damage, the inflated diameter of the device should approximate a 1.1:1 ratio of the diameter of the vessel just proximal and distal to the stenosis.
- The atherotomy process in patients who are not acceptable candidates for coronary artery bypass surgery requires careful consideration, including possible hemodynamic support during the atherotomy process, as treatment of this patient population carries special risk.
- Balloon pressure should not exceed the rated burst pressure.
- When performing percutaneous atherotomy, the availability of on-site surgical backup should be included as a clinical consideration.